

Preface

Section 1 of this manual goes into some technical detail in describing the System 6300 including the System 6300 processing unit and the TM6000 workstation.

Section 2 provides a step-by-step procedure for installing the System 6300 including unpacking, site selection, installation, and procedures for initial power-up of the system.

No special technical knowledge is necessary to install and power up your system. If you have problems with the definition of words, use the glossary at the back of the manual.

If you have acquired one or more of the peripheral options available with your system, such as a printer, refer to the individual peripheral's Installation and User's Guide for instructions on how to install and hook up these peripheral units to your system.

Section 3 starts the user's guide portion of this manual. The user's guide is intended as a reference for daily operation of your system. Included in the user's guide is Section 3, which identifies all controls, switches, and indicators of your system, and Section 4, which shows you how to maintain and care for your system.

Appendix A of this manual has the specifications for both the processing unit and the TM6000 workstation. Appendix B identifies all the connectors for the processing unit and the TM6000 workstation for quick reference.

RESTRICTED RIGHTS LEGEND

Use, duplication, or disclosure by the Government is subject to restrictions as set forth in paragraph (b) (3) (B) of the Rights in Technical Data and Computer Software clause in DAR 7-104.9 (a).

Four-Phase Systems, Inc.
10700 North De Anza Boulevard
Cupertino, California 95014



Contents

Section 1	Introduction
Section 2	Installation and Powering-Up
Section 3	Getting to Know Your System's Operating Mechanisms
Section 4	Maintenance and Care
Appendix A	The Processing Unit and TM6000 Workstation Specifications
Appendix B	The Processing Unit and TM6000 Connectors
Glossary	



Section 1

Introduction

General Description of the System 6300, 1-1
System 6300 Processing Unit Description, 1-1
TM6000 Workstation Description, 1-4

Illustrations

- 1-1 System 6300 and Printers, 1-2
- 1-2 System 6300 Disc Drives, Connectors, Status Indicators, and the RESET Switch, 1-3
- 1-3 TM6000 Workstation Components and Cables, 1-5

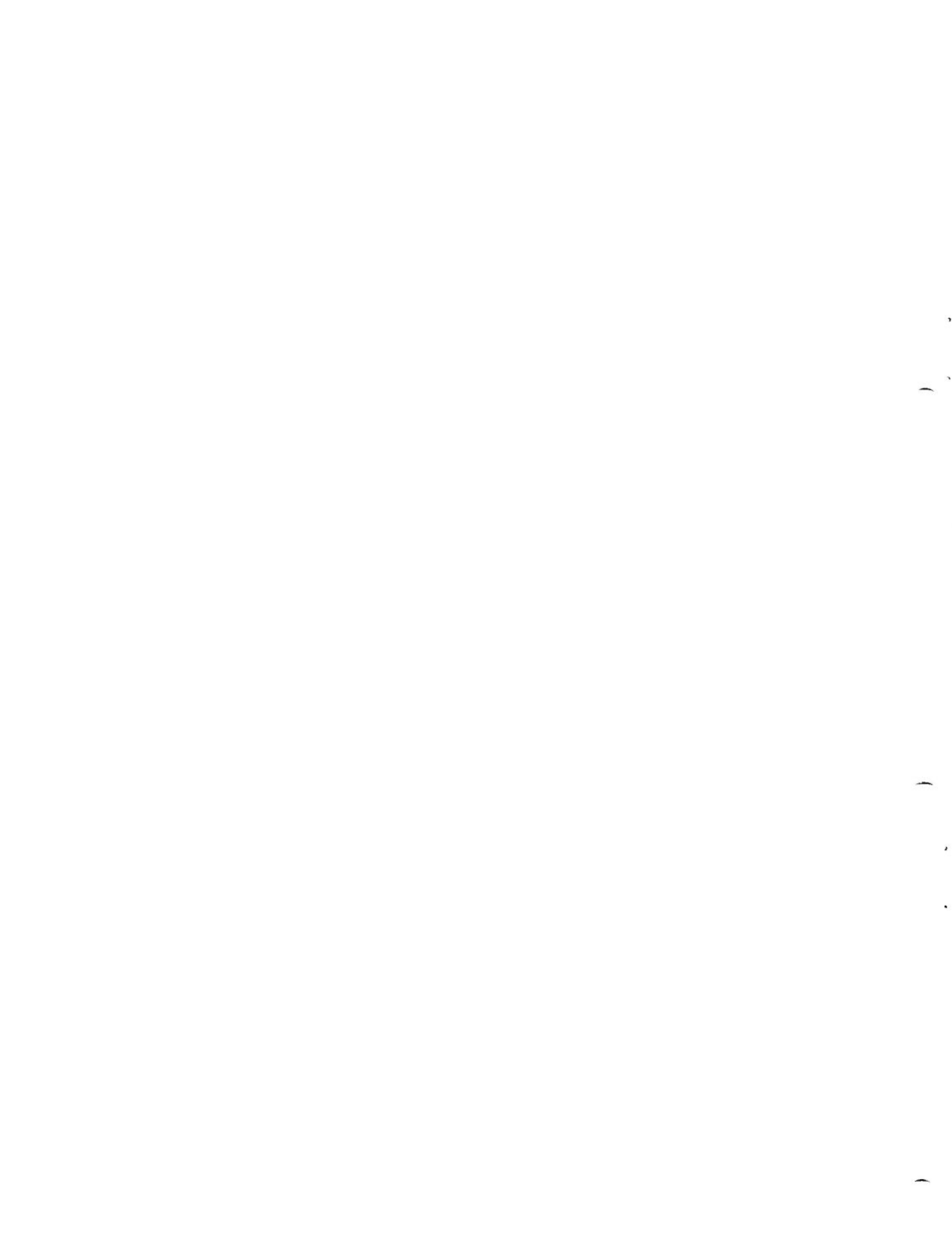

Congratulations, you have just received your System 6300 computer system. The System 6300 is simple to install, simple to get started, and easy to operate.

To get your System 6300 computer system started and ready to operate, you must do the following:

- Get acquainted with the system by reading this introduction to the System 6300.
- Pick an appropriate site for your computer system.
- Unpack the processing unit, the TM6000 workstation, the cables, and memory expansion boards if you have acquired any.
- Install and plug your system into a source of electric power.
- Do the initial power-up of your system.
- Load your software and bring up your system according to the instructions in your *System 6300 Software Installation Guide*.

GENERAL DESCRIPTION OF THE SYSTEM 6300

The basic System 6300 is composed of the processing unit, which has a fixed and a floppy disc drive to store information; a TM6000 workstation, which includes a video display unit, a keyboard, and a power module; the various peripheral options, like printers; and the cabling necessary to connect the processing unit, the TM6000 workstation, and the peripherals together.

Figure 1-1. shows the processing unit hooked up to one TM6000 workstation, one matrix printer, and one character printer. For information on installation, operation, and maintenance of the peripheral or peripherals you acquired with your System 6300, look at each peripheral's Installation and User's Guide.

THE SYSTEM 6300 PROCESSING UNIT DESCRIPTION

The System 6300 processing unit uses the powerful MC68010 microprocessor. The standard system comes with 1 megabyte of memory that you can expand to 2 megabytes of memory (enough memory for 2 million typed characters), and can support up to eight terminal workstations.

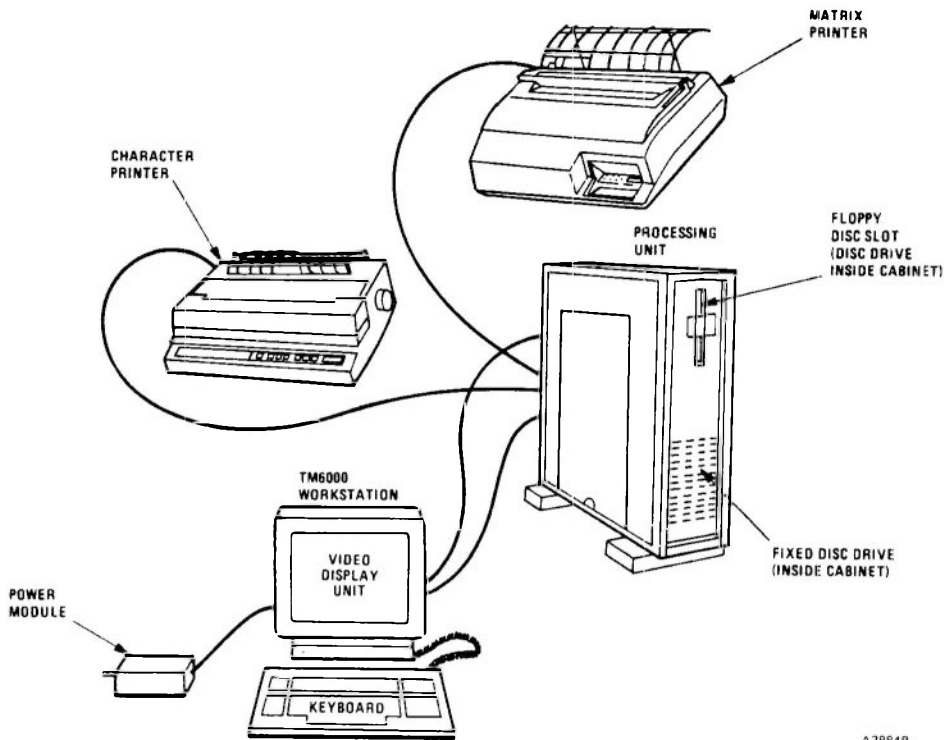

A3884B

Figure 1-1. System 6300 and Printers

As mentioned previously, the processing unit has both a fixed disc drive and a floppy disc drive to store programs and data information. The floppy disc drive allows you to enter or remove programs or data from the processing unit by entering and removing floppy diskettes.

The System 6300 processing unit has the following connectors on the rear of the processing unit: the cluster connector to connect terminals; the parallel printer connector to connect parallel printers; channel 1 to connect printers, terminals, or communication devices; and channel 0 to connect the first terminal to your processing unit with an RS-232 Cross cable.

The rear of the processing unit also has status indicators that indicate the status of the processing unit as it goes through its different functions; and it has the RESET switch that restarts the processing unit if it has been shut down.

Figure 1-2 points out the system's disc drives, connectors, status indicators, and the RESET switch:

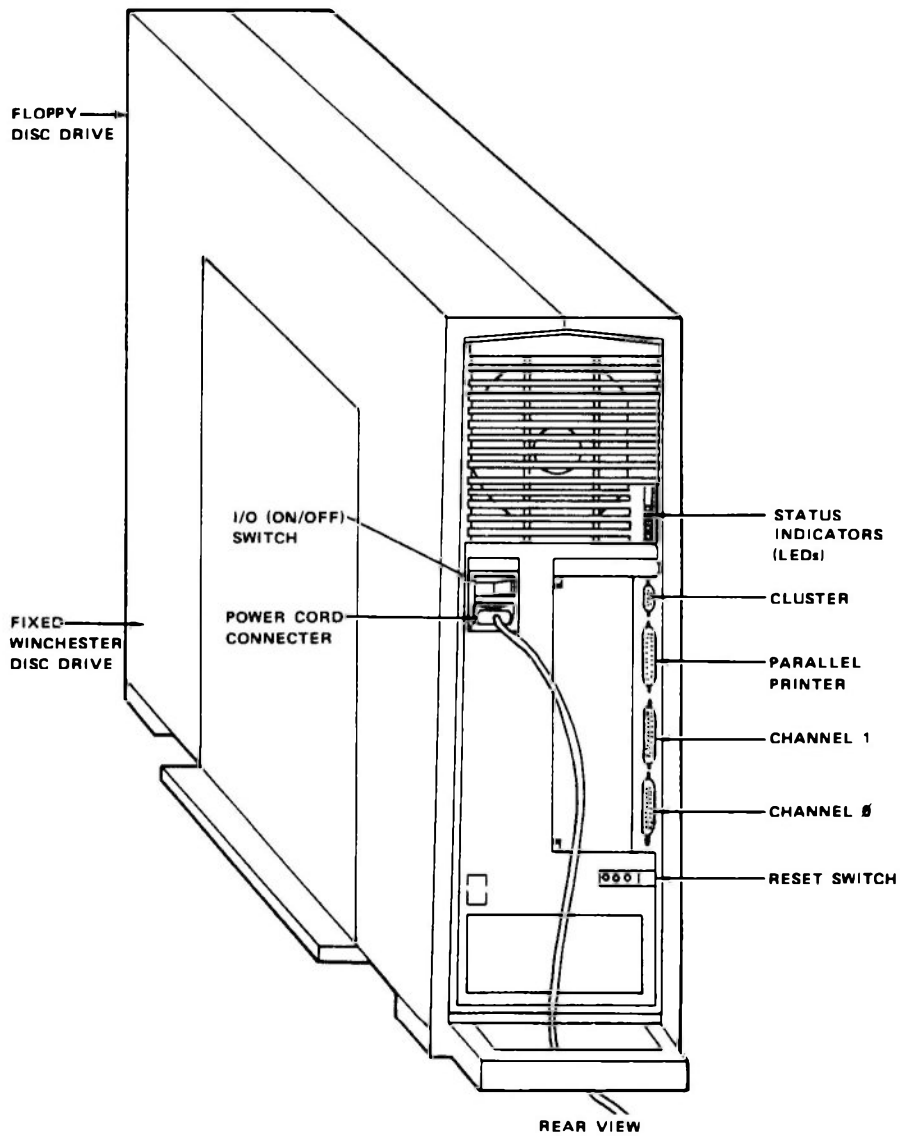

A4256A

Figure 1-2. The System 6300 Disc Drives, Connectors, Status Indicators, and the RESET Switch

For the dimensions, power requirements, and environmental specifications of the System 6300 processing unit, see Appendix A in this manual.

THE TM6000 WORKSTATION DESCRIPTION

The TM6000 workstation is an intelligent terminal. This means that the TM6000 can perform certain functions with its own software instead of relying on the processing unit's software.

The TM6000 video display unit displays up to 26 lines of 80 characters per line. The TM6000 offers eight possible foreign language font choices, business graphics capabilities, and a video display unit with a tilt-and-swivel action. Also, if you acquire the proper software from Four-Phase Systems, the TM6000 can produce split screens that can be scrolled independently of each other.

The TM6000 workstation, as shown in Figure 1-3, consists of the following components:

- The video display unit with its base assembly
- A keyboard and coiled keyboard cable
- The power module with one short power cord, one long power cord, and one flat power cable
- The RS-232 Cross cable and RS-422 cable

The RS-422, and the RS-232 Cross cables that connect the TM6000 workstation to the processing unit are considered part of the TM6000 workstation for our description purposes.

NOTE: The RS-232 Cross cable is used only to connect the first TM6000 workstation to the processing unit.

For the dimensions, power requirements, and environmental specifications for the TM6000 workstation, see Appendix A in this manual.

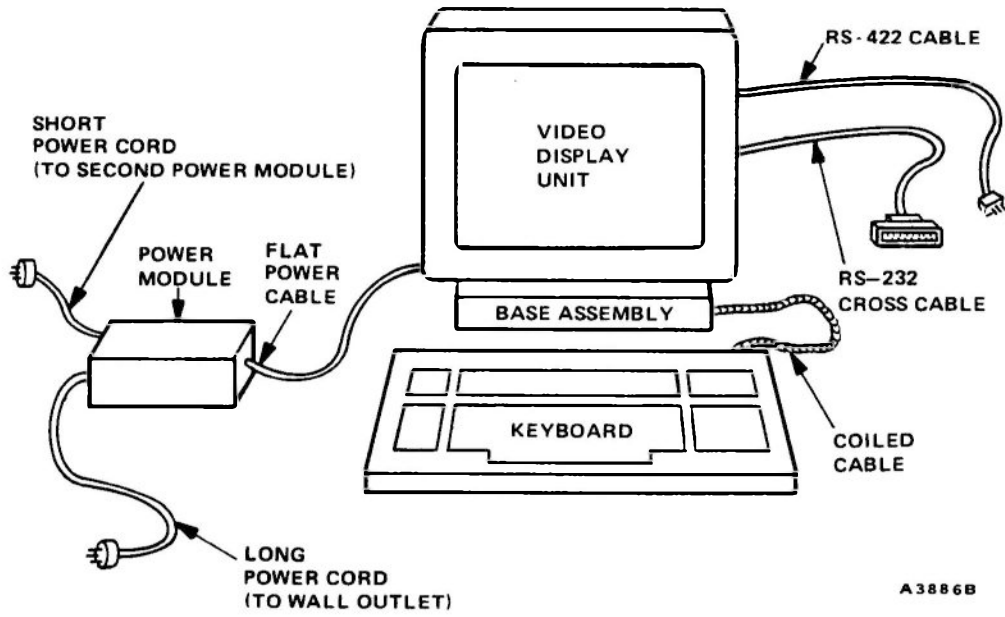
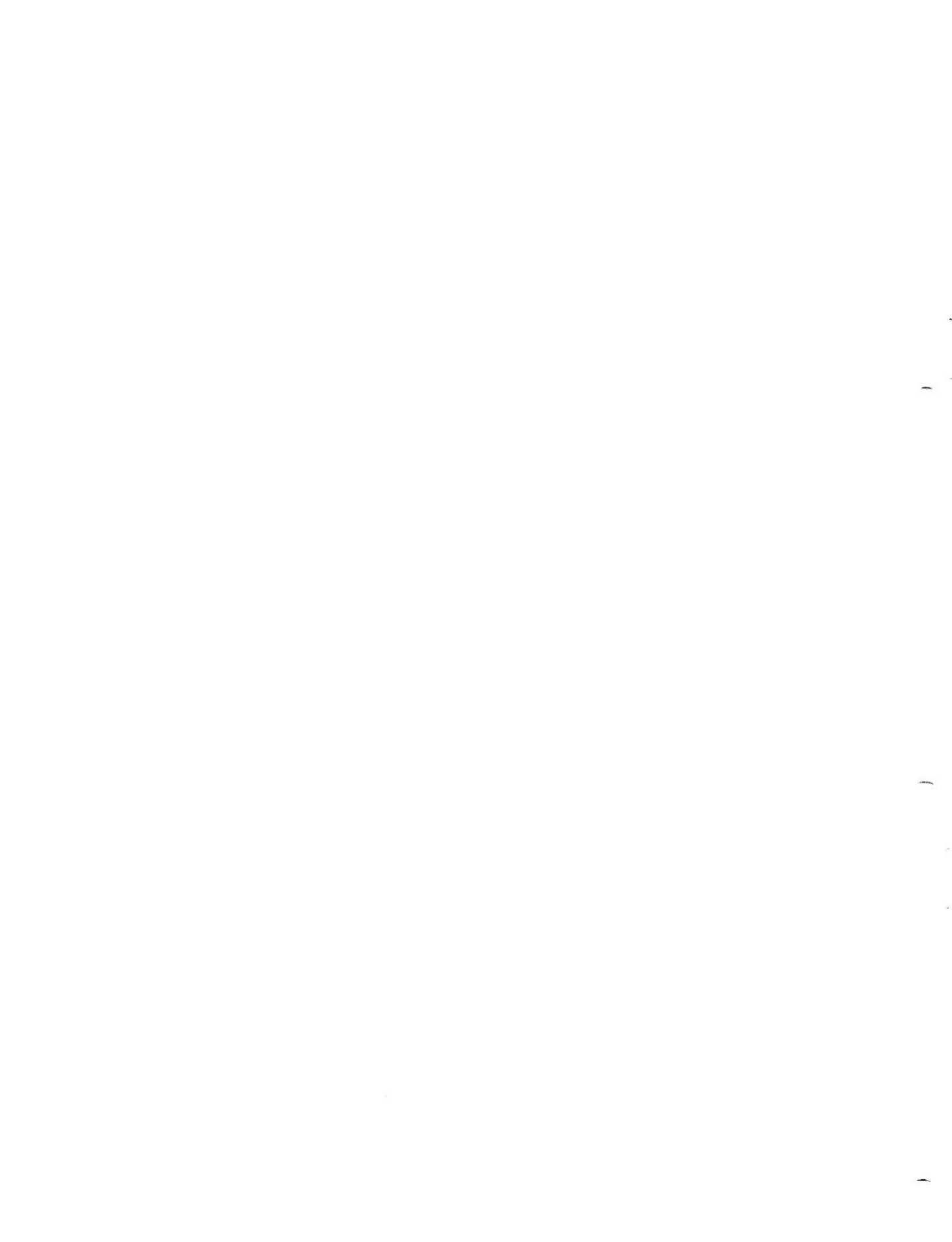

Figure 1-3. TM6000 Workstation Components and Cables



Section 2

Installation and Powering-Up

Site Selection, 2-1

Unpacking the Processing Unit, 2-2

Unpacking the TM6000 Workstation, 2-6

Unpacking the Cables, 2-11

Unpacking the Memory Expansion Board, 2-12

Installing and Powering Up the System, 2-13

 Installing a Memory Expansion Board, 2-13

 Installing and Powering Up the System 6300, 2-26

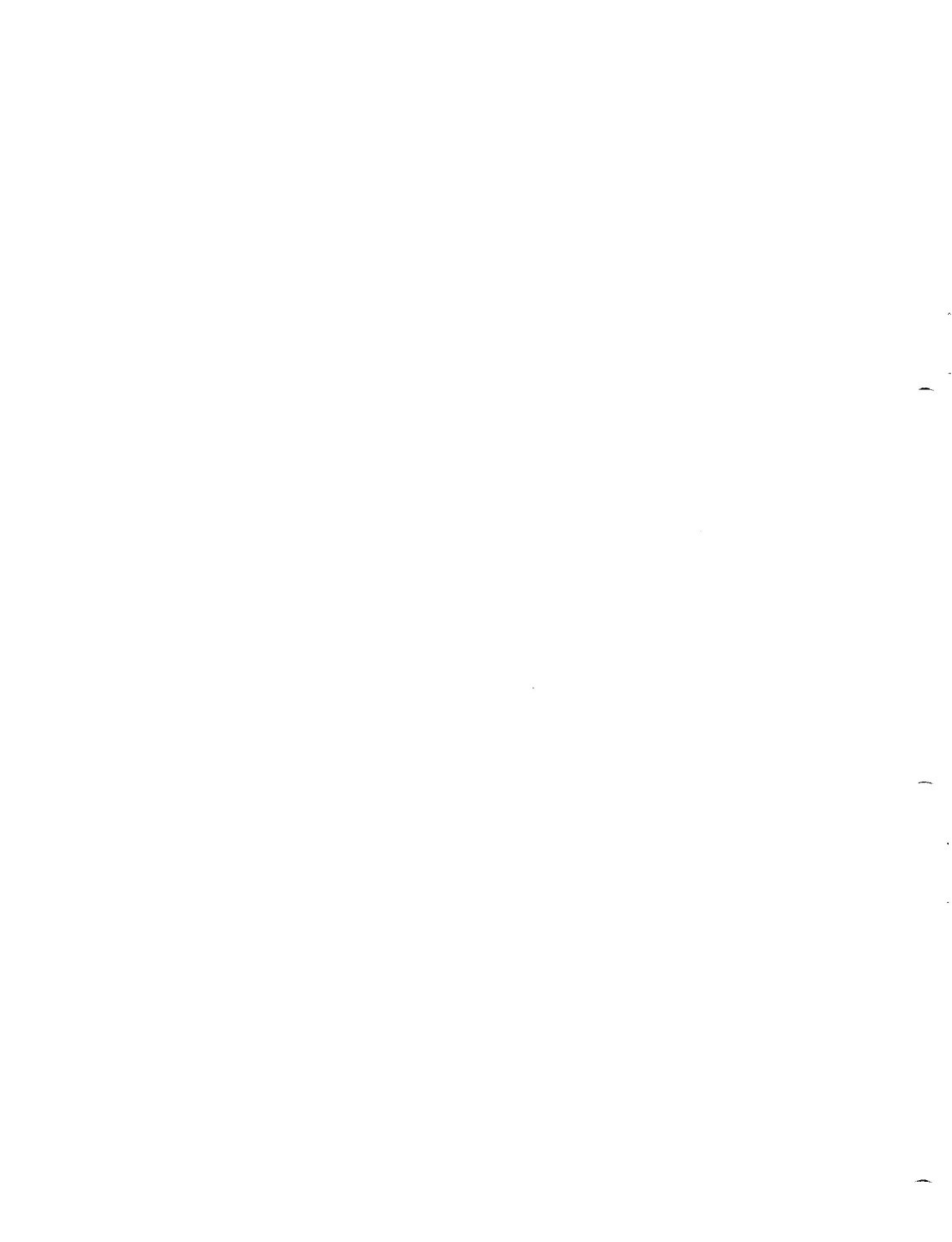

This section covers all that is involved in installing and powering up the system. Included are all the necessary preparations to install and power up the System 6300 including selecting an appropriate site for the system, unpacking the processing unit, unpacking the TM6000 workstation, and unpacking the cables.

If you have acquired one of the printers or other peripheral options available with the System 6300, see that peripheral's Installation and User's Guide for unpacking and installation instructions.

SITE SELECTION

When installing the processing unit be aware of the following site requirements:

- **Cable Access:** Place the processing unit in a place where the cables can be reached. Also, make sure that the processing unit is placed where the cables can reach all the various peripherals.
- **Access to Switches:** Position your unit so the various switches located in the rear can be reached without moving the unit.
- **Ability to Open Cabinet:** Leave three feet of space to the left of the processing unit as you face the front of it. You need this space so that the Field Engineer can open up the unit if the various internal parts need to be checked.
- **Proper Ventilation:** The processing unit must be positioned in a spot where there is no obstruction at the front and rear of the unit's ventilation grilles. Also make sure that there is adequate air conditioning in the room where you place the unit to keep it within the proper operating temperature range. Remember that, in general, the cooler a unit operates, the more trouble-free is its life. See Table A-3 in Appendix A of this manual for environmental specifications.
- **Electrical Outlets:** The unit must be close to enough three-pronged grounded power outlets so the processing unit and all the peripherals can be plugged in. Power outlets must conform to electrical code requirements for your location. See Table A-2 in Appendix A of this manual for processing unit power requirements. See the individual peripheral installation manuals for the power requirements for those peripherals.

- **Solid Floor:** The unit must be placed on a floor with a solid foundation that is free from abrupt movement.

UNPACKING THE PROCESSING UNIT

The processing unit comes in a large box cinched with two bands. To unpack the processing unit perform the following procedure:

- 1 Make sure the box is upright. The oblong slot in the box should be at the bottom as shown in the following figure.

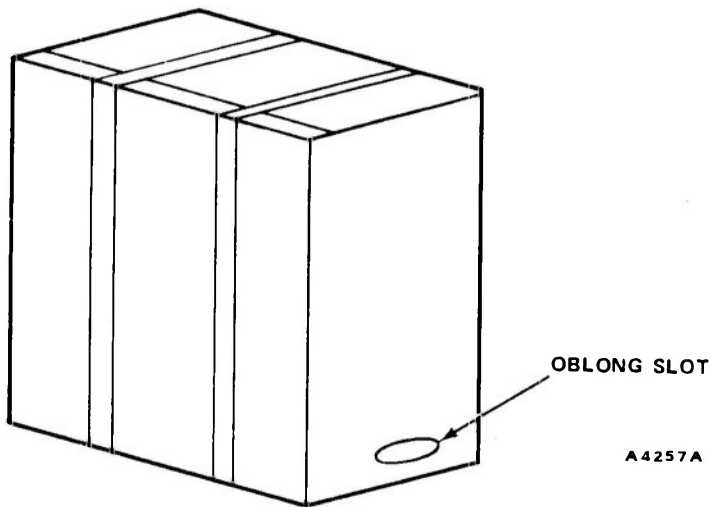

The Packed Processing Unit

- 2 Cut and remove the two bands cinching the box. See the following figure.

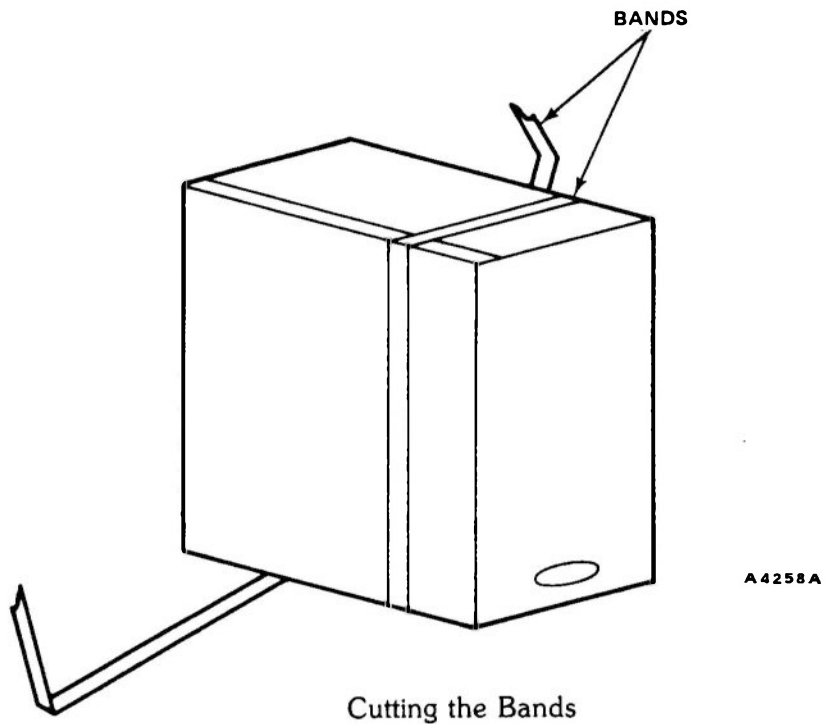

- 3 Fold back the box lids and remove the top piece of foam as shown in the following figure. Also, pull out the processing unit's power cord from inside the box.

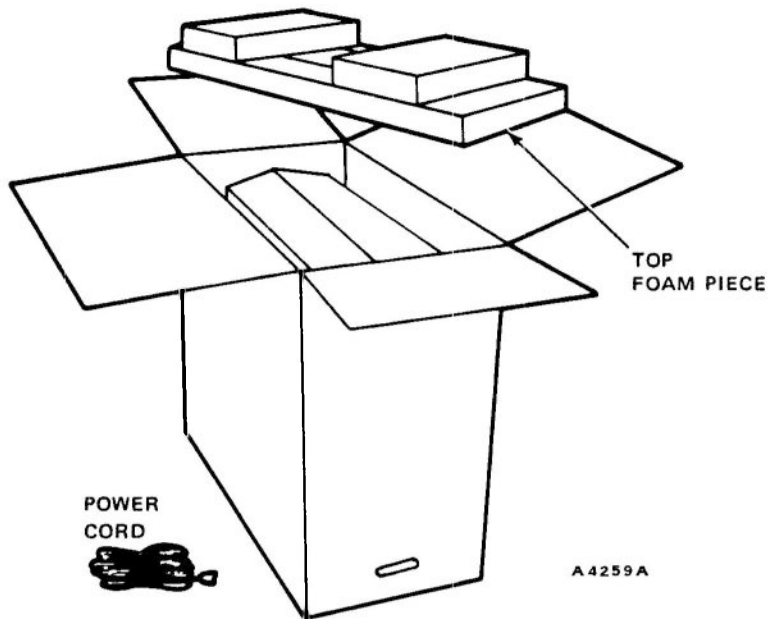

Unpacking the Processing Unit

- 4 Remove the box by lifting it upwards carefully, leaving the processing unit exposed and sitting in the bottom foamed box called the "carrier." See the following figure.

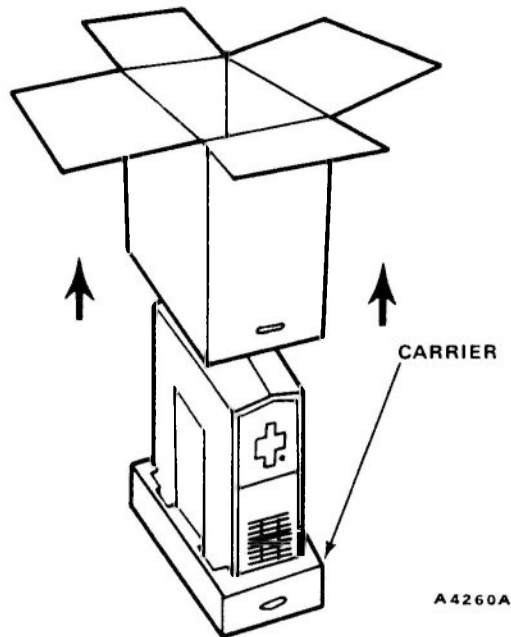

The Processing Unit in the Carrier

- 5 You need two people to lift the processing unit out of the carrier carefully. One person grips the front of the processing unit and the other person grips the rear. Each person should grip the top of the unit with one hand and underside of the unit with the other hand then lift carefully and place the unit on the floor. Do not use the cable guide as a handle to lift the processing unit out of the carrier. See the following figure.

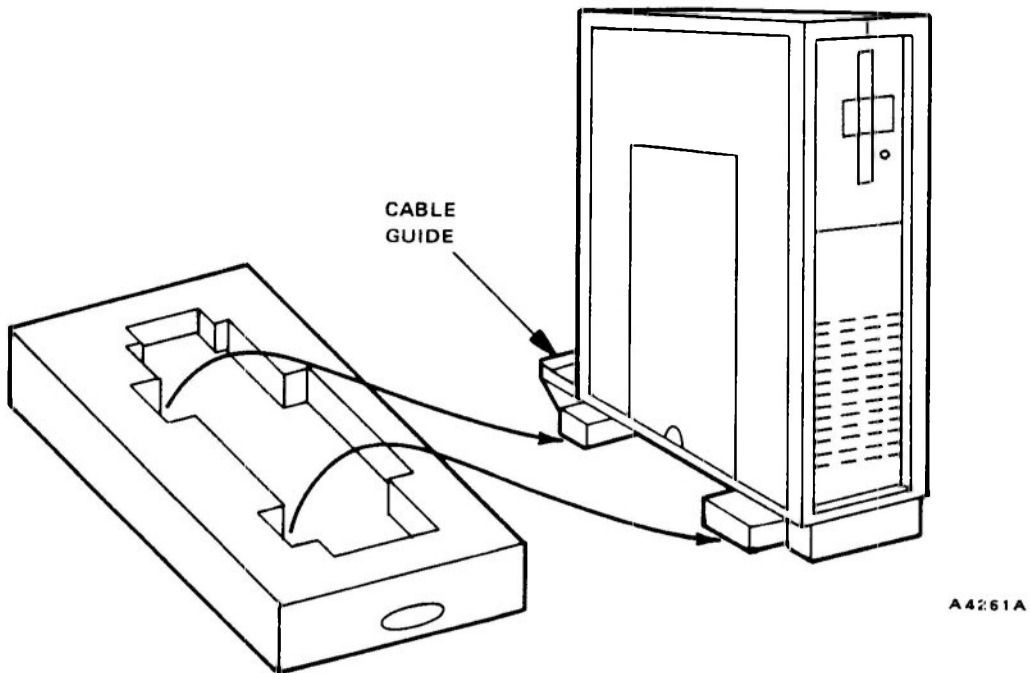

Lifting the Processing Unit Out of the Carrier

- 6 Save the carrier, the box, and the foam pieces for future moving or shipping.

UNPACKING THE TM6000 WORKSTATION

The TM6000 workstation comes in a large box. Inside this large box is a long power cord and three smaller boxes.

The largest of these three boxes is the video display box, which contains the video display unit's screen and base. The long narrow box is the keyboard box, which contains the keyboard and a coiled cable. The smallest box is the power module box, which contains the power module, a short power cord, and a long, flat power cable. These boxes are labeled.

The following figure shows what component pieces you should have in the TM6000 workstation box.

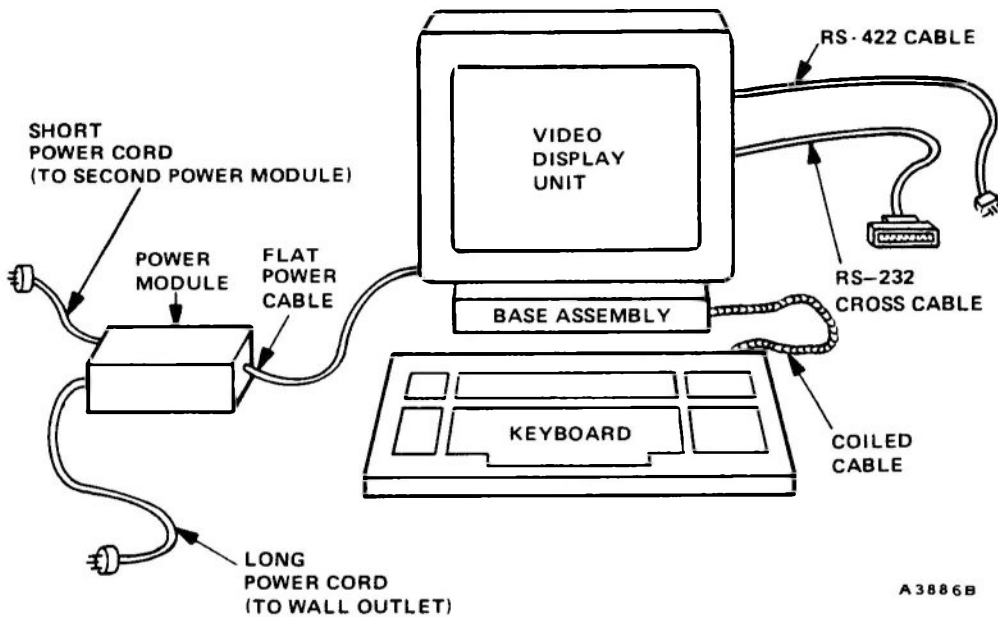

The TM6000 Workstation Components

To unpack the TM6000 workstation:

- 1 Make sure the box is upright. The figures outside the box should be right-side up. See the following figure.

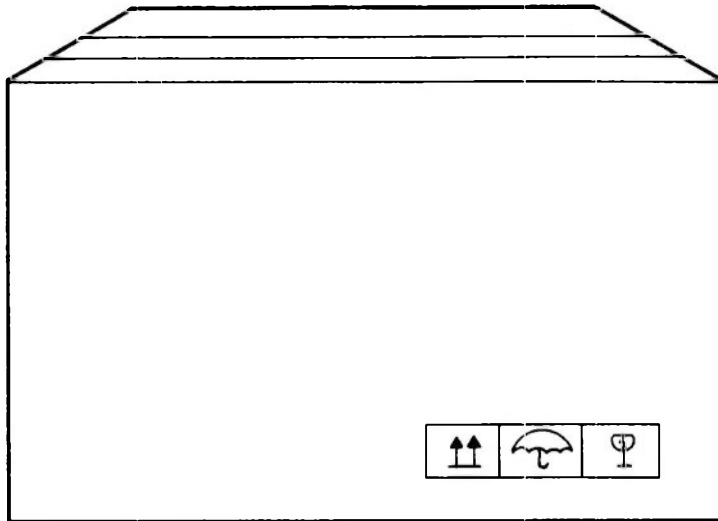

A4262A

The Packed TM6000 Workstation

- 2 Open the top flaps of the TM6000 box; and gently lower the TM6000 box on its side and pull out the three boxes and the long power cord you find inside. See the following figure.

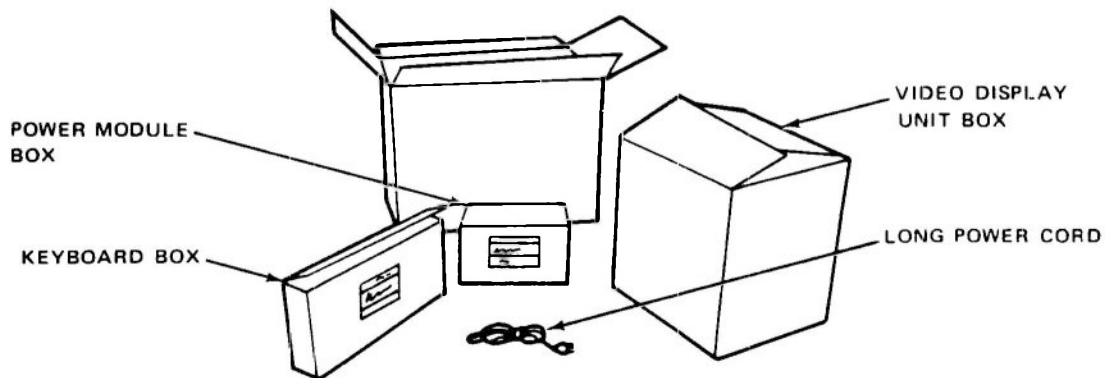

A4263A

Unpacking the TM6000 Box

- 3 Open the video display box and you will find the video display screen and its base suspended in a piece of styrofoam. Lift out the screen and base carefully to avoid damage. See the following figure.

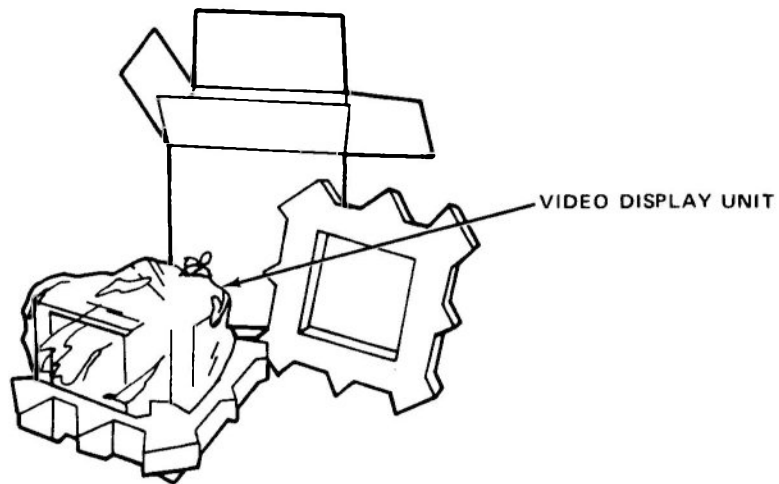

A 4264A

Unpacking the Video Display Box

- 4 Open the keyboard box and lift out the keyboard and the coiled cable found inside. See the following figure.

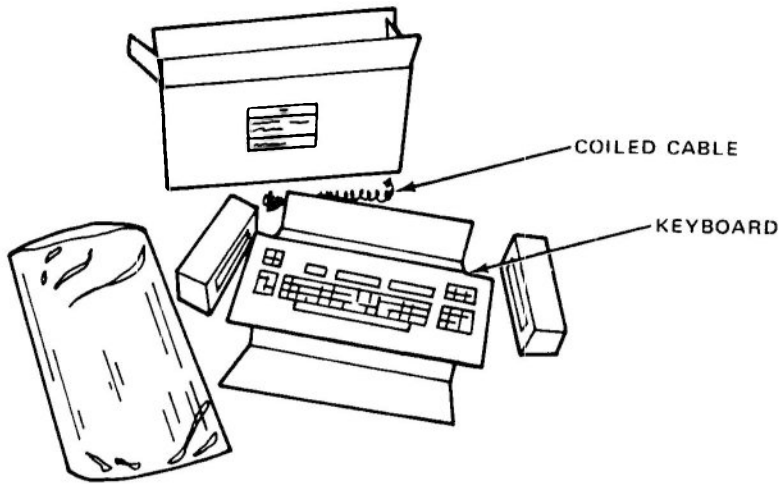

A4265A

Unpacking the Keyboard Box

- 5 Open the power module box and remove the power module. There is also a short power cord inside this box. The power module box also contains a long, flat, thin power cable. See the following figure.

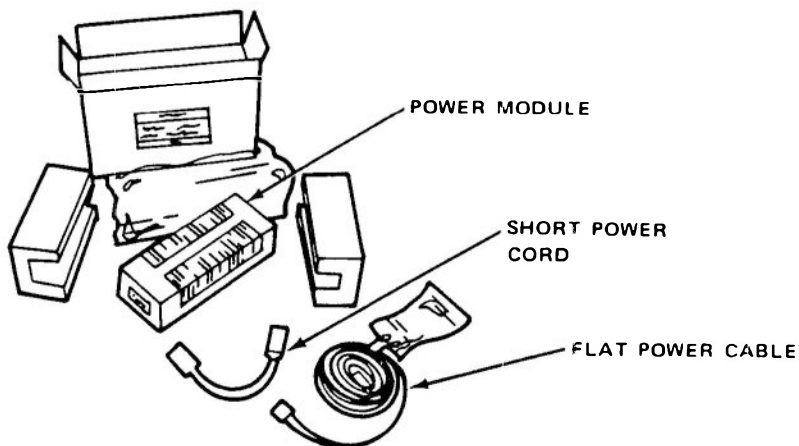

A4266A

Unpacking the Power Module Box

- 6 After you have removed all the components from the boxes, make sure to save all the boxes and foam pieces for future movement or shipment of the workstation.

UNPACKING THE CABLES

The RS-232 Cross and RS-422 cables come in a box separate from both the processing unit and the TM6000 workstation.

The RS-232 Cross cable is the cable with the larger plugs. The RS-422 cable is the cable with the smaller plugs.

You will get one RS-422 cable with each TM6000 workstation so that you can connect all the terminals together.

In the cables' box you will also find a terminator plug. The terminator plug is inserted into the open connector in the last terminal when you have a series of TM6000 workstations connected to each other. If you have only one terminal, the terminator plug is inserted into the open cluster connector in that terminal. The following figure illustrates what you should get in the cables box.

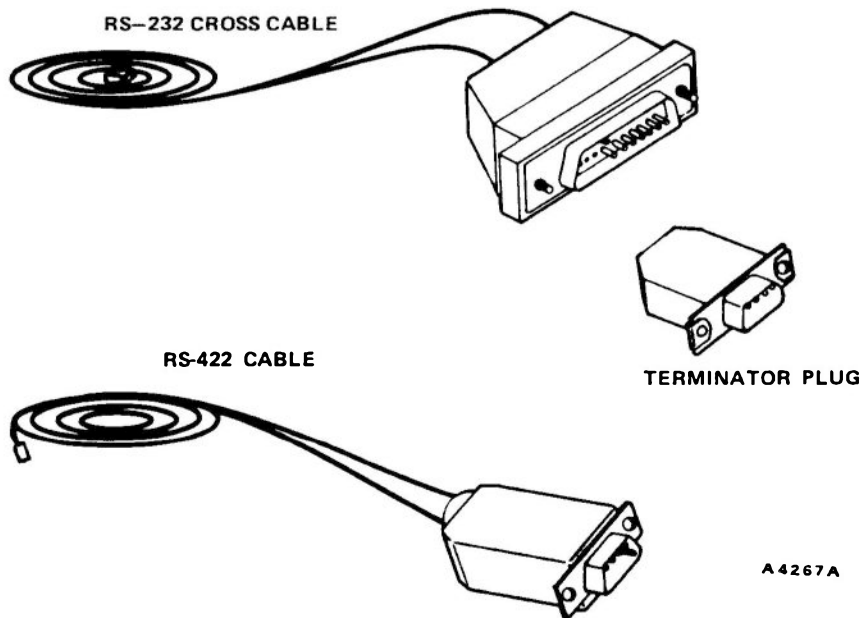

The RS-232 Cross and RS-422 Cables and Terminator Plug

UNPACKING THE MEMORY EXPANSION BOARD

If you have not acquired a memory expansion board, you can skip these unpacking instructions and go to "Installation and Powering-Up the System."

The optional memory expansion board, like the cables box, comes in a box separate from the processing unit and the TM6000 workstation boxes. To open the box, cut the masking tape that is on the edge of the box and open the lid of the box by pulling the flaps open. See the following figure.

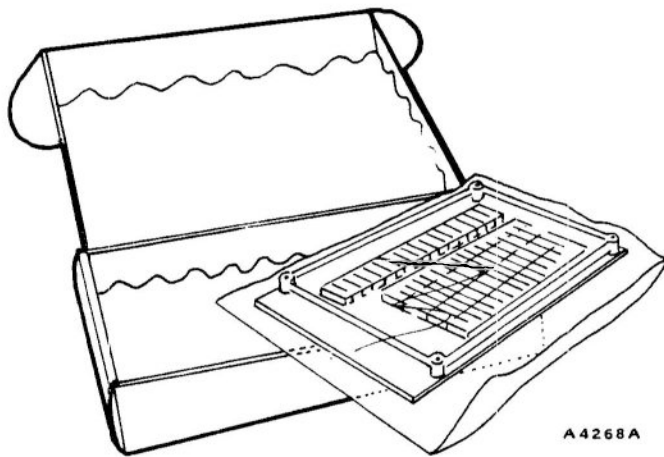

Opening the Memory Expansion Board Box

The memory expansion board, inside the box, is wrapped in static protection plastic. Do not take the memory board out of the plastic wrap until you are ready to install the board into the processing unit. If you are not going to install the board immediately, place it back in the box to protect it.

CAUTION

To prevent damage to the memory board from static electricity discharges, do not lay the memory board on the floor after taking the board out of its protective plastic wrap.

INSTALLING AND POWERING UP THE SYSTEM

Installing and powering up the system is broken into two separate procedures. The first procedure gives instructions on how to install a memory expansion board into the processing unit.

The second procedure shows how to connect the keyboard to the TM6000 video display unit, how to connect the TM6000 workstation to the processing unit, how to connect both the workstation and the processing unit to a power outlet, and how to power up the whole system.

If you have not acquired a memory expansion board, or boards, for your system, skip the procedure about installing the memory expansion board and go on to the next procedure.

Installing a Memory Expansion Board

To install a memory expansion board, perform the following procedure:

- 1 Place the processing unit so that as you face the front of the cabinet there are three feet of clearance on the left side of the cabinet for the cabinet's side panel to open.

DANGER

It is dangerous to go inside the processing unit when its power is on. Look at the rear of the processing unit and make sure that the power switch is OFF. Also, make sure that the ac power cord is disconnected from the unit before opening the unit. See the following figure.

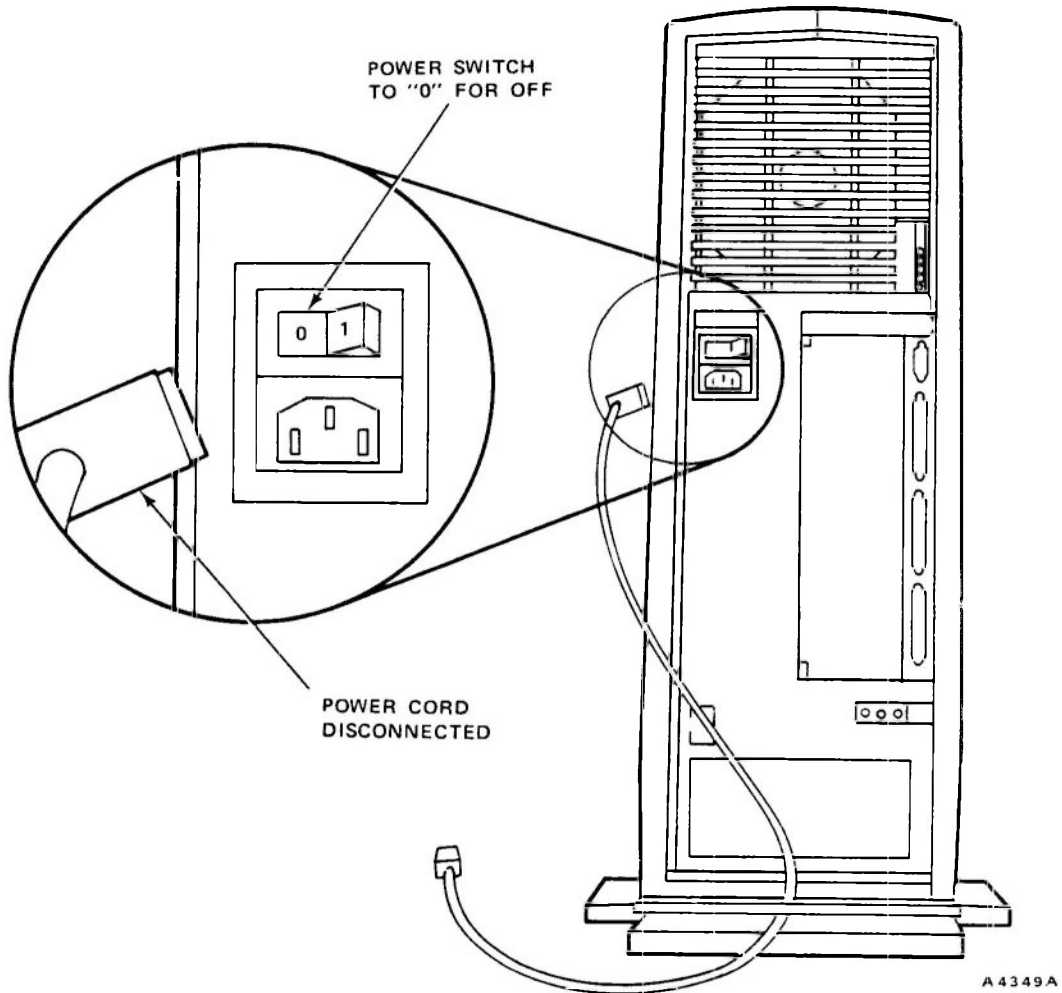

Preparing to Open the Processing Unit

- 2 Insert a small rod shaped tool such as a screwdriver into one of the two small openings located on the top of the processing unit as shown in the following figure.

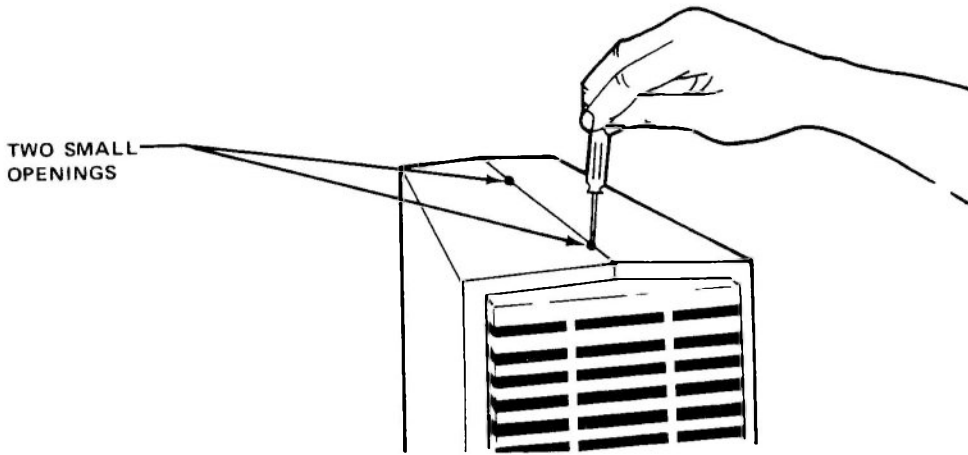

A 4269A

Inserting the Screwdriver

- 3 Once you have the screwdriver in the opening, push down firmly on the screwdriver while you force apart the outer casing, at the seam of the cabinet, until you unlock the first lever lock. See the following figure.

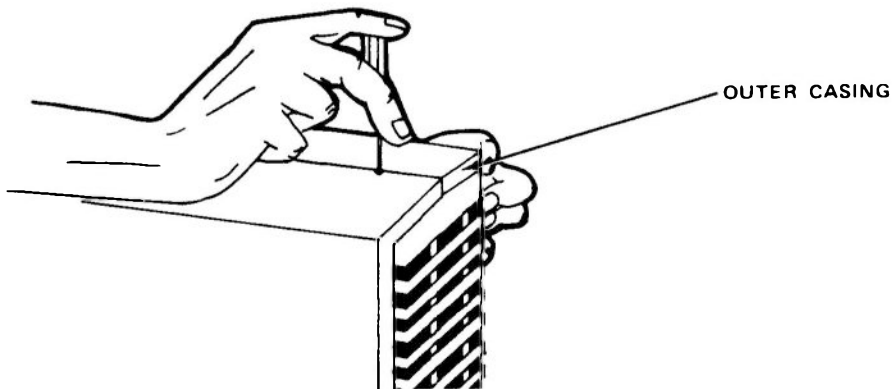

A 4270A

Unlocking a Lever Lock

- 4 Repeat steps 2 and 3 above to unlock the second lever lock. The second lever lock is located in the second small opening at the top of the processing unit.
- 5 Open the cabinet by slowly lowering the cabinet side panel as shown in the following figure.

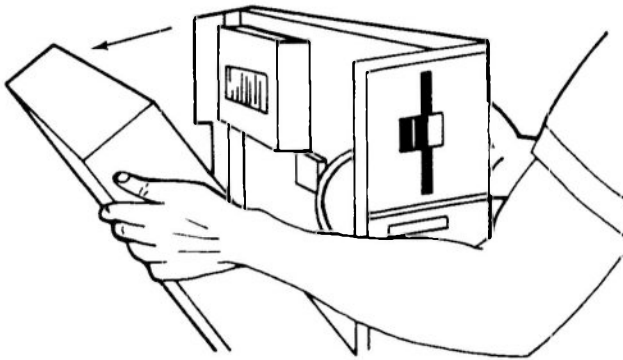

A4271A

Opening the Cabinet

CAUTION

To prevent damage to the processing unit, touch only those parts of the unit that you need to touch to insert the memory expansion board.

- 6 Pull the memory expansion board out of its protective plastic covering and place the board on a table on the board's plastic cover making sure the Zero Insertion Force (ZIF) pins are up and at the front of the board facing you. See the following figure.

CAUTION

The ZIF pins and other electronic components on the memory expansion board are easily damaged, so handle the board from the outside bars to avoid damage.

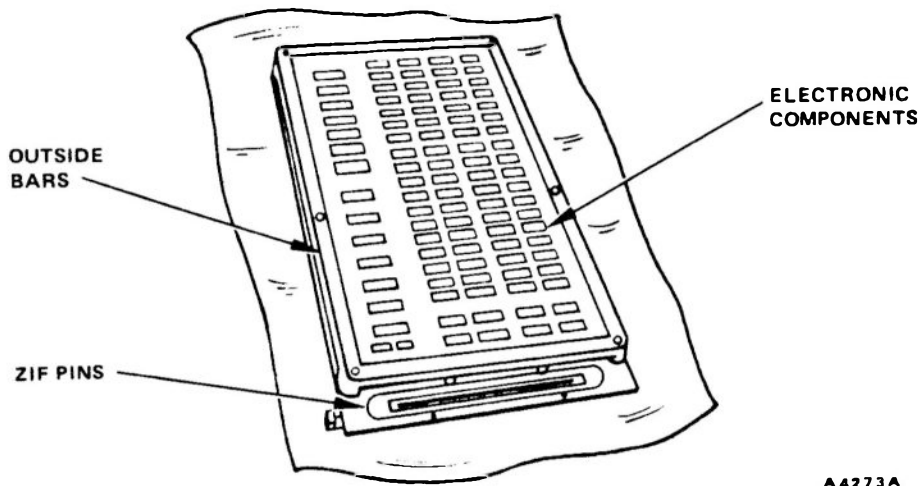

A 4273A

The Memory Expansion Board

- 7 Each memory expansion board has two memory addressing jumpers to set the memory address range for the board. Locate these jumpers; they are located on the front left part of the board labeled either MA19 and MA20 or E2 and E1. See the following figure.

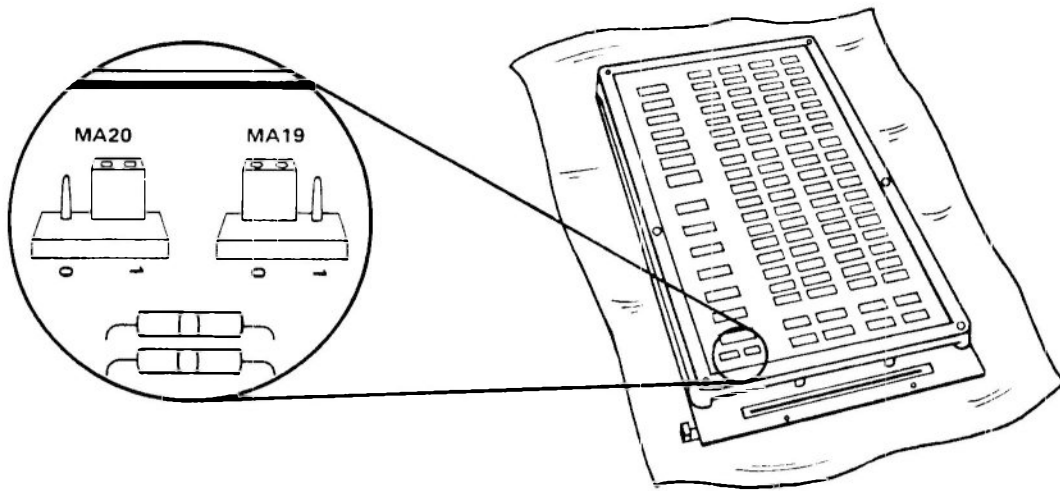

A 4274A

Locating the Memory Address Jumpers

- 8 Determine if the memory address jumpers are set in the appropriate position by comparing the expansion board's jumper positions to the following illustrations:

NOTE: Your processing unit will come with the first expansion board factory installed. You will be adding either a second, or a second and a third expansion board. Each board has a different setting.

NOTE: The jumpers are set by placing them over two of three pins available. As you face the board, a jumper is set to OFF if the jumper sits over its left pin (0) and its middle pin (neutral). A jumper is set to ON if it sits over its right pin (1) and middle pin (neutral).

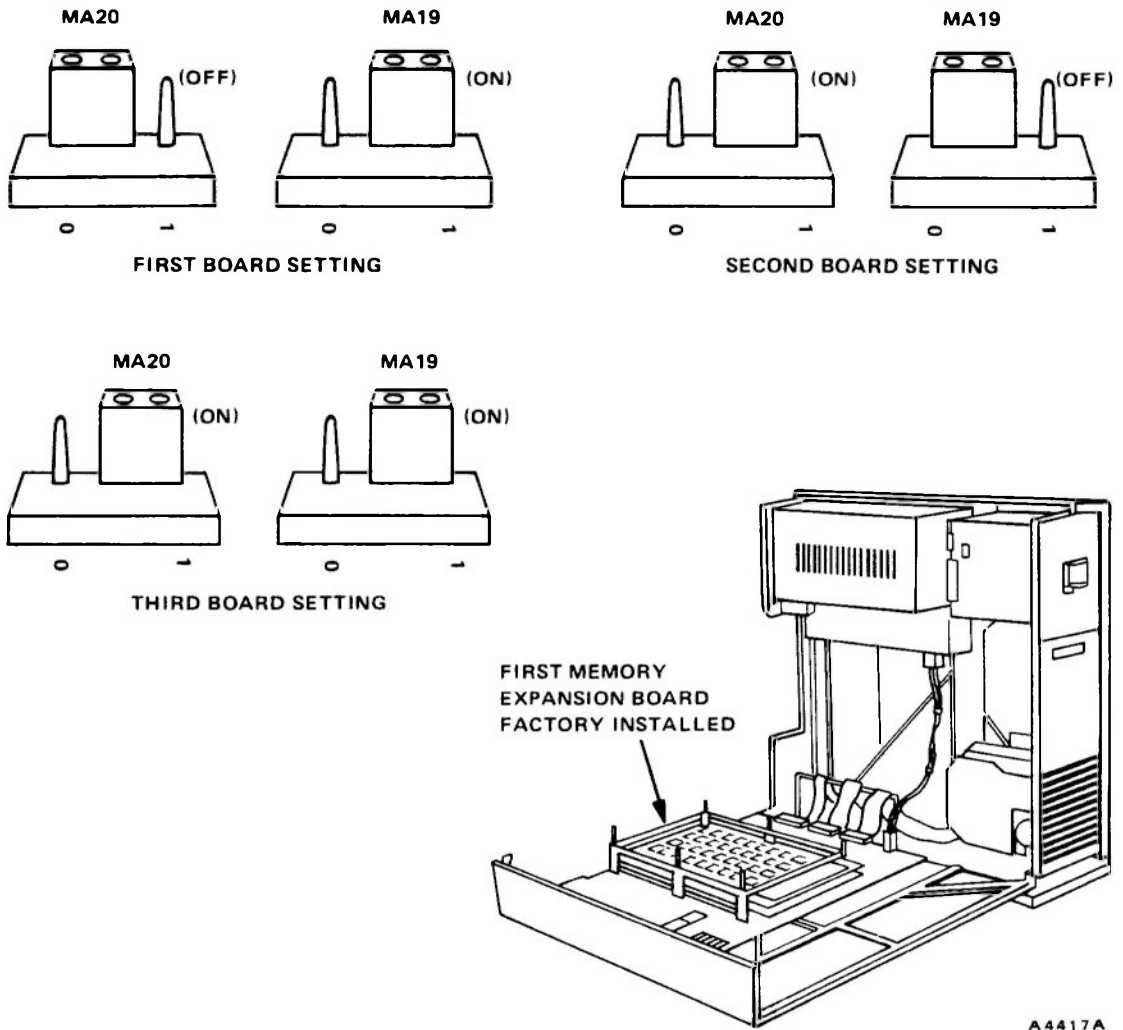

Memory Address Jumper Settings

- 9 If the memory address jumpers are in the incorrect position on any of the expansion boards, gently pull out the incorrectly positioned jumpers and push the jumpers over the correct pins indicated in the previous illustrations.

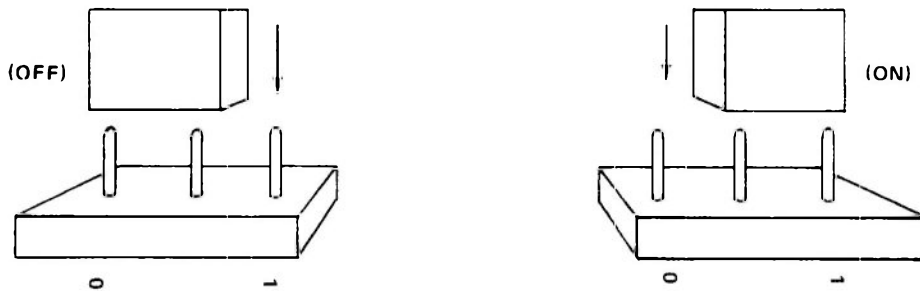

A4275A

Setting the Memory Address Jumpers

- 10 With the memory board positioned so that the ZIF pins are towards the front of the board, pull the ZIF latch out as shown in the following figure.

NOTE: The Zero Insertion Force (ZIF) pins are fragile. Be careful not to bend any of these pins.

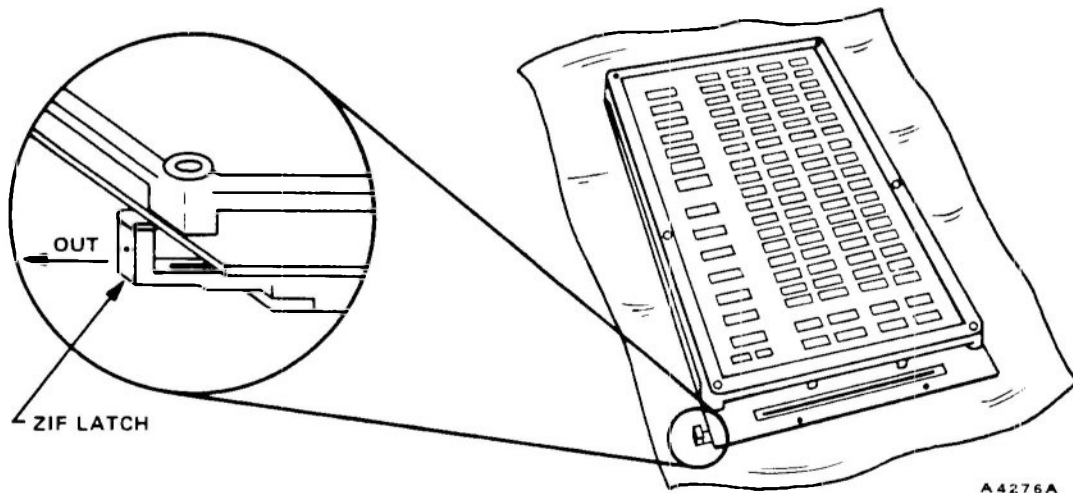

A4276A

Pulling Out the ZIF Latch

- 11 Remove the six thumbnuts located on the six threaded stud bolts by unscrewing the thumbnuts counterclockwise as shown in the following figure.

CAUTION

To prevent damage to the board's electronic components and ZIF pins, avoid dropping the thumbnuts on them.

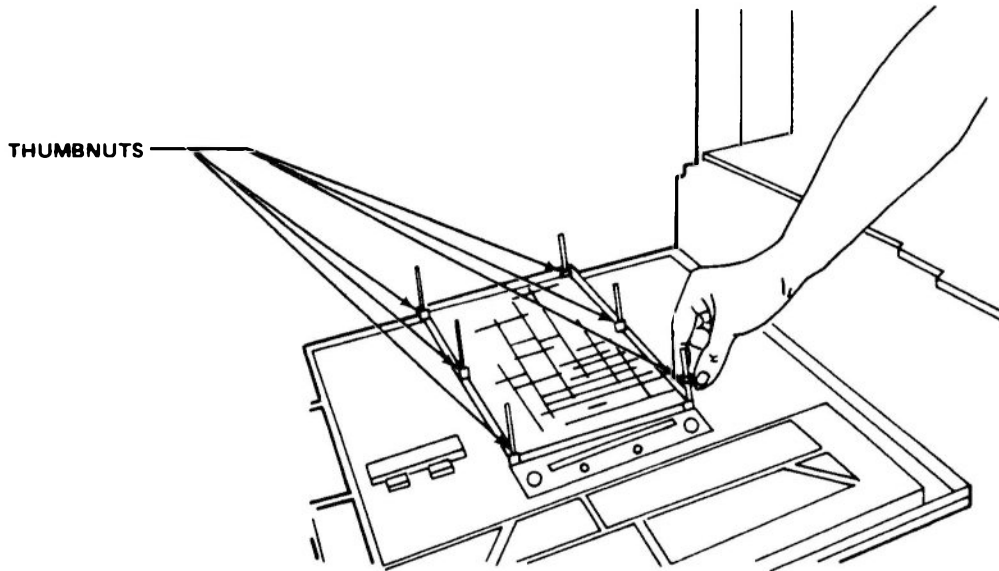

A4272A

Removing the Six Thumbnuts

- 12 Place the memory expansion board's stud bolt holes over the processing unit's six threaded stud bolts and, while holding the board with one hand, insert the stud bolts into the stud bolt holes. You may have to move the stud bolts a little to get them to fit into the board's stud bolt holes. See the following figure.

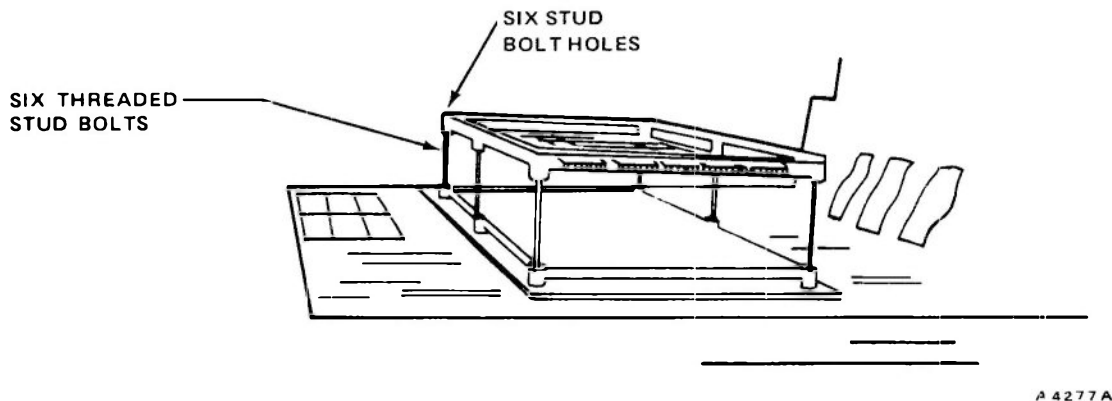

Inserting the Stud Bolts into the Stud Bolt Holes

- 13 Slide the memory expansion board down **slowly** over the stud bolts to ensure that the board doesn't suddenly slam down and bend the lower board's ZIF connector pins. Slide the memory expansion board down until its ZIF connector almost touches the lower board's ZIF pins.

CAUTION

Make sure to slide the memory expansion board down evenly over the stud bolts keeping it parallel to the lower board. This ensures that the memory expansion board's ZIF connector lines up with the lower board's ZIF pins for an easy insertion that won't bend any pins. See the following figure.

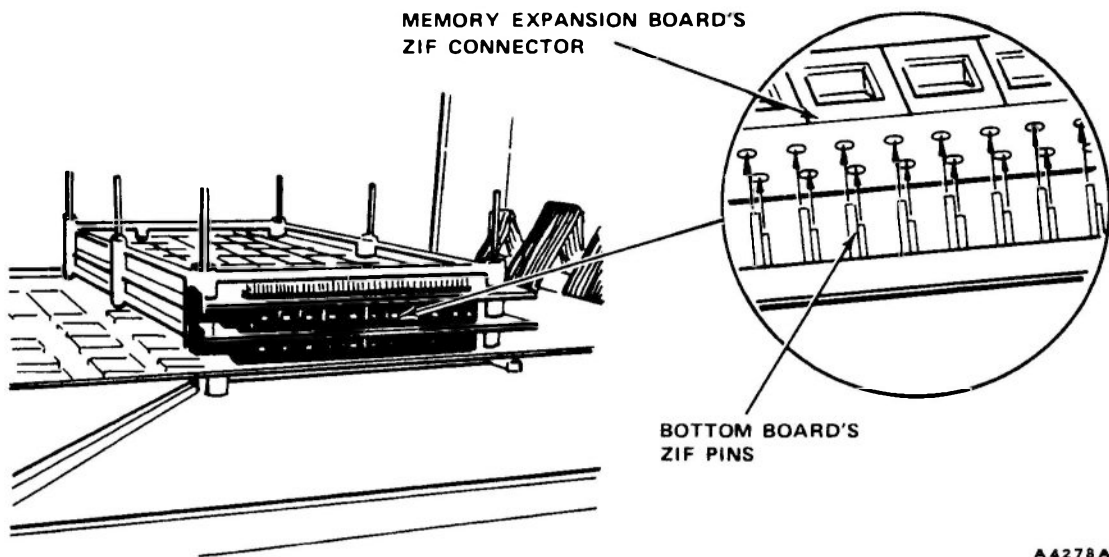

A4278A

Sliding the Memory Expansion Board Down

- 14 Line up the memory expansion board's ZIF connector with the lower board's ZIF pins and gently insert the memory expansion board until the memory expansion board is connected securely to the lower board.

CAUTION

ZIF stands for Zero Insertion Force, which means that the ZIF pins insert into the ZIF connector without force. Therefore, use care when mating the ZIF pins with the ZIF connector, as force can cause damage. Also, the ZIF connector pins must be clean and straight to ensure proper insertion.

- 15 After you have inserted the added memory expansion board into the lower board, push in the ZIF latch as shown in the following figure.

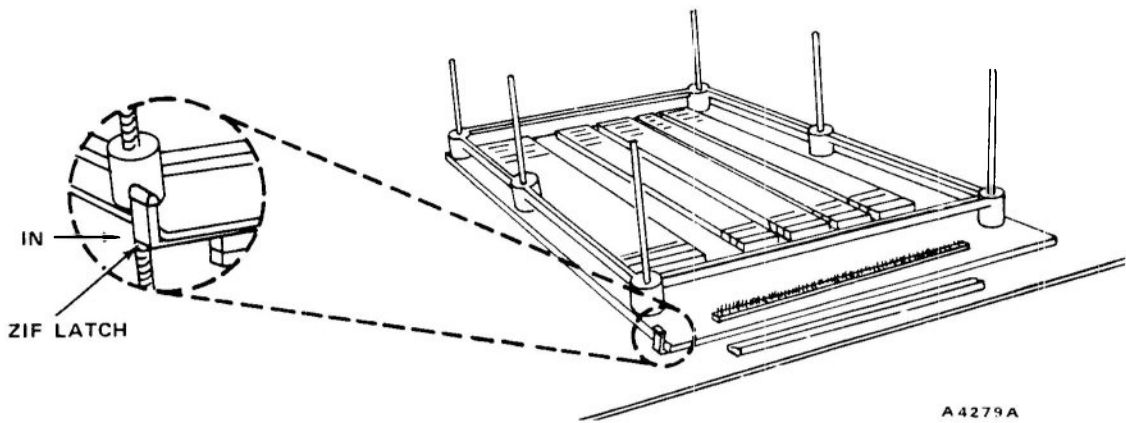

Pushing in the ZIF Latch

- 16 If you have more than one memory expansion board to add to your processing unit, repeat the steps 6 through 15 for the next memory board installation.
- 17 After you have inserted the memory boards, screw on the six thumbnuts snugly to secure the boards.

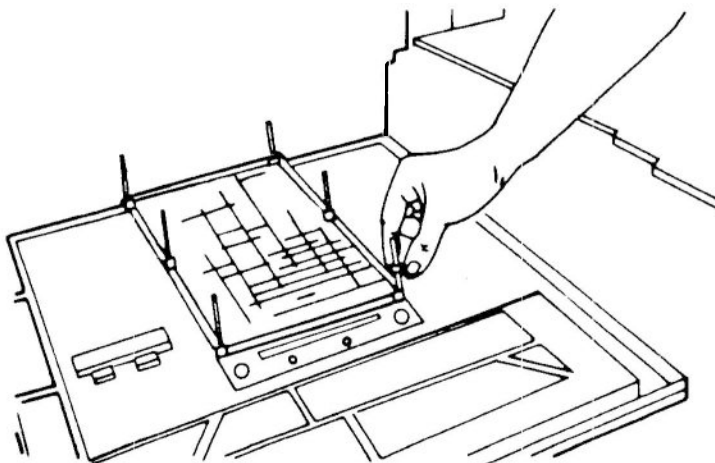

Screwing on the Thumbnuts

- 18 After you have checked that all the latches and thumbnuts are on securely and that there are no tools inside the unit, close the processing unit by bringing up the side panel and snapping it closed.

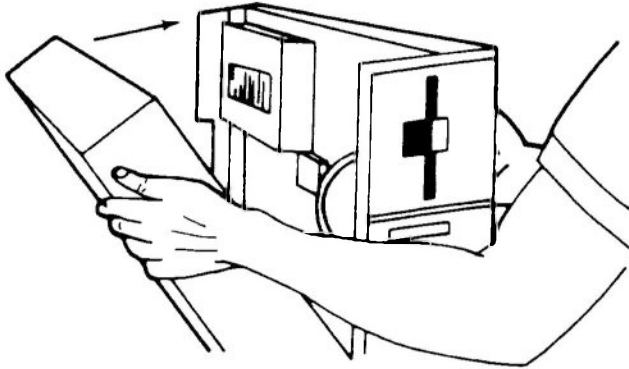

A 4281 A

Closing the Processing Unit Side Panel

Installing and Powering Up the System 6300

Go through the following steps to install and power up the System 6300:

- 1 As you face the video display unit, insert either end of the coiled cable into the connector on the right side of the video display unit's base labeled "keyboard." Press the clear plastic on either side of the cable end and while holding the clear plastic pressed, insert into the connector. See the following figure.

CAUTION

Make sure that you insert the coiled cable and not the flat power cable into the keyboard connector. These cables have similar ends and both can fit into the keyboard connector.

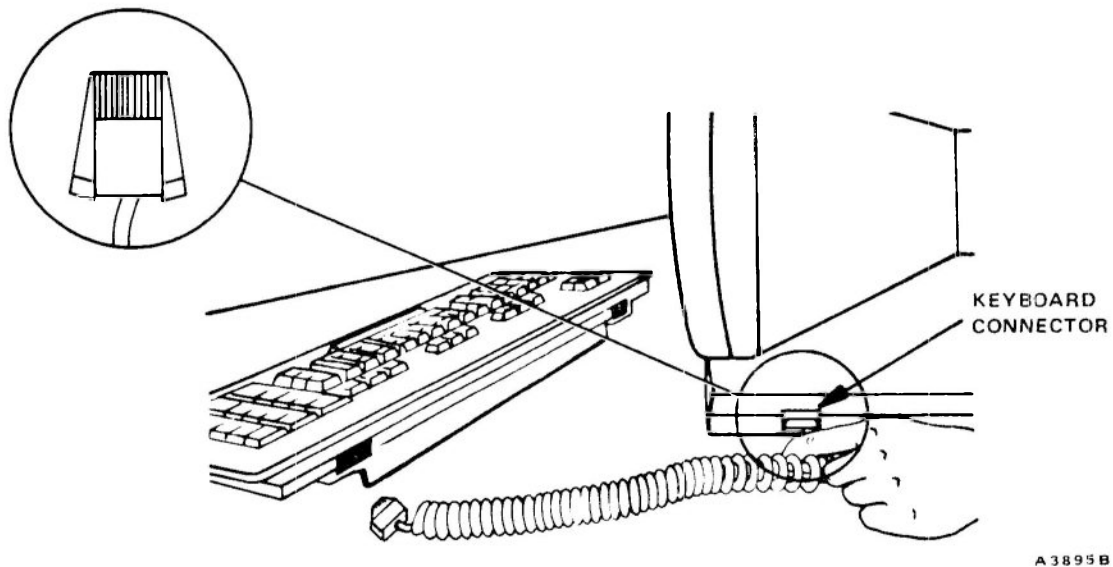

Inserting the Coiled Cable into the Video Display Unit

- 2 Insert the other end of the coiled cable into one of the two connectors located on the back side of the keyboard. Press the clear plastic on either side of the cable end and, while holding the plastic pressed, insert into the connector. See the following figure.

NOTE: If you want to adjust your keyboard to sit higher, pull down the keyboard flap located on the back underside of the keyboard between the two keyboard connectors.

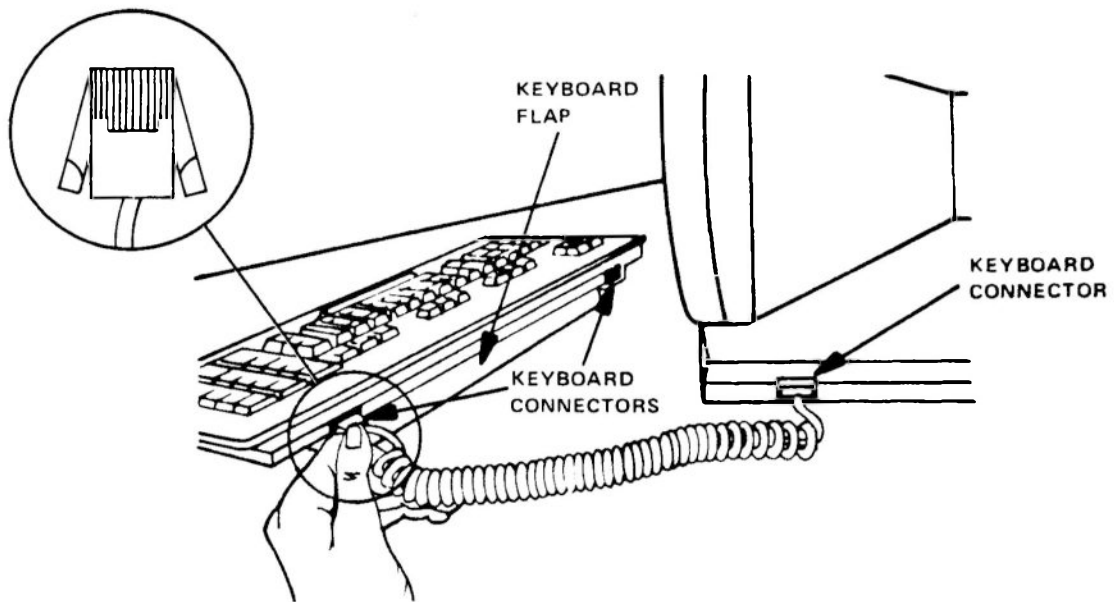

A4282A

Inserting the Coiled Cable into the Keyboard

- 3 Turn the video display unit around so that you face the back of the unit.
- 4 Insert the RS-232 Cross cable into the serial connector located on the rear of the base assembly of the video display unit. See the following figure.

NOTE: The RS-232 Cross cable is used only to connect the first terminal to the processing unit.

NOTE: Make sure to screw in the connector retaining screws after you insert the RS-232 Cross cable to secure the connection.

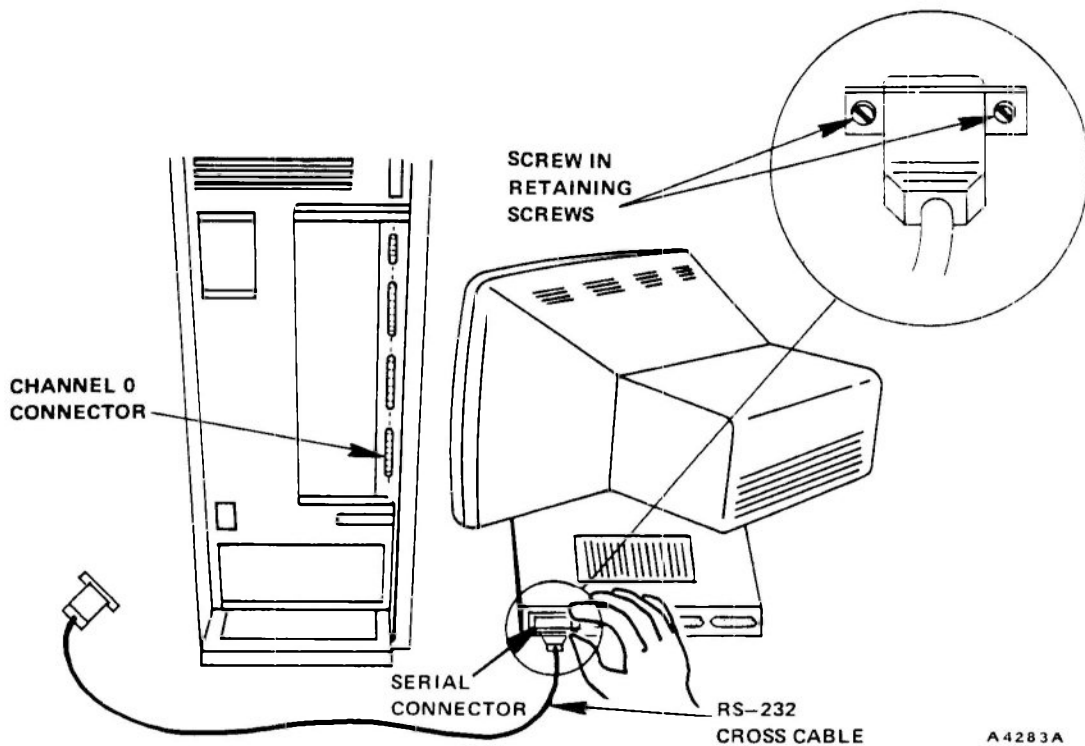

Inserting the RS-232 Cross Cable into the Serial Connector

- 5 Insert the other end of the RS-232 Cross cable into the channel 0 connector located on the rear of the processing unit as shown in the following figure.

NOTE: Screw in the connector retaining screws after you insert the RS-232 Cross cable to secure the connection.

CAUTION

To avoid tripping over cables or cords, thread all your cables and power cords coming from the processing unit through the cable guide located on the lower rear of the processing unit. To prevent damage to the processing unit, avoid using the cable guide as a handle to lift the unit.

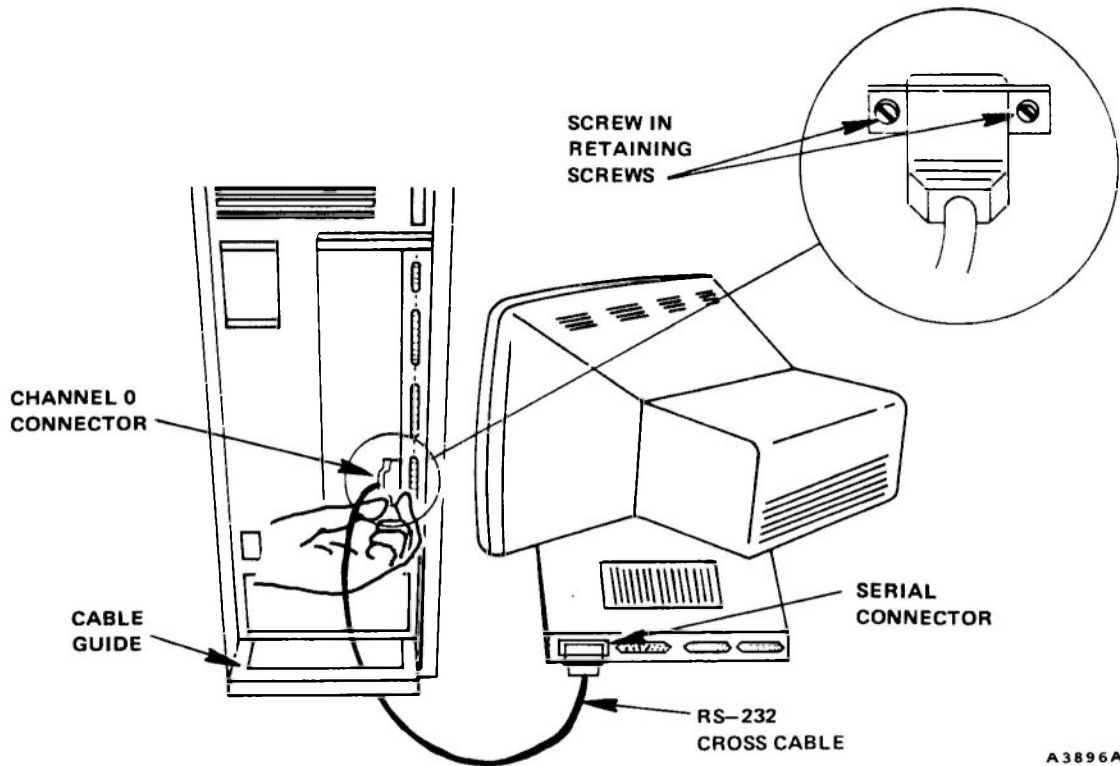

Inserting the RS-232 Cross Cable into the Channel 0 Connector

- 6 Insert either end of the RS-422 cable into either of the cluster communication connectors located on the rear of the video display unit's base assembly. See the following figure.

NOTE: Screw in the connector retaining screws after you insert the RS-422 cable to secure the connection.

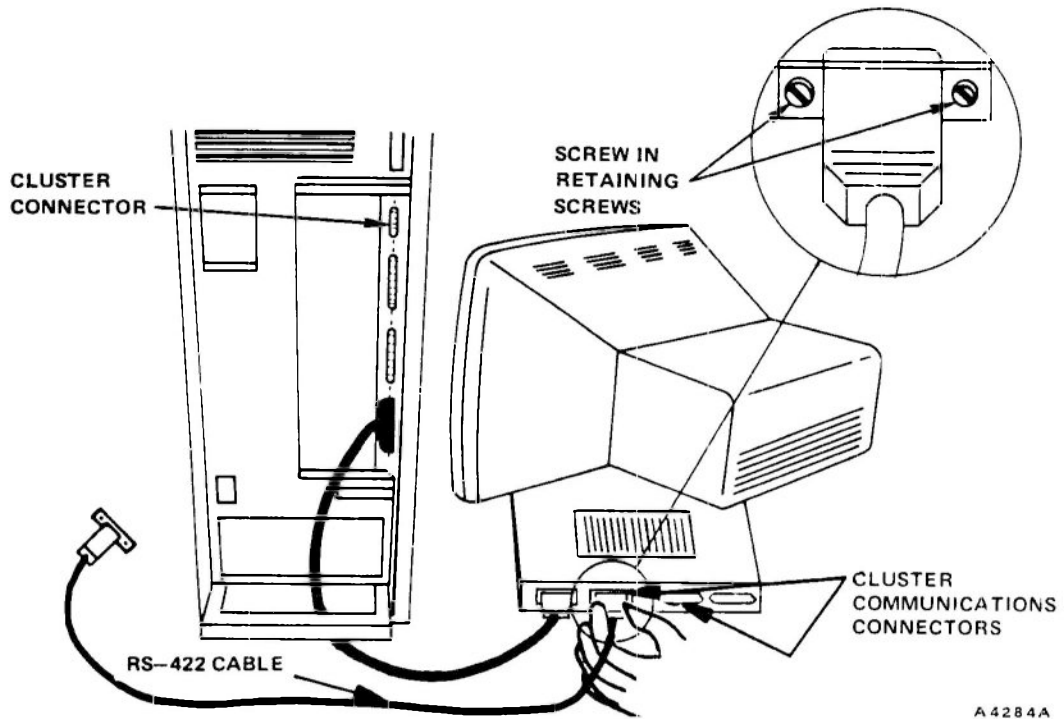

Inserting the RS-422 Cable into the Cluster Communications Connector

- 7 Insert the other end of the RS-422 cable into the cluster connector located on the rear of the processing unit as shown in the following figure.

NOTE: Screw in the connector retaining screws after you insert the RS-422 cable to secure the connection.

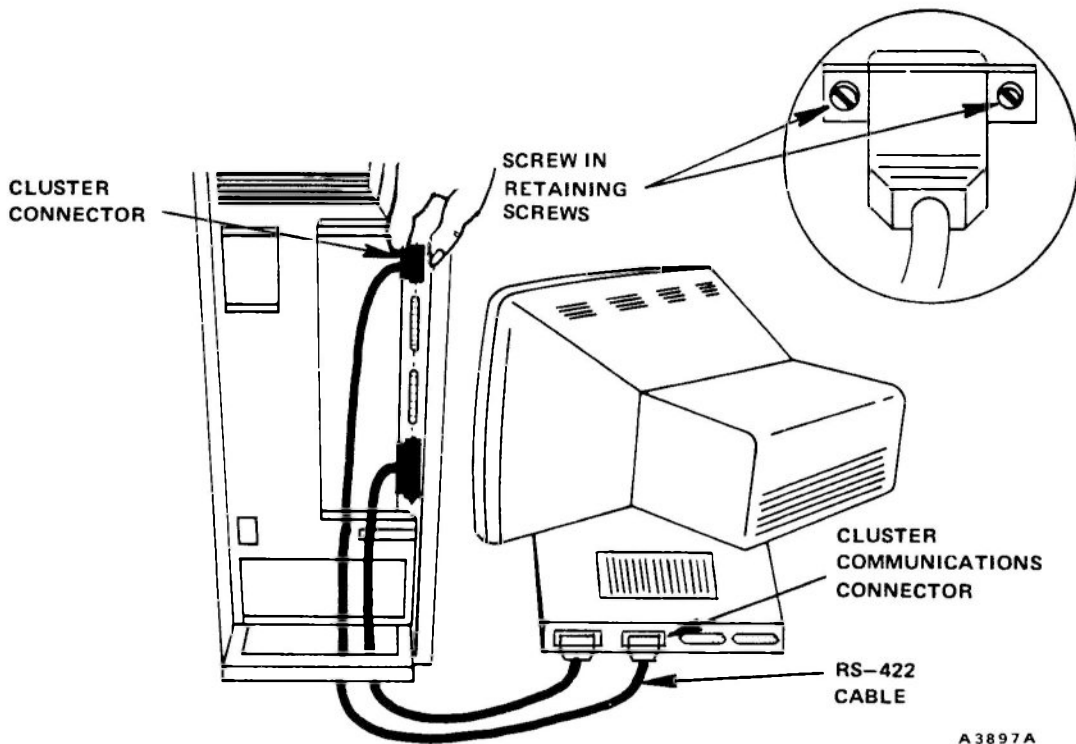

Inserting the RS-422 Cable into the Cluster Connector

- 8 To get electrical power to your terminal, start by inserting the flat power cable into the power connector located on the rear of the video display unit's base. To do this, press the clear plastic on either side of the cable end and while holding the clear plastic pressed, insert into the connector. See the following figure.

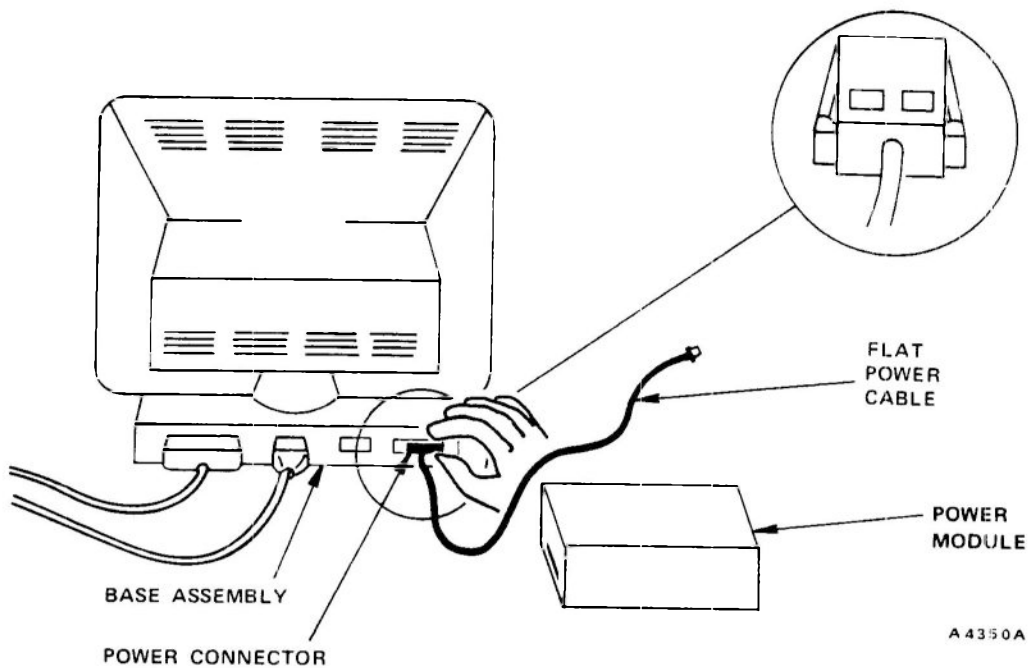

Inserting the Flat Power Cable into the Terminal

- 9 While pressing the clear plastic on either side of the cable end, insert the other end of the flat power cable into the power module. See the following figure.

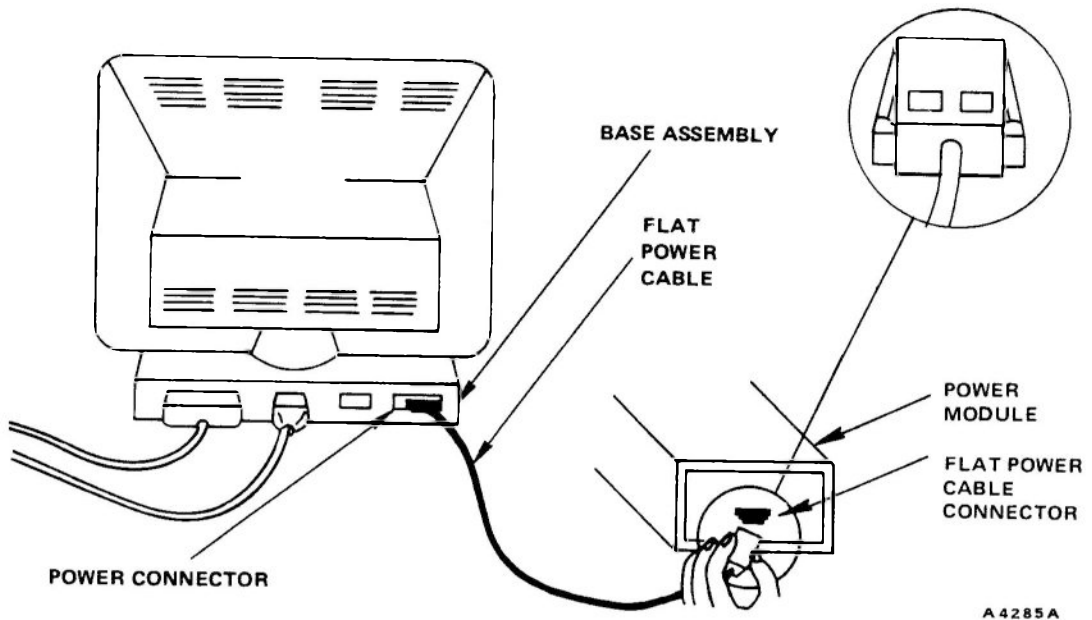

A 4285A

Inserting the Flat Power Cable into the Power Module

- 10 Pull back the black sticker on the power module to see if the voltage selection switch is set to 115 VAC or 220 VAC. The switch setting should match the voltage output of your electrical outlet. If incorrectly set, change to the correct setting. See the following figure.

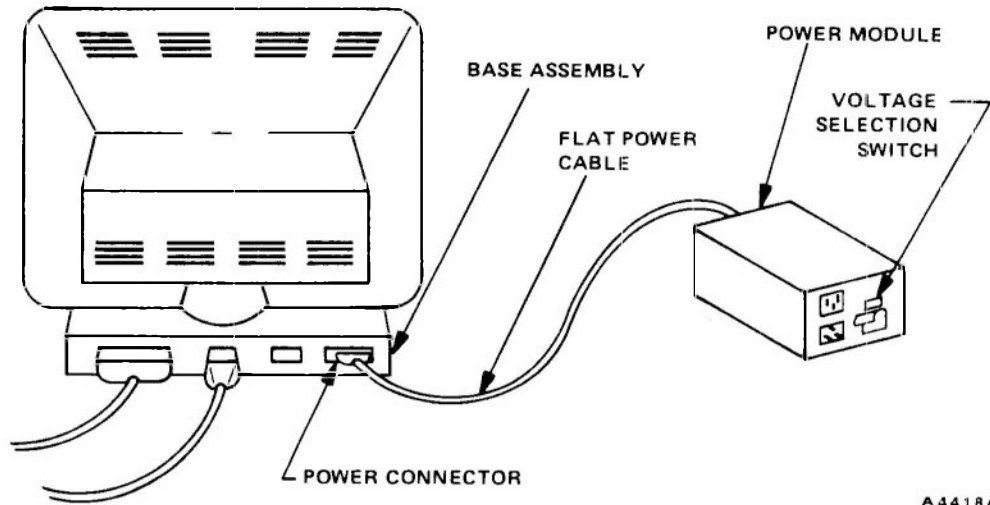

A4418A

Checking the Voltage Selection Switch

- 11 Insert the female end of the power module's long power cord into the male connector on the power module. See the following figure.

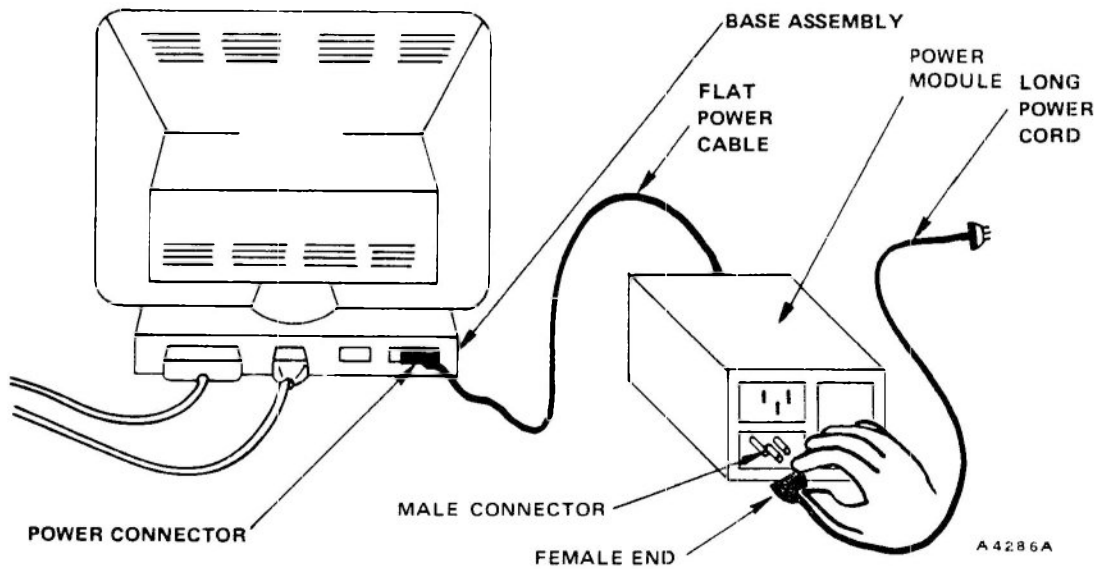

A4286A

Inserting the Long Power Cord into the Power Module

- 12 Insert the other end of the power module's long power cord into a grounded three-hole electrical outlet to get power to your terminal. See the following figure.

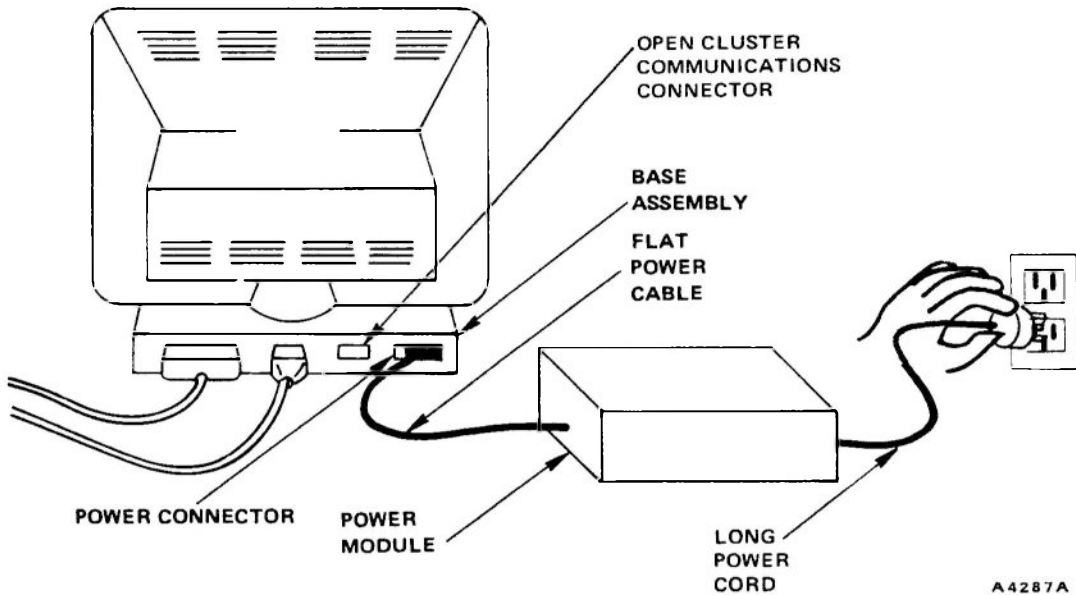

Inserting the Long Power Cord into the Electrical Outlet

NOTE: If you are connecting more than one terminal to your system, go through the following steps, otherwise place a terminator plug into the open cluster communications connector (see previous figure), and go on to step 23.

- 13 As you face the rear of the terminal, insert either end of an RS-422 cable into the open cluster connector of the first terminal in your cluster of terminals as shown in the following figure.

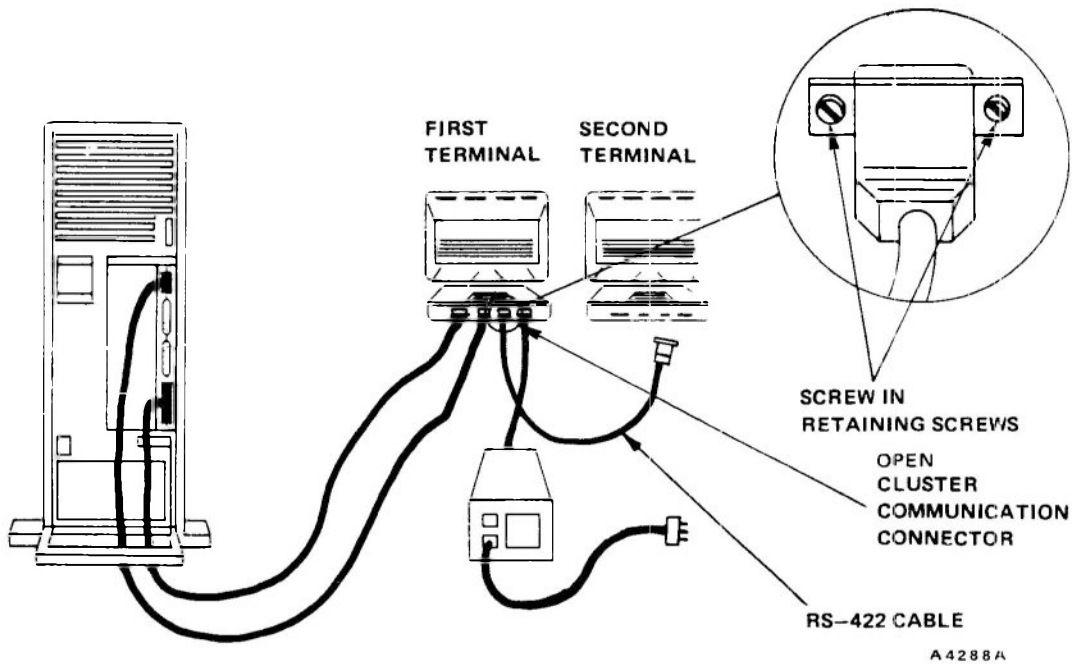

Inserting the RS-422 Cable into the Open Cluster Connector

- 14 Insert the other end of the RS-422 cable into one of the cluster communications connectors of your second terminal as shown in the following figure.

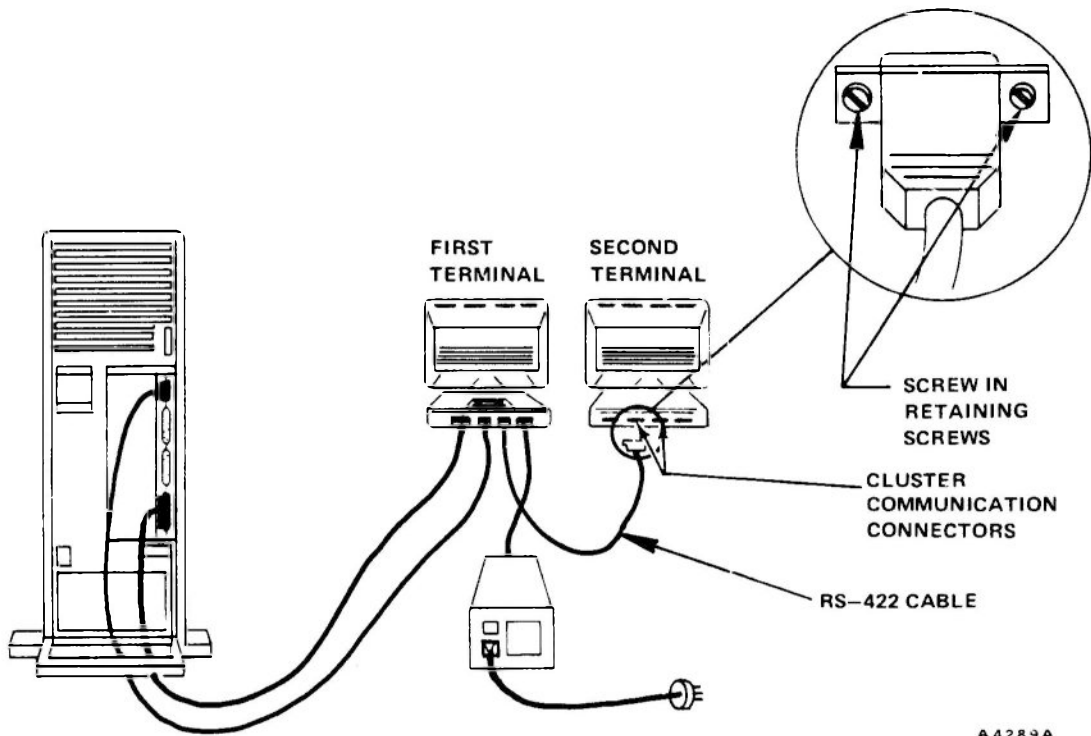

A4289A

Inserting the RS-422 Cable into the Second Terminal

NOTE: Go through steps 13 and 14 until you have connected as many terminals onto your system as you need up to the limit of eight terminals.

- 15 After you have connected as many terminals as you need, make sure to insert a terminator plug into the open cluster communications connector of the last terminal in your cluster, otherwise your terminals will not operate correctly. See the following figure.

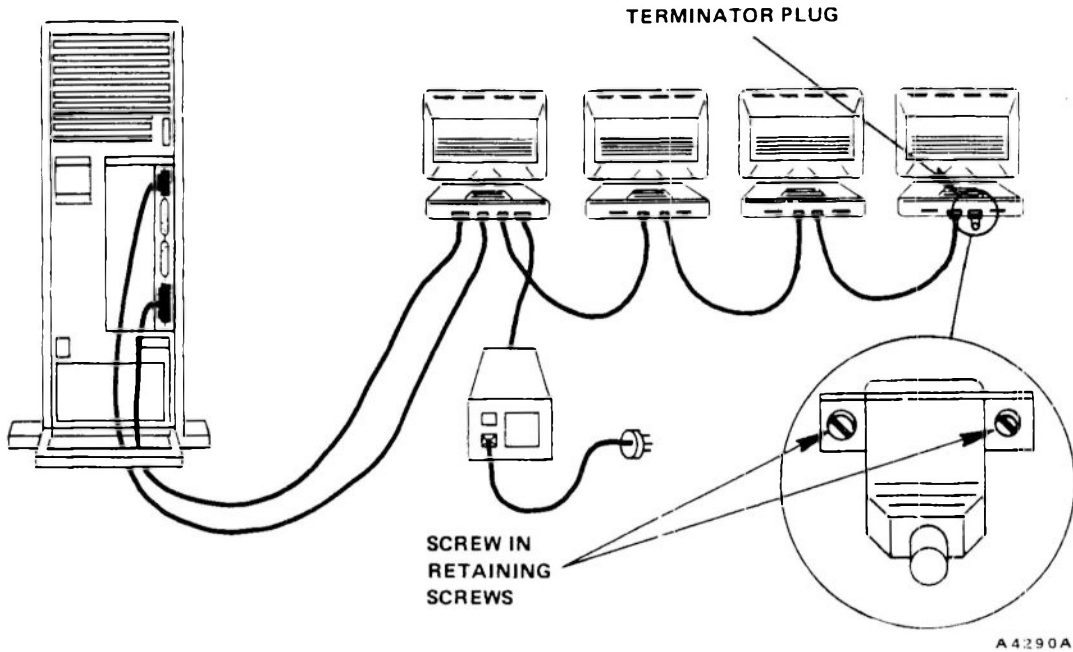

Inserting a Terminator Plug into the Last Terminal

NOTE: You have two options to connect your cluster of terminals to a source of electrical power. The following steps show you both options:

- 16 In the first option, you can connect each terminal in your cluster of terminals directly to an electrical outlet by following the previous steps 8 through 12. The connected terminals should look as shown in the following figure.

NOTE: Since you have performed the previous steps 8 through 12 once, the first terminal in your cluster of terminals is already connected to an electrical outlet. You have to connect the remaining terminals.

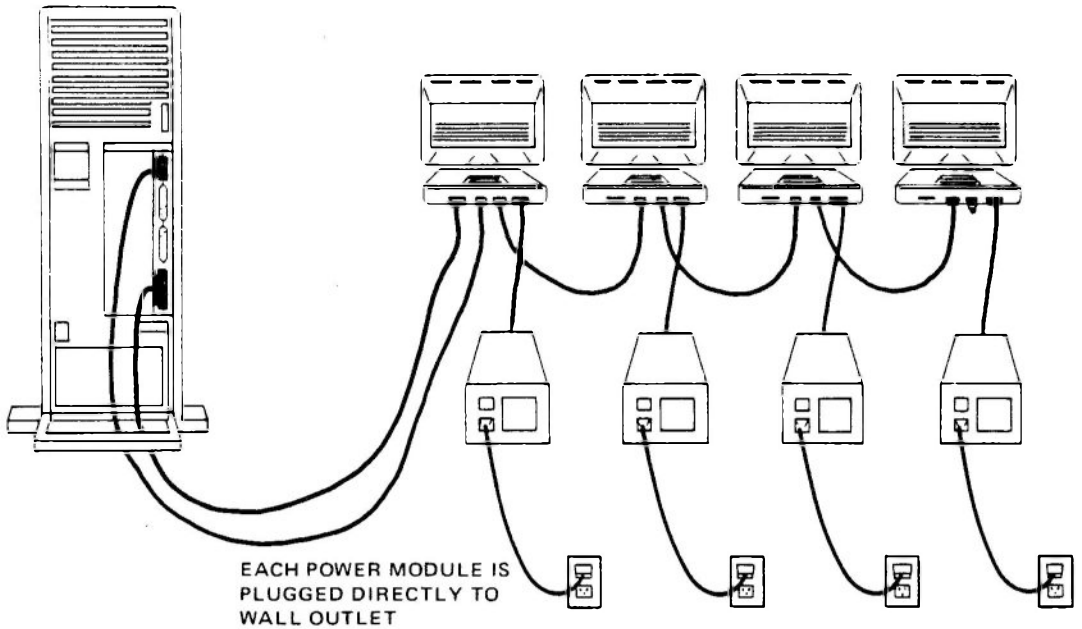

A 4291 A

Plugging a Cluster of Terminals Directly to the Electrical Outlet

- 17 For the second option, you start by connecting each terminal to its power module and checking each power module's voltage switch setting as per steps 8 through 10 above. See the following figure.

NOTE: Since you have performed the previous steps 11 and 12, the power module of your first terminal in your cluster of terminals is connected to an electrical outlet with a long power cord. Disconnect this long power cord from both the electrical outlet and the power module.

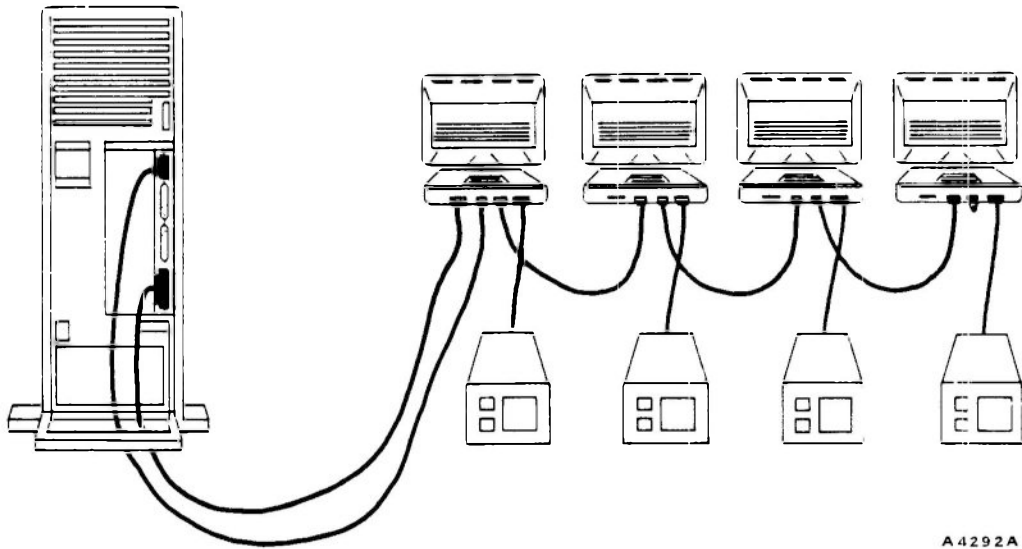

A 4292A

Each Terminal Connected to Its Power Module

- 18 Next, insert the female end of the short power cord provided with each power module (the cord is about 12 inches long) into the male connector of the first terminal's power module. See the following figure.

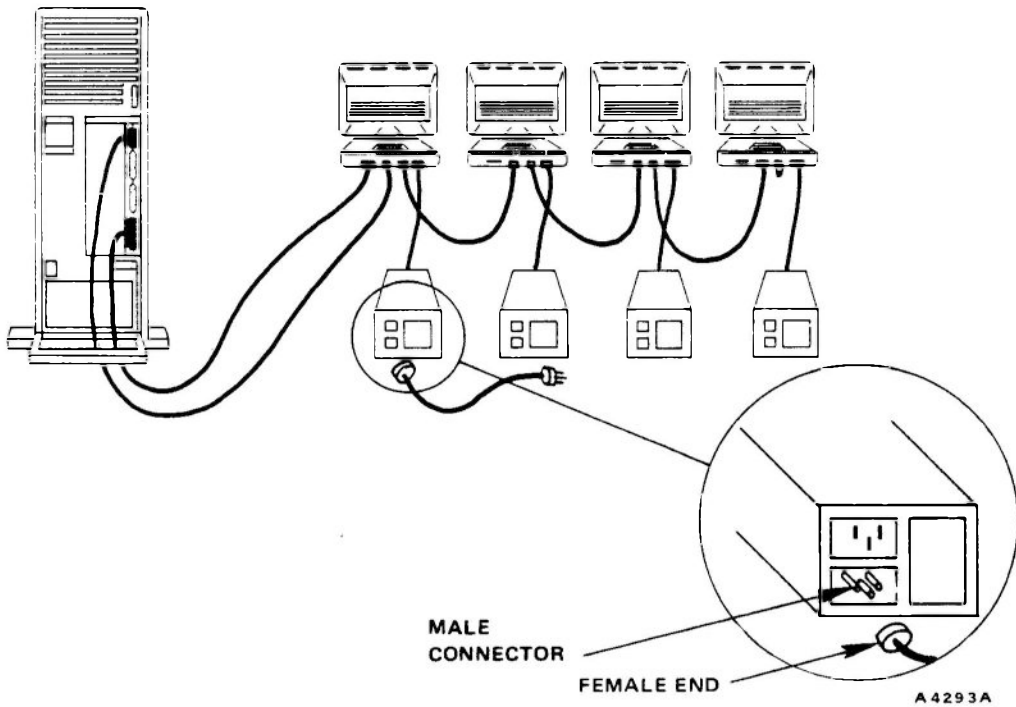

**Inserting the Short Power Cord
into the First Terminal's Power Module**

- 19 Insert the male end of the short power cord into the female connector of the second terminal's power module as shown in the following figure.

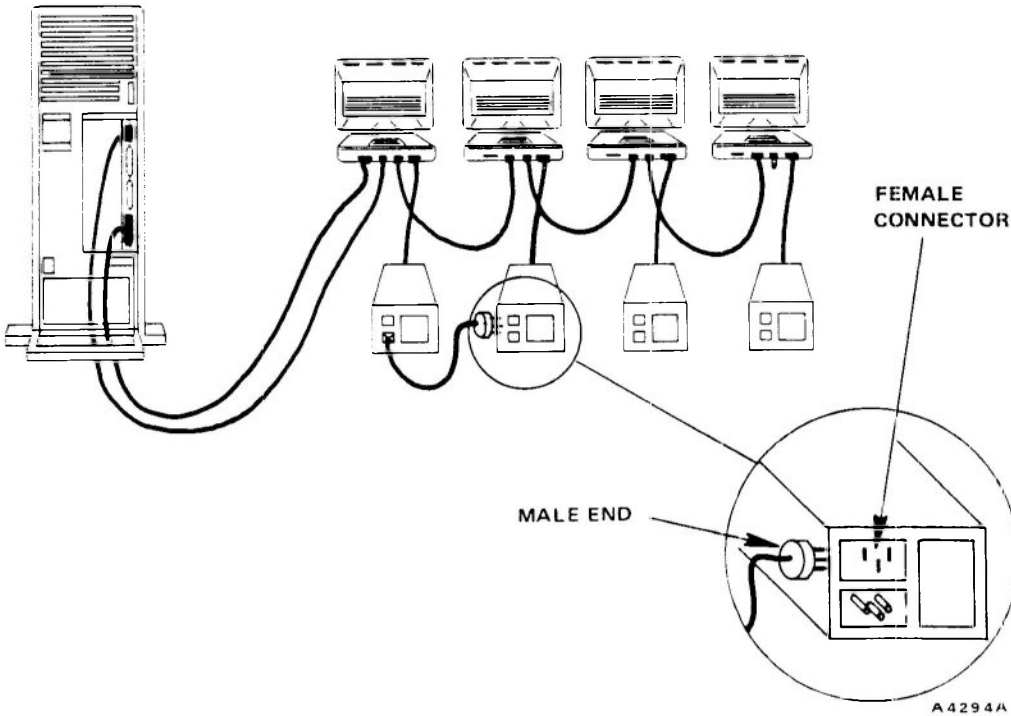

Inserting the Short Power Cord into the Second Terminal's Power Module

NOTE: You can only connect two power modules to each other in the fashion described in steps 18 through 19 above, then you must connect the second power module to an electrical outlet as will be described in steps 20 and 21 that follow.

- 20 Insert the long power cord's female end into the second power module's male connector as shown in the following figure.

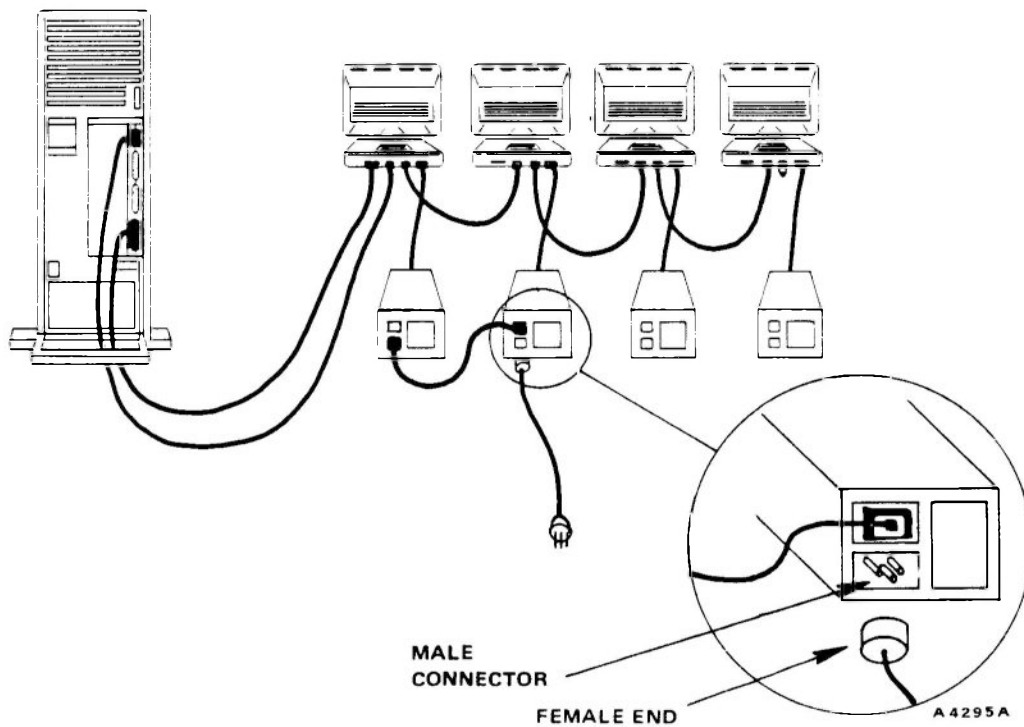

Inserting the Long Power Cord into the Second Power Module

- 21 Insert the long power cord's male end into a grounded three-hole electrical outlet. See the following figure.

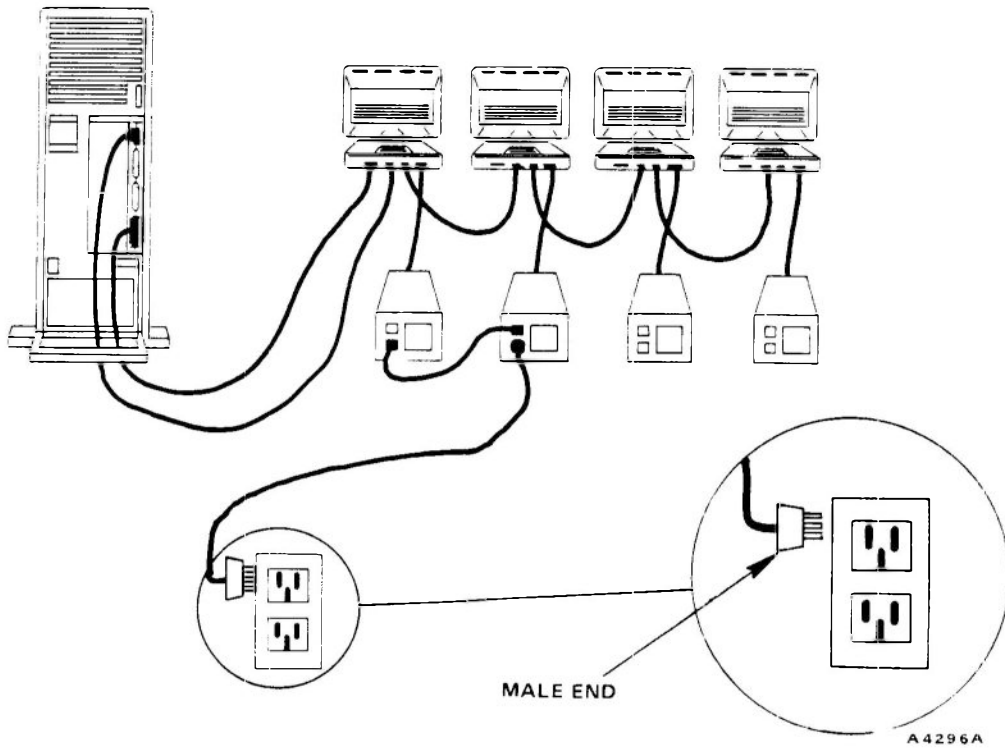

Inserting the Long Power Cord into an Electrical Outlet

22 Connect every two power modules in your cluster of terminals as explained in steps 18 through 21 above until all the power modules have a source of electrical power. Your setup should look as shown in the following figure.

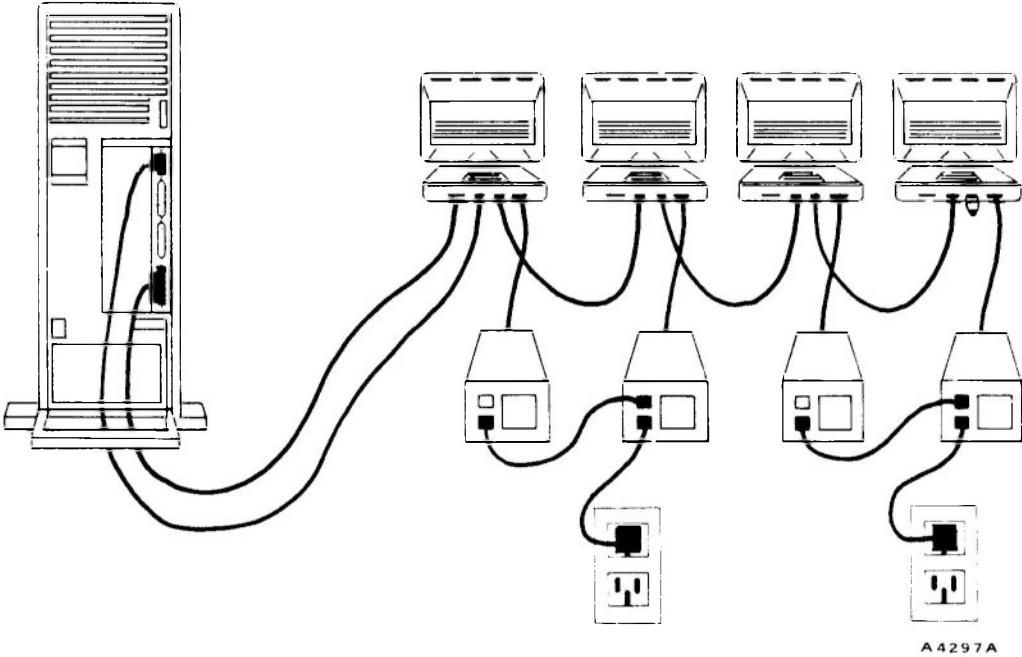

Connecting One Power Module to Another
then to an Electrical Outlet

- 23 Next, you must connect the processing unit to a grounded electrical outlet. To do this you plug in the female end of the processing unit's power cord into the processing unit's male power cord connector. See the following figure.

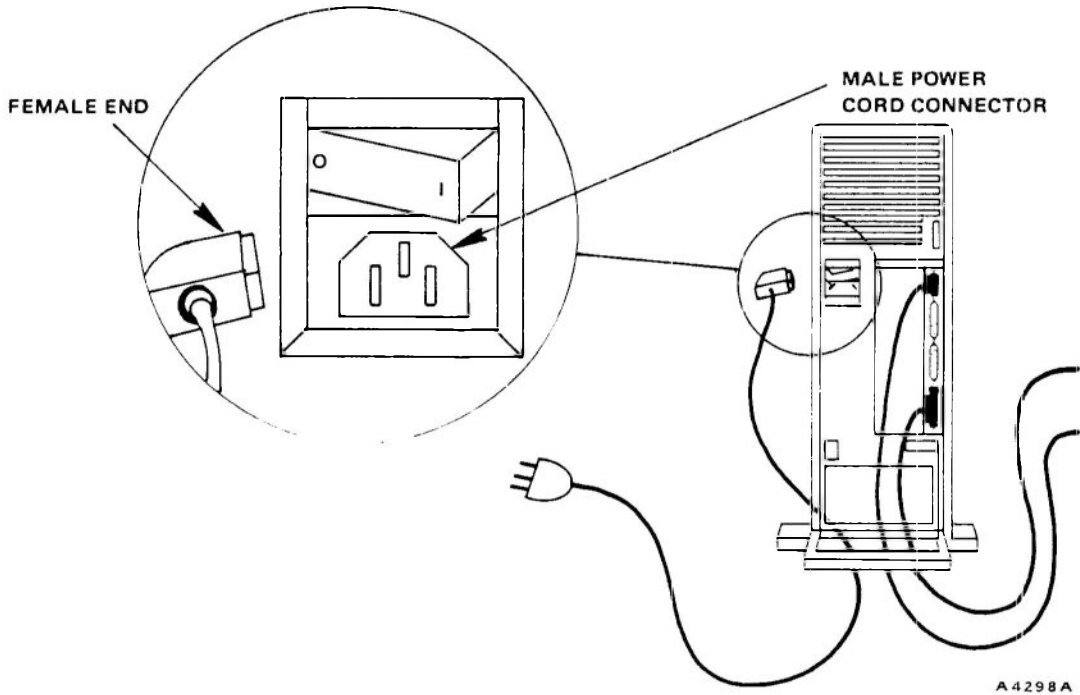

Inserting the Processing Unit's Power Cord
into the Processing Unit

- 24 Insert the male end of the processing unit's power cord into a grounded three-hole electrical outlet as shown in the following figure.

NOTE: Check to make sure that the voltage indicated on lower left rear side of the processing unit matches the voltage of your electrical outlet. If your unit's indicated voltage does not match your electrical plug voltage, contact your Field Engineer for help.

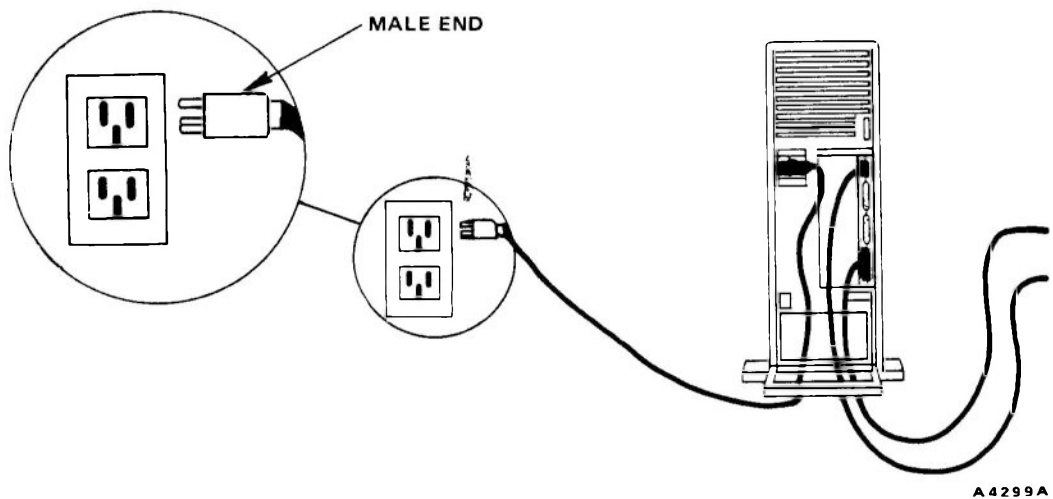

Inserting the Processing Unit's Power Cord into an Electrical Outlet

- 25 Turn on the processing unit's I/O power switch, located directly above the power cord connector, by pressing the switch to the "I" position. See the following figure.

NOTE: The indicator labeled number 2, located on the rear of the processing unit, lights when the processing unit's I/O power switch is turned on. If the indicator does not light, indicating that the processing unit has not turned on, do the following steps in order until you find one that solves the problem:

- Check to see if the power cord is securely connected both into the processing unit and into the electrical outlet.
- Make sure that the electrical outlet is live by switching on any switch that may give power to your electrical outlet.
- If neither of the two steps above light the indicator, call your Field Engineer for help.

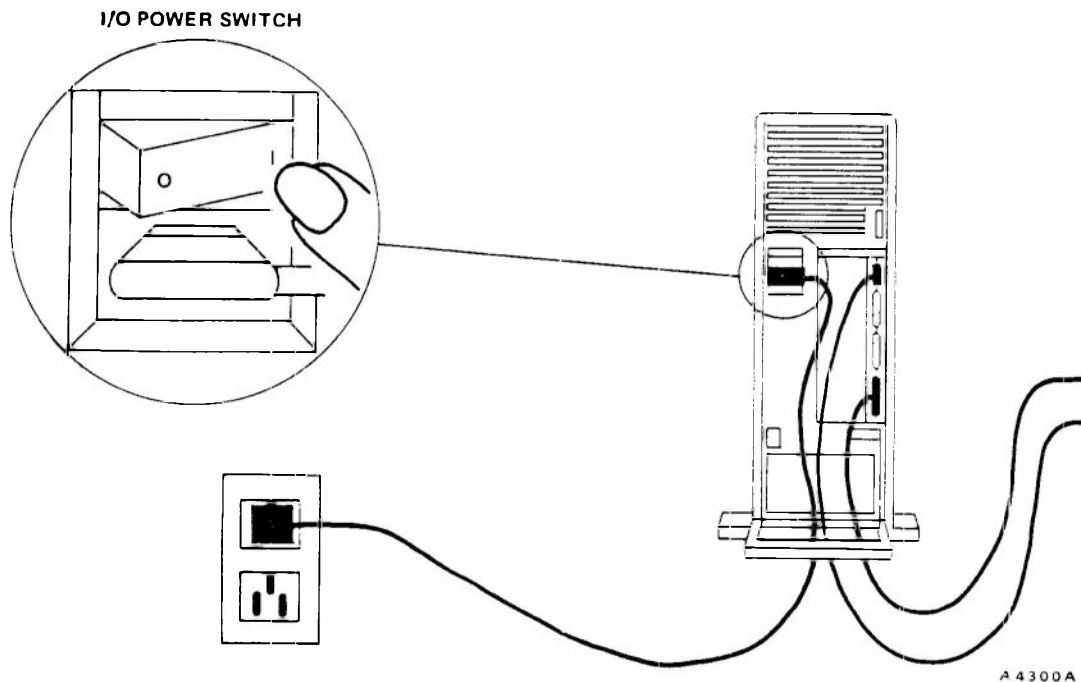

Turning on the Processing Unit's Power Switch

- 26 Next, turn on the terminal by pressing the terminal's power switch to ON while holding down the space bar on the keyboard; hold down the space bar until the lights on the keyboard go out. See the following figure.

NOTE: A problem exists if the lights on the keyboard do not go out; if the terminal does not turn on, or if an error message appears on your screen. Perform the following steps, in order, until you solve the problem:

- Check to see that the cable connections connecting the terminal to the power module and the connections connecting the power module to the electrical outlet are secure.
- Make sure that your electrical outlet is live by turning on any power switch that powers the electrical outlet.
- Turn off the TM6000 terminal for a few seconds then power it up again.
- If neither of the steps above solve your problem, call your Field Engineer for help.

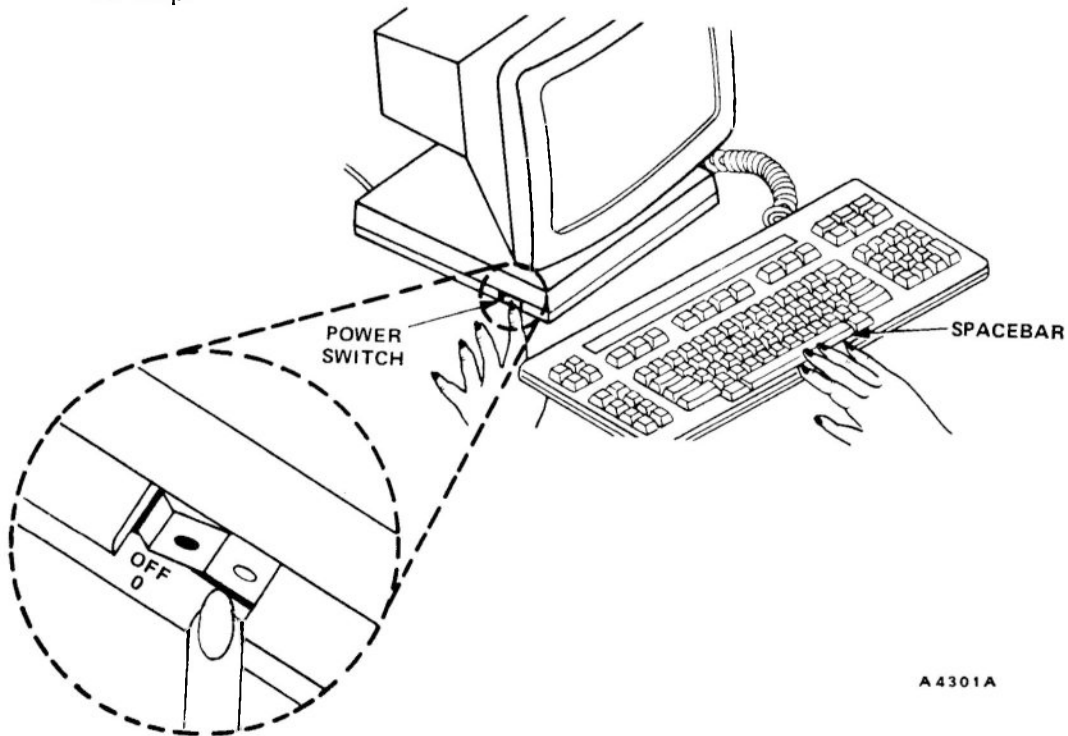

Turning on the Terminal's Power Switch

The following prompt appears on your terminal screen. (A prompt is a screen message usually requesting you to do something or telling you something is happening or will happen.)

V 1.0

Prompt: B,C,E,F,M,R,S,T:

- 27 Now that you have powered up your system for the first time, turn off the terminal by pressing the terminal's power switch off. See the following figure.

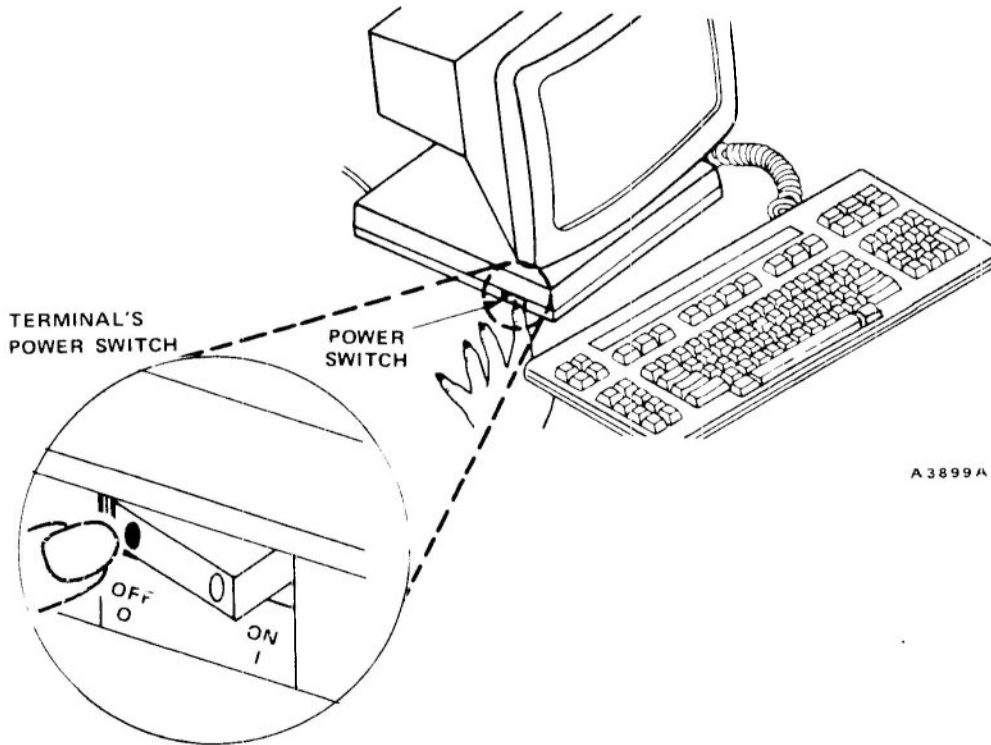

Turning Off the Terminal's Power Switch

- 28 Next, turn off the processing unit by pressing the processing unit's power switch to the "O" or OFF position. See the following figure.

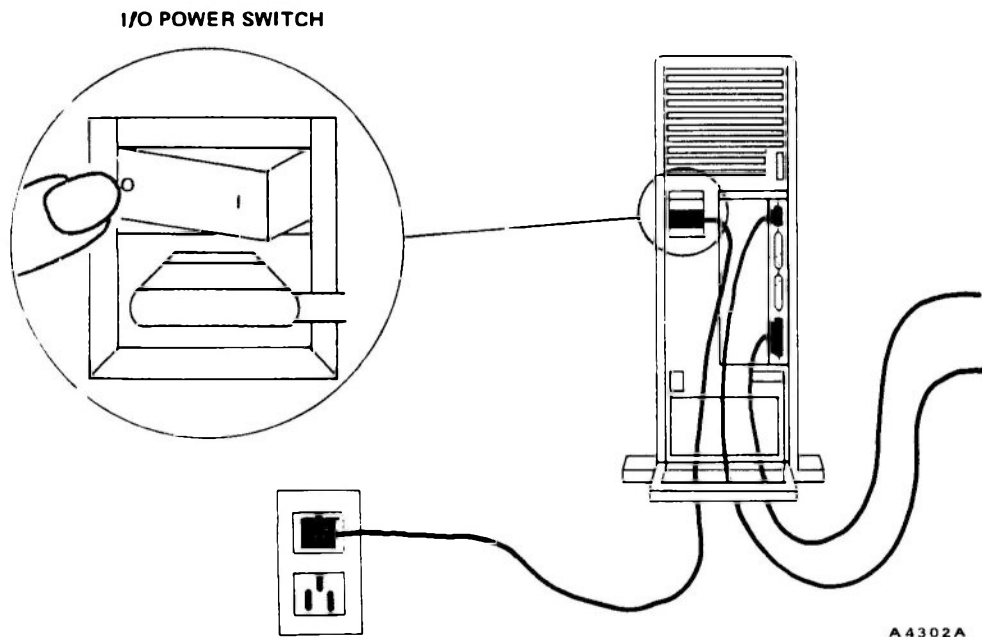

Turning Off the Processing Unit's Power Switch

Your system is now ready for software installation. Do not proceed in this manual until you have installed your software into your system. Consult *The System 6300 Software Installation Guide* for software installation instructions.

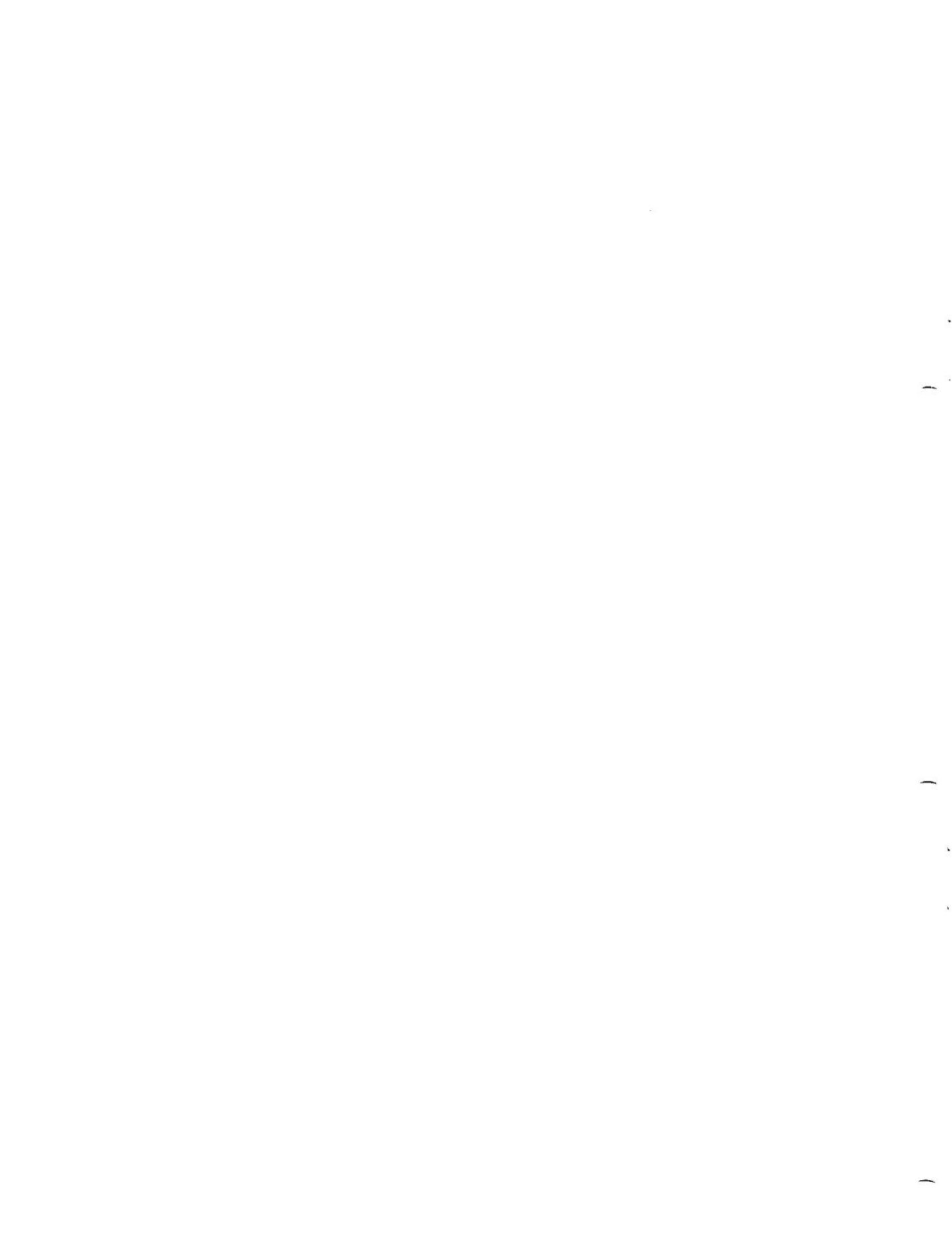

Section 3

Getting to Know Your System's Operating Mechanisms

- Identifying Components, Controls, Switches, and Indicators, 3-1
 - The Processing Unit, 3-1
 - The TM6000 Workstation, 3-2
- Loading and Unloading a Floppy Diskette, 3-3

Illustrations

- 3-1 Processing Unit's Switches and Indicators, 3-2
- 3-2 The TM6000 Workstation Components, Switches, and Controls, 3-3
- 3-3 Loading the Floppy Diskette, 3-4

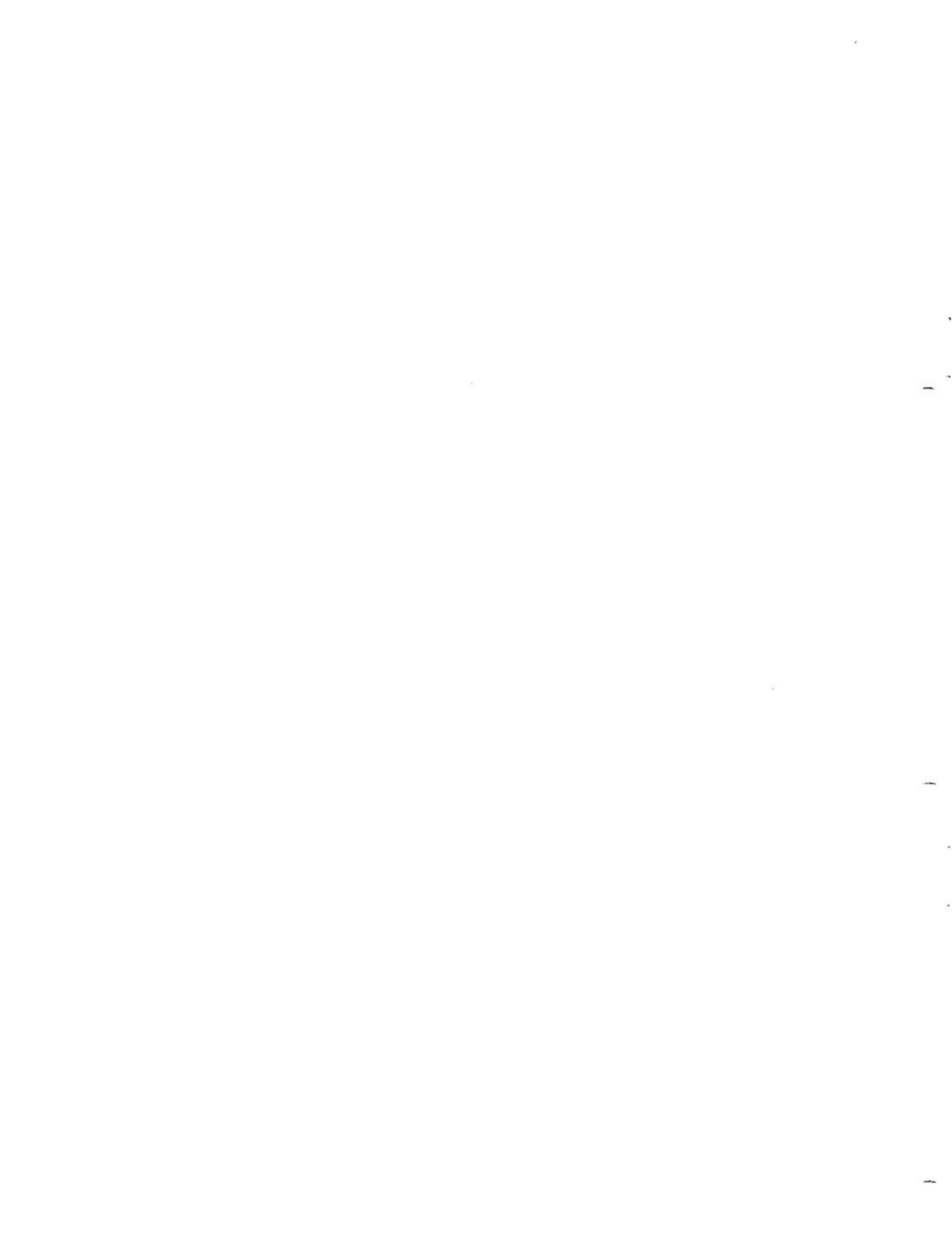

This section familiarizes you with the System 6300's various controls, switches, and indicators so that you may operate your system. This section shows you how to load and unload a floppy diskette in case you need to move data or software programs onto or off your system.

In this section we assume that the installation of the System 6300 hardware and the operating system software has already been completed. Because we assume the installation of the hardware has been completed, this section does not re-identify the system's cables and connectors. If you have to reconnect a loose connection, either go back to Section 2 for installation instructions or look at Appendix B of this manual to identify a particular connector and its function.

IDENTIFYING COMPONENTS, CONTROLS, SWITCHES, AND INDICATORS

The Processing Unit

The various switches, and indicators for the System 6300 processing unit, are located on the rear of the unit where the power-cord connector is located. See Figure 3-1.

The processing unit has the following switches and indicators:

- ***The I/O Switch (the ON/OFF switch):*** Use this switch to turn the processing unit's power on and off.
- ***The Status Indicators (also known as LEDs):*** These five indicators indicate the status of the processing unit as it goes through the "boot" procedure. (The boot procedure is that part of powering-up when the processing unit loads in its operating system.) The number 2 indicator lights when the processing unit is powered on.
- ***The RESET Switch:*** You enable this switch by pressing down until you hear it activate. Use this switch to restart the processing unit if it has been shut down. Also, you can use this switch to boot the processing unit, once you have gone through the initial power-up of the system.

NOTE: Also located on the lower left rear of the processing unit are the processing unit's power requirements. The processing unit's power requirements should match your electrical outlet's power output. If your unit's power requirements do not match your outlet's output, call your Field Engineer.

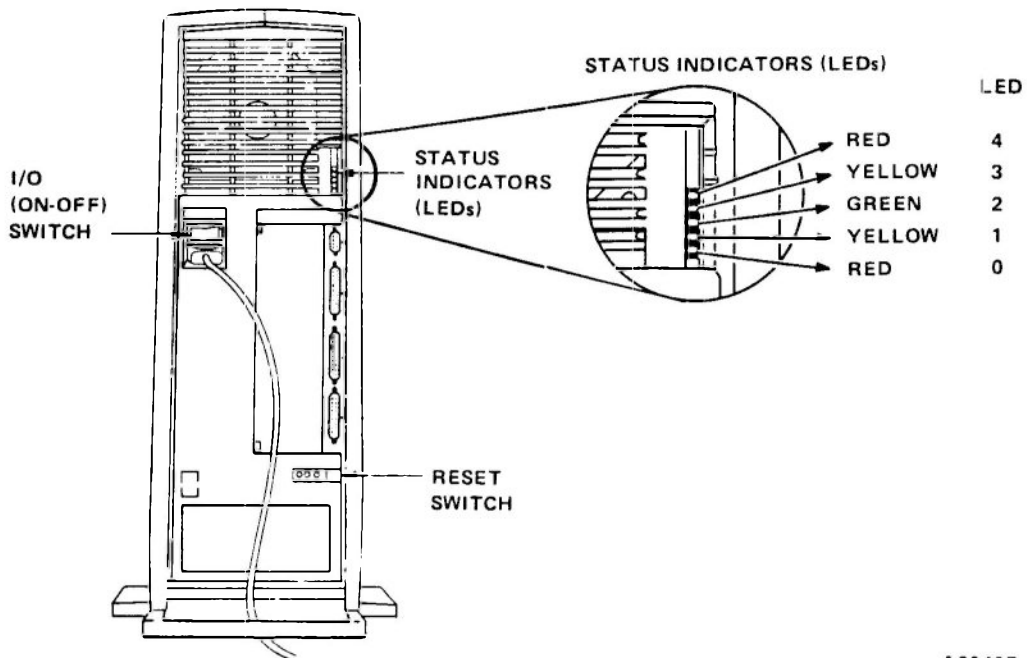

A 38 49B

Figure 3-1. Processing Unit's Switches and Indicators

The TM6000 Workstation

To operate the TM6000 workstation, you must become familiar with the following components, switches, and controls shown in Figure 3-2.

The TM6000 controls and switches have the following functions:

- **The Power Switch:** This switch turns on the power to the terminal. It is located on the left side of the video base assembly.
- **The Brightness Control:** Use this control wheel to control the brightness of your screen displays. This control wheel is located underneath the left side of the video display unit close to the power switch.
- **The Power Module's Voltage Selection Switch:** The voltage selection switch (located underneath the power module's black sticker that has the

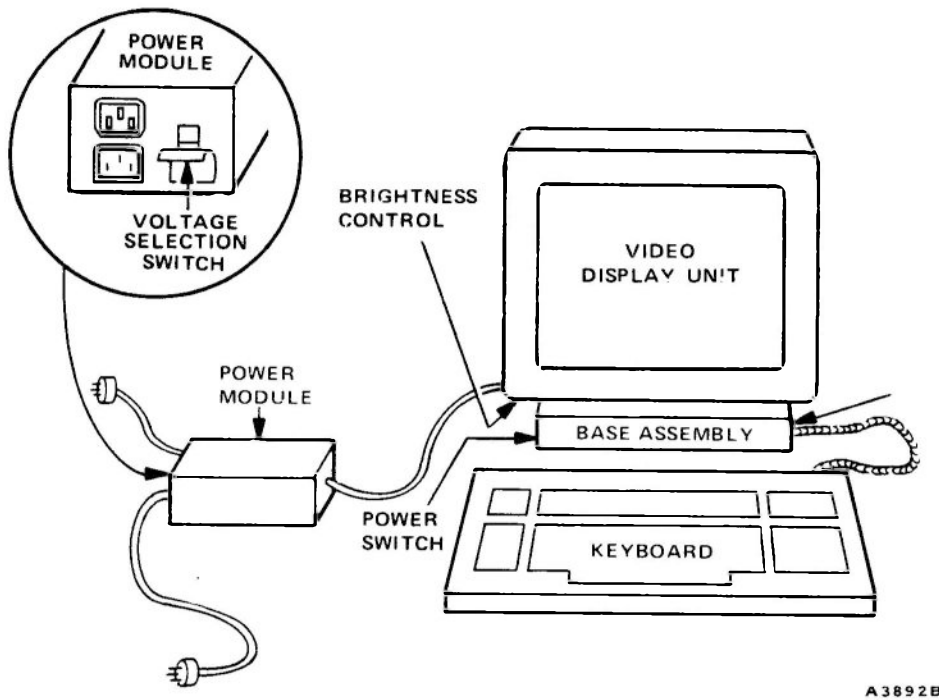

Figure 3-2. The TM6000 Workstation Components, Switches, and Controls

input/output information) converts from 115 input voltage to 220 input voltage to match the voltage coming from your electrical outlet. The black sticker indicates the input voltage that the switch is set at by the factory.

LOADING AND UNLOADING A FLOPPY DISKETTE

The floppy disc slot located on the upper front of the processing unit accepts the floppy diskettes, which contain the software for your system.

To load the diskettes perform the following procedure:

- 1 Power up the system.
- 2 Push open a small latch that fits over the disc slot. To open the latch, press with your thumb on the left side of the latch, as you face the disc slot. The latch then snaps open.

- 3 Next, insert the diskette with the oblong cutout on the diskette going into the disc slot first, with the small rounded cutout facing down. See Figure 3-3.
- 4 Finally, close the latch over the diskette. The indicator light below the floppy disc slot lights when the floppy is loaded correctly. See Figure 3-3.
- 5 To unload the floppy diskette merely open the latch and pull out the diskette.

CAUTION

Insert the diskette only after powering-up the system, and remove the diskette before powering-down the system, otherwise the data on your diskette could be destroyed.

Do not touch the diskette surface exposed by slots in the carrier envelope of the floppy diskette.

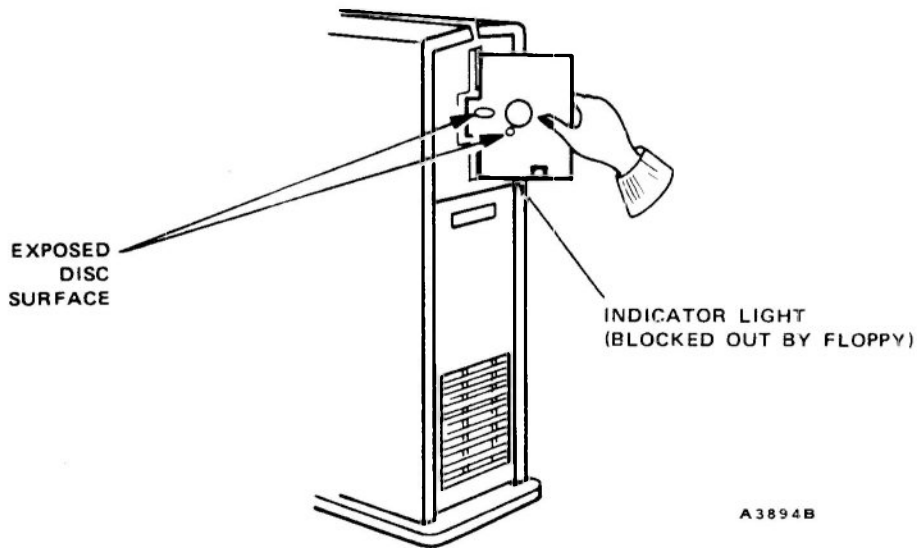

Figure 3-3. Loading the Floppy Diskette

You are now familiar with the System 6300's operating mechanisms. If you want to know how to bring up your system to get it ready to use, see your *System 6300 Software Installation Guide* for instructions.

Section 4

Maintenance and Care

- Maintaining a Proper Environment For the System 6300 Processing Unit, 4-1
- TM6000 Maintenance and Care, 4-1
 - Maintaining a proper environment, 4-1
 - Video Tilt and Swivel, 4-1
 - Cleaning the Terminal, 4-2
- Care of Floppy Diskettes, 4-2



The System 6300 processing unit and the TM6000 workstation require minimum maintenance to keep them operating properly. This section includes a description on the appropriate environment for the System 6300 processing unit, instructions on how to adjust and clean the TM6000 terminal, and procedures on how to prevent loss or damage of the floppy diskettes.

MAINTAINING A PROPER ENVIRONMENT FOR THE SYSTEM 6300 PROCESSING UNIT

The temperature range for operation of the processing unit is 50 to 104 degrees Fahrenheit (10 to 40 degrees Centigrade). The nonoperating temperature range is -40 to 140 degrees Fahrenheit (-40 to 60 degrees Centigrade). Make sure that the ventilation grilles are free from obstruction for proper ventilation; remember, a cooler system is more reliable.

The humidity range for the processing unit is 10 percent to 80 percent relative humidity while the system is operating and 5 percent to 95 percent relative humidity if the system is not operating.

TM6000 MAINTENANCE AND CARE

Maintenance and care for the TM6000 is minimal. Care of the workstation includes the following items:

Maintaining a Proper Environment

The temperature range for operation of the TM6000 workstation is 32 to 104 degrees Fahrenheit (0 to 40 degrees Centigrade). The nonoperating temperature range is -40 to 167 degrees Fahrenheit (-40 to 60 degrees Centigrade). As in the case of the processing unit, again make sure that the ventilation grilles of the TM6000 are free from obstruction for proper ventilation.

The humidity range for the TM6000 workstation is 5 to 95 percent noncondensing relative humidity while the workstation is operating.

Video Tilt and Swivel

The tilt and swivel action of the screen is preset at the factory. If there is excessive free play in the tilt and swivel action of your terminal screen, call your Field Engineer for help.

Cleaning the Terminal

If the video display screen needs cleaning, use a glass cleaner and a soft cloth. Abrasive cleaners can damage the anti-reflection coating on the screen surface. To prevent liquid from entering the display housing, spray the cleaner on the cloth and then wipe the screen.

If the plastic housing needs cleaning, use a damp, clean cloth and gently wipe the surfaces. Be careful not to get liquid into the keyboard.

CARE OF FLOPPY DISKETTES

To ensure that a backup copy is always available, copy the start-up floppy diskettes. Refer to the *System 6300 Software Installation Guide* for copying instructions.

Prevent loss of data or damage to floppy diskettes by storing them in a protected location having the following requirements:

- No direct sunlight.
- Temperature range from 50 to 125 degrees Fahrenheit (0 to 40 degrees Centigrade) or as stated on the diskette, which may vary from one manufacturer to another.
- Relative humidity range from 8 to 80 percent noncondensing.
- No sources of magnetization.
- No dust.

If you want to order floppy diskettes from Four-Phase Systems, call IV Supplies at either one of the following numbers:

- If you are located in California in the 408 area code, call (408) 252-8114.
- If you are located in California outside the 408 area code, call toll free (800) 221-6878.
- If you are located in the United States outside of California, call toll free (800) 221-6880.

Appendix A

The Processing Unit and TM6000 Specifications

Processing Unit Specifications, A-1
TM6000 Workstation Specifications, A-2

Tables

- A-1 Dimensions and Weight of the 6300 Processing Unit, A-1
- A-2 Power Requirements for the 6300 Processing Unit, A-1
- A-3 Environmental Specifications for the 6300 Processing Unit, A-2
- A-4 TM6000 Workstation Specifications, A-2



PROCESSING UNIT SPECIFICATIONS

The following Tables A-1, A-2, and A-3 give the processing unit specifications:

Table A-1. Dimensions and Weight of the 6300 Processing Unit

Height	22.5 inches (571.5mm)
Width	7.0 inches (177.8mm) including base 30.5 inches (774.7mm) opened
Depth	23.0 inches (585.2mm) including rear 2-inch standoff
Weight	60 pounds (27.5 kilos)

Table A-2. Power Requirements for the 6300 Processing Unit

Condition	Requirement
Input Voltage	110VAC Nominal (85 to 130V RMS) 220VAC Nominal (200 to 260V RMS)
Input Frequency	50/60 Hz Nominal (47 to 63 Hz continuous)
Surge Current	115VAC: 20 Amps (for two cycles) 220VAC: 10 Amps (for two cycles)
Operating Current	115VAC: 2.6 Amps maximum (230 Watts) 220VAC: 1.3 Amps maximum (230 Watts)
Heat Production	Maximum 1018 Btu/hr, Average 444 Btu/hr

Table A-3. Environmental Specifications for the 6300 Processing Unit

Condition	Status	Limit
Temperature	Operating	50°F to 104°F (10°C to 40°C) (full load, convection cooled)
	Nonoperating	-40°F to 140°F (-40°C to 60°C)
Humidity	Operating	10% to 80% RH
	Nonoperating	5% to 95% RH (noncondensing)
Altitude	Operating	Sea level to 10,000 feet (3048m)
	Nonoperating	Sea level to 30,000 feet (9144m)

TM6000 Workstation Specifications

Table A-4 lists the TM6000 workstation specifications.

Table A-4. TM6000 Workstation Specifications

Dimensions	
Video Display	Keyboard
Width: 12.4 in. (31.6 cm)	Width: 18.0 in. (45.7 cm)
Height: 11.9 in. (30.2 cm)	Height: 1.2 in. (3.3 cm)
Depth: 11.6 in. (29.5 cm)	Depth: 7.9 in. (19.7 cm)
Power Requirements	
115 VAC at 47 to 63 Hz, 1 amp, (domestic requirements)	
220 VAC at 47 to 63 Hz, .5 amp, (foreign requirements)	
Environmental Specifications	
Operating Temperature	32°F to 104°F (0°C to 40°C)
Nonoperating Temperature	-40°F to 140°F (-40°C to 60°C)
Relative Humidity	5% to 95% noncondensing
Heat Production	Maximum 205 BTU/hr. Average 137

Appendix B

The Processing Unit and TM6000 Connectors

The Processing Unit Connectors, B-1
TM6000 Workstation Connectors, B-2

Illustrations

- B-1 Rear View of the System 6300 Processing Unit, B-1
- B-2 TM6000 Workstation Keyboard Connectors, B-2
- B-3 TM6000 Workstation (Rear View), B-3
- B-4 Power Module Connectors and Switch, B-4

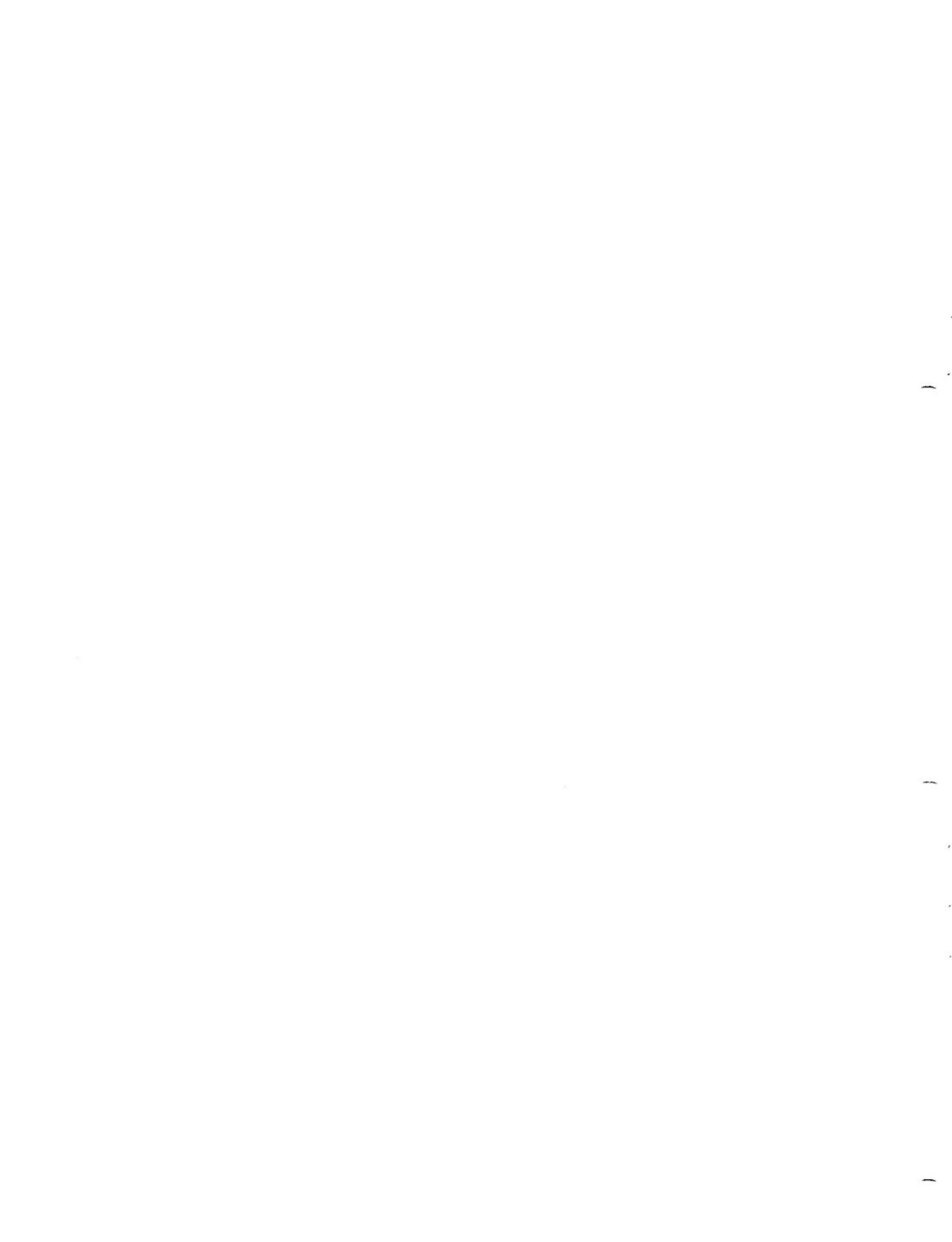

“Connectors” are plug- or socket-like devices where you insert cords or cables to make a connection, usually between two units. Following are listings and descriptions of the connectors for the System 6300 processing unit and the TM6000 workstation. If you have problems with other definitions in this section, see the glossary at the end of this manual.

THE PROCESSING UNIT CONNECTORS

The various connectors for the System 6300 processing unit are located on the rear of the unit where the power-cord connector is located. See Figure B-1.

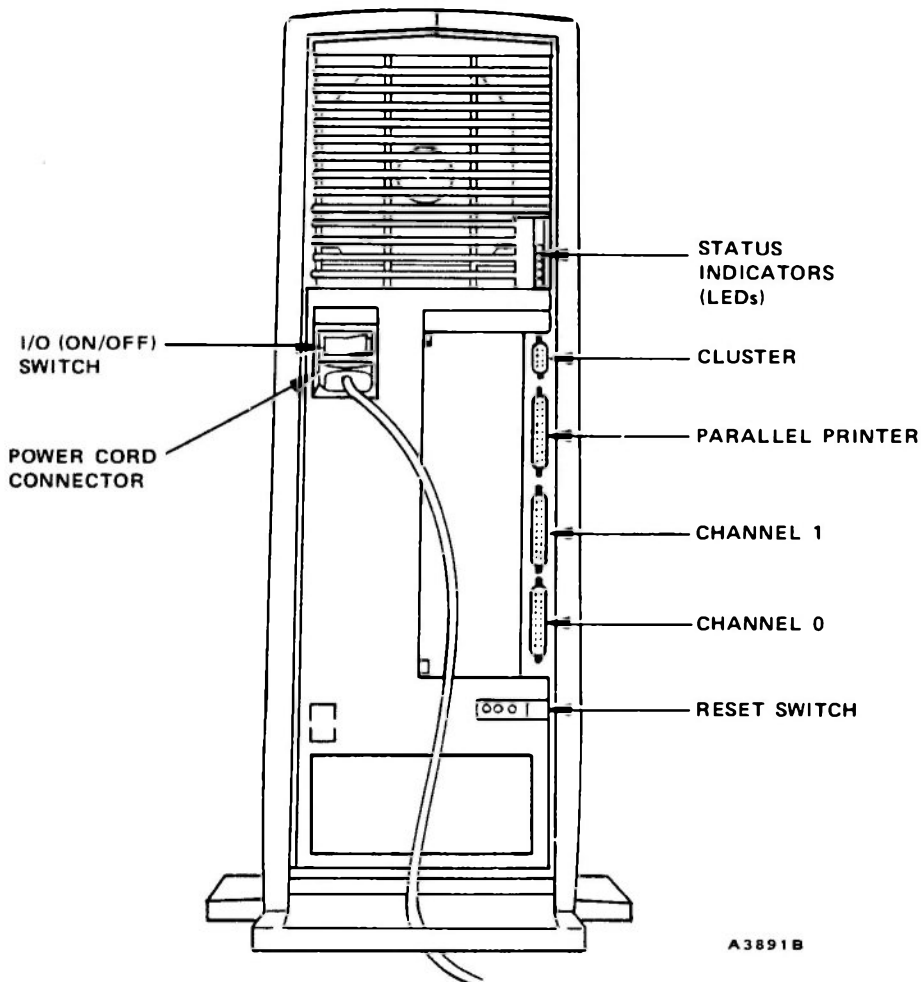

Figure B-1. Rear View of the System 6300 Processing Unit

This rear area of the processing unit has the following connectors:

- **The Parallel Printer Connector:** This connector connects parallel printers into the System 6300 processing unit.
- **The Cluster Connector:** Use this connector to hook up the processing unit to a terminal with the RS-422 cable.
- **The Channel 1 Connector:** This connector hooks up serial printers, terminals, or communication devices into the System 6300 processing unit.
- **The Channel 0 Connector:** This connector connects only the first terminal to the processing unit. An RS-232 Cross cable makes this connection.
- **The Power Cord Connector:** This connector plugs in the processing unit's power cord to your electrical outlet.

THE TM6000 WORKSTATION CONNECTORS

As you face the front of the TM6000 workstation, you have a connector labeled "keyboard" on the right side of the base assembly that connects the keyboard to the video display unit with the coiled cable. You connect the other end of the coiled cable to either of the two connectors on the rear of the keyboard. See Figure B-2 for location of the keyboard connectors.

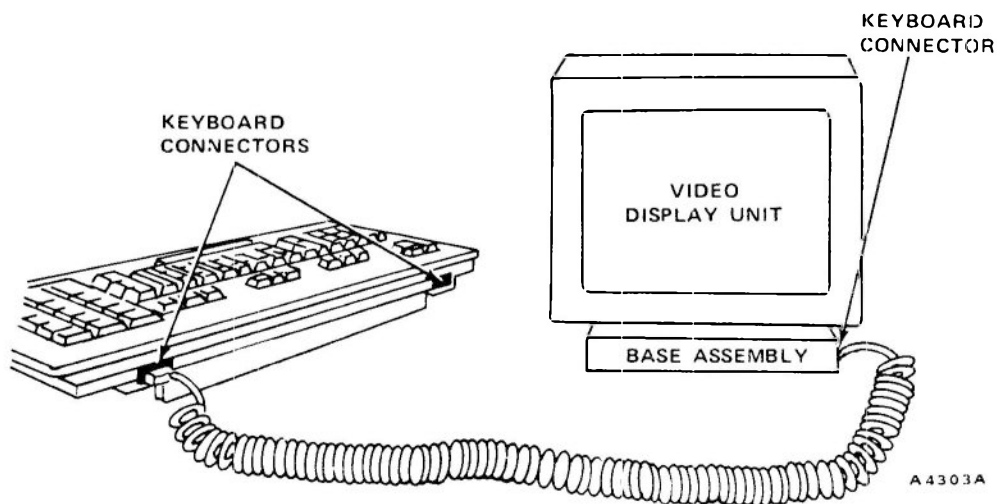

Figure B-2. TM6000 Workstation Keyboard Connectors

As you face the rear of the TM6000 workstation you have the following connectors: (See Figure B-3)

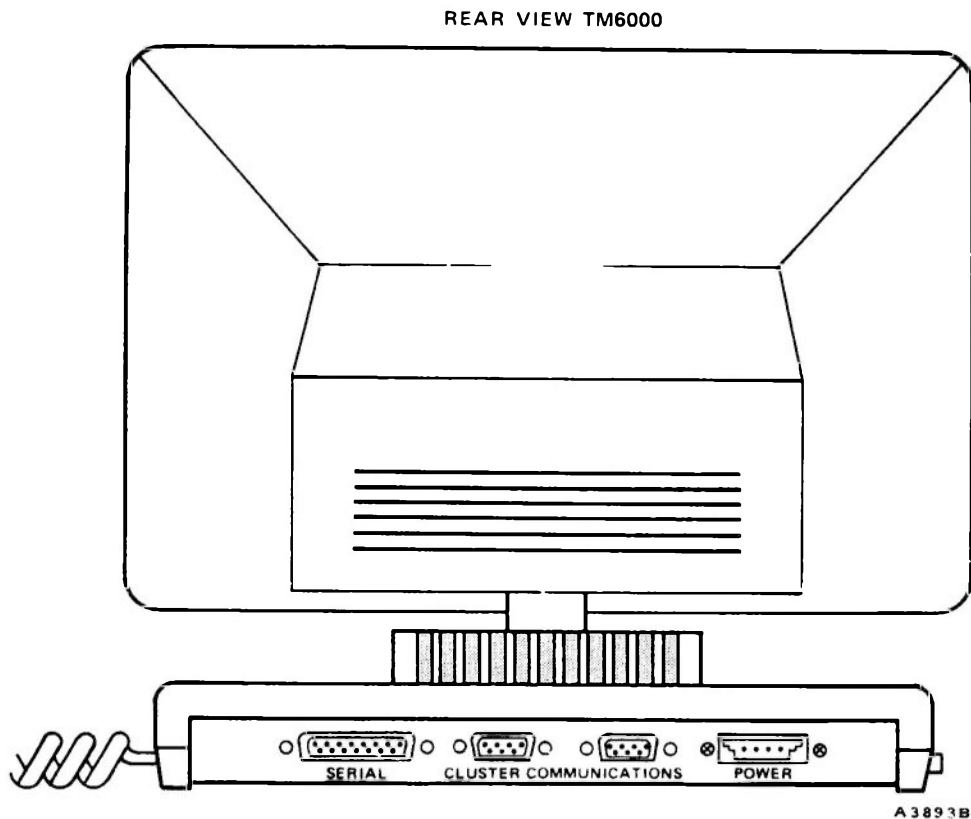
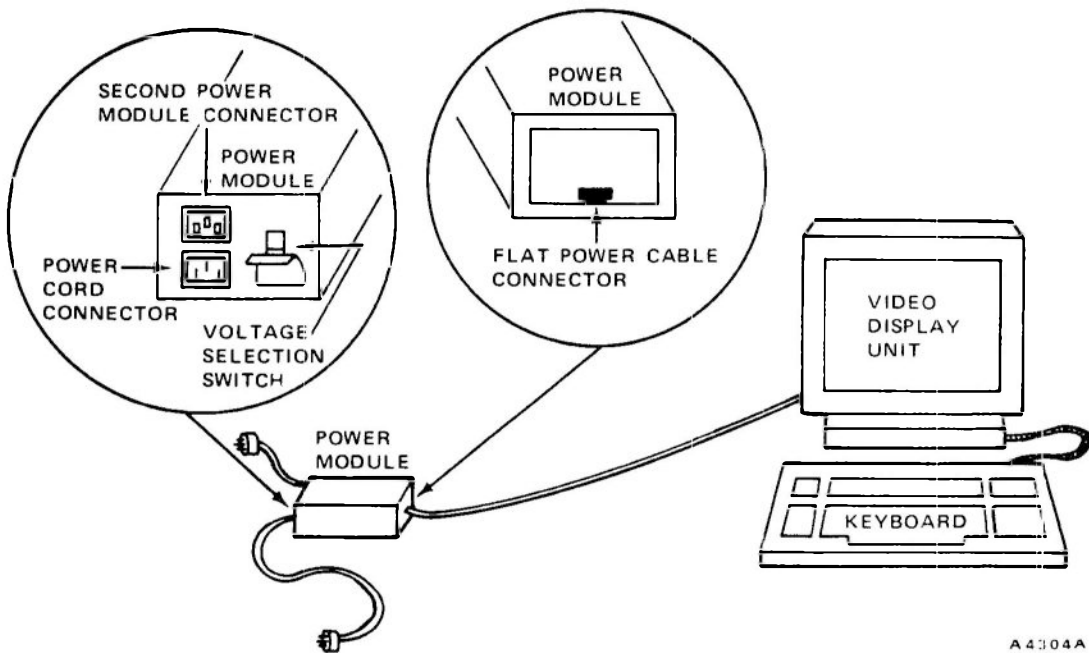

Figure B-3. TM6000 Workstation (Rear View)

- **The Serial Connector:** This connector connects only the first TM6000 terminal to the processing unit. This connection is made with an RS-232 Cross cable.
- **The Cluster Communications Connectors:** These connectors connect the TM6000 workstation to the processing unit with the RS-422 cable. These connectors also connect one TM6000 workstation to another when you are trying to hook up a series, or cluster, of terminals.
- **The Power Cable Connector:** This is the connector that connects the terminal to your power module.

The power module, which is part of the TM6000 workstation, has the following connectors. See Figure B-4.



A4304A

Figure B-4. Power Module Connectors and Switch

- **The Flat Power Cable Connector:** This is the connector where you plug in the flat power cable that comes from the power cable connector on the terminal.
- **The Power Cord Connector:** Use this connector to plug in the longer of the two power cords. The other end of this power cord plugs into your electrical outlet to give power to your terminal.
- **The Second Power Module Connector:** This connector connects the shorter power cord to a second power module. You would need a second power module if you added a second terminal to your system. You need a power module for every terminal added to your system.

Glossary

Boot. To boot the system means to activate the software program that starts your unit. The boot procedure is part of the power-up procedure of both the TM6000 terminal workstation and the processing unit.

Bring up. Bringing up your system means to start your system. To get it ready for use, you must also type in answers to all the questions that appear on your screen. Instructions on how to bring up and bring down (or shutdown) your system are found in your *System 6300 Software Installation Guide*.

Cables. Cables are the wiring that connects one unit to another.

Configuration. A configuration is a particular set-up of the System 6300. For example, your system can be configured to have one or several TM6000 workstations, and it can be configured to have 1/2 megabyte of memory or 2 megabytes of memory.

Connectors. Connectors are sockets that hook up a cord or cable to make a connection, generally between two or more units.

Cursor. A cursor is the blinking marker on the video display screen that indicates your position on the screen. It shows where you stopped writing and where you will start writing.

Diskette. A diskette, also called a "floppy," looks like a small music record in a dust jacket. Part of the procedure to load or unload software is to insert the diskette that contains the software into the disc drive mechanism.

Floppy Disc Drive. You load the diskette into the floppy disc drive.

Intelligent Terminal. An intelligent terminal can perform certain functions by itself. In other words, the terminal does not have to rely on the processing unit's software to perform all the terminal's functions.

Megabyte. A megabyte, as in 1 megabyte of memory, is one million bytes of memory. A byte is eight bits, or how many bits of memory it takes to accommodate one number, character, or punctuation mark in the processing unit.

- On a scale of 1 to 10, how do you rate this manual?

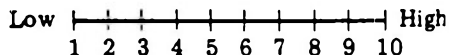

- Was this manual difficult to obtain? Yes No
- What is your occupation?

- | | | |
|--|-------------------------------------|--|
| <input type="checkbox"/> Programmer | <input type="checkbox"/> Operator | <input type="checkbox"/> Manager |
| <input type="checkbox"/> Systems Analyst | <input type="checkbox"/> Instructor | <input type="checkbox"/> Customer Engineer |
| <input type="checkbox"/> Engineer | <input type="checkbox"/> Student | <input type="checkbox"/> Other _____ |

- How do you use this manual?

- | | |
|---|--|
| <input type="checkbox"/> Reference Manual | <input type="checkbox"/> Introduction to the Subject |
| <input type="checkbox"/> In a Class | <input type="checkbox"/> Introduction to the System |
| <input type="checkbox"/> Self Study | <input type="checkbox"/> Other _____ |

Help us help you! Please take the time to complete this form and send it to us. If you do, you may see some of your own contributions in the next manual you obtain from us.

MOTOROLA INC.
10700 North De Anza Blvd.
Cupertino, CA 95014

Attention: CSO Publications, MS 42-8G3

Please include your name and address if you would like a reply.

Name _____

Company _____

Address _____

System 6300 Hardware
Installation and User's Guide



MOTOROLA
Information Systems

87601199A