

**MicroVAX 3900  
VAXserver 3900  
Operation**

Order Number EK-168AA-OM-001

**digital equipment corporation  
maynard, massachusetts**

---

March 1989

The information in this document is subject to change without notice and should not be construed as a commitment by Digital Equipment Corporation.

Digital Equipment Corporation assumes no responsibility for any errors that may appear in this document.

The software, if any, described in this document is furnished under a license and may be used or copied only in accordance with the terms of such license. No responsibility is assumed for the use or reliability of software or equipment that is not supplied by Digital Equipment Corporation or its affiliated companies.

---

© Digital Equipment Corporation 1989. All rights reserved.

Printed in U.S.A.

---

The **READER'S COMMENTS** form on the last page of this document requests the user's critical evaluation to assist in preparing future documentation.

The following are trademarks of Digital Equipment Corporation:

COMPACTape	DIBOL	RSX
DDCMP	DSSI	RT
DEC	MASSBUS	ThinWire
DECmate	MicroVAX	ULTRIX
DECnet	PDP	UNIBUS
DECserver	P/OS	VAX
DECUS	Professional	VAXcluster
DECwriter	Q-bus	VAXELN
DELNI	Rainbow	VAXlab
DELQA	ReGIS	VMS
DEQNA	RQDX	VT
DESTA	RSTS	Work Processor

**digital**<sup>™</sup>

ML-S936

**FCC NOTICE:** The equipment described in this manual generates, uses, and may emit radio frequency energy. The equipment has been type tested and found to comply with the limits for a Class A computing device pursuant to Subpart J of Part 15 of FCC Rules, which are designed to provide reasonable protection against such radio frequency interference when operated in a commercial environment. Operation of this equipment in a residential area may cause interference, in which case the user at his own expense may be required to take measures to correct the interference.

This document was prepared using VAX DOCUMENT, Version 1.1.

---

# Contents

---

<b>Preface</b>	<b>ix</b>
----------------	-----------

---

## **Chapter 1 System Overview**

---

<b>1.1 Front View of the MicroVAX/VAXserver 3900</b>	<b>1-4</b>
<b>1.1.1 The BA213 Chassis</b>	<b>1-10</b>
<b>1.1.1.1 Mass Storage Shelf</b>	<b>1-11</b>
<b>1.1.1.2 Card Cage</b>	<b>1-12</b>
<b>1.1.1.3 Power Supplies</b>	<b>1-16</b>
<b>1.1.1.4 Fans</b>	<b>1-18</b>
<b>1.1.2 Mass Storage Options</b>	<b>1-20</b>
<b>1.2 Rear View of the MicroVAX/VAXserver 3900</b>	<b>1-20</b>
<b>1.2.1 Power Controller</b>	<b>1-22</b>
<b>1.3 Functional Description of Base System</b>	<b>1-24</b>
<b>1.3.1 Base System Components</b>	<b>1-24</b>
<b>1.3.1.1 Central Processing Unit (CPU)</b>	<b>1-25</b>
<b>1.3.1.2 Console Serial Line Unit (SLU)</b>	<b>1-25</b>
<b>1.3.1.3 Main Memory</b>	<b>1-25</b>
<b>1.3.1.4 Network Controller</b>	<b>1-25</b>
<b>1.3.1.5 Mass Storage Devices and Controllers</b>	<b>1-25</b>
<b>1.3.2 Optional Components</b>	<b>1-26</b>
<b>1.3.2.1 Communications Controllers</b>	<b>1-26</b>
<b>1.3.2.2 Real-Time Controllers</b>	<b>1-28</b>
<b>1.3.2.3 Printer Interfaces</b>	<b>1-28</b>
<b>1.3.2.4 Other Available Options</b>	<b>1-28</b>

## Chapter 2 Operating the System

---

2.1	Before You Operate the System .....	2-1
2.2	Switch Settings .....	2-1
2.2.1	Normal Operation .....	2-1
2.2.2	Special Operation .....	2-2
2.3	Turning On the System .....	2-4
2.4	Booting the System .....	2-5
2.4.1	Autobooting the System .....	2-5
2.4.2	Booting the System from Console Mode .....	2-8
2.5	Using the System .....	2-9
2.6	Turning Off the System .....	2-10
2.7	Halting the System .....	2-10
2.8	Restarting the System .....	2-11

## Chapter 3 Operating System Options

---

3.1	Mass Storage Options .....	3-1
3.1.1	RA-Series Disk Drives .....	3-1
3.1.1.1	RA90 Controls and Indicators .....	3-2
3.1.1.2	RA60/70/82 Drive Controls and Indicators .....	3-6
3.1.1.3	RA60 Disk Pack .....	3-9
3.1.1.4	Replacing an RA82 Air Filter .....	3-12
3.1.2	TK70 Tape Drive .....	3-13
3.1.2.1	Design of the Drive .....	3-15
3.1.2.2	Labeling a Tape Cartridge .....	3-16
3.1.2.3	Write-Protecting a Tape Cartridge .....	3-17
3.1.2.4	Tape Cartridge Handling and Storage Guidelines .....	3-19
3.1.2.5	Inserting a Tape Cartridge .....	3-20
3.1.2.6	Removing a Tape Cartridge .....	3-22
3.1.2.7	Summary of TK70 Tape Drive Controls and Indicator Lights .....	3-24
3.1.3	TSV05 Tape Drive .....	3-25
3.1.3.1	Controls and Indicators .....	3-25
3.1.3.2	Inserting Write-Enable Ring .....	3-26
3.1.3.3	Loading Tape .....	3-27
3.1.3.4	Rewinding Tape .....	3-28



3.1.3.5	Unloading Tape .....	3-29
3.1.3.6	Restarting the Tape Drive .....	3-29
3.1.3.7	Care of Magnetic Tapes .....	3-29
3.1.4	TU81-Plus Tape Drive .....	3-31
3.1.4.1	Controls and Indicators .....	3-31
3.1.4.2	Inserting Write-Enable Ring .....	3-33
3.1.4.3	Tape Threading and Loading .....	3-34
3.1.4.4	Tape Unloading .....	3-37
3.1.4.5	Fault Codes Corrective Actions .....	3-37
3.2	Communications Controller Options .....	3-38
3.2.1	Asynchronous Serial Controllers .....	3-38
3.2.1.1	Without Modem Support .....	3-38
3.2.1.2	With Modem Support .....	3-40
3.2.2	Synchronous Controllers .....	3-41
3.2.3	Network Controllers .....	3-41
3.3	Real-Time Options .....	3-42
3.4	Printer Options .....	3-43
3.5	Adding Options .....	3-43

## Appendix A Related Documentation

---

### Glossary

---

### Index

---

### Figures

---

1-1	MicroVAX/VAXserver 3900 System with TU81-Plus Tape Drive .....	1-2
1-2	Expanded MicroVAX/VAXserver 3900 System .....	1-3
1-3	MicroVAX/VAXserver 3900 Cabinet .....	1-4
1-4	Key Positions .....	1-5
1-5	Sliding Window Closed .....	1-6
1-6	Window Partially Open .....	1-7

1-7	Window Fully Open .....	1-8
1-8	Opening the Front Door .....	1-9
1-9	Internal View of MicroVAX/VAXserver 3900 Cabinet .....	1-10
1-10	Mass Storage Shelf .....	1-11
1-11	Card Cage .....	1-13
1-12	CPU Cover Panel .....	1-15
1-13	Power Supply .....	1-17
1-14	System Air Circulation .....	1-19
1-15	Removing the Rear Panel .....	1-21
1-16	Rear View of MicroVAX 3900/VAXserver 3900 Cabinet .....	1-22
1-17	Power Controller .....	1-23
2-1	Language Selection Menu .....	2-3
2-2	Sample Error Summary .....	2-5
2-3	Successful Power-On and Automatic Boot .....	2-6
2-4	Successful Power-On to List of Bootable Devices .....	2-7
2-5	Successful Power-On to Console Mode .....	2-9
3-1	RA90 Fixed Disk Drive Controls .....	3-3
3-2	RA90 Unit Address Selection Flowchart .....	3-6
3-3	Location of RA70 Drive Controls .....	3-7
3-4	Opening the RA60 Disk Drive .....	3-10
3-5	Removing Bottom Dust Cover from an RA60 Disk Pack .....	3-11
3-6	RA82 Air Filter Removal .....	3-13
3-7	TK70 Tape Drive .....	3-15
3-8	Labeling a Tape Cartridge .....	3-16
3-9	Tape Cartridge Write-Protect Switch .....	3-18
3-10	Inserting a Tape Cartridge .....	3-21
3-11	Removing a Tape Cartridge .....	3-23
3-12	TSV05 Tape Drive Controls and Indicators .....	3-25
3-13	Inserting Write-Enable Ring (TSV05 Tape Reel) .....	3-27
3-14	Loading the TSV05 Tape Drive .....	3-28
3-15	TU81-Plus Tape Drive Controls and Indicators .....	3-31
3-16	Inserting Write-Enable Ring (TU81 Tape Reel) .....	3-33
3-17	Opening the TU81-Plus Cover .....	3-34
3-18	TU81-Plus Tape Deck .....	3-35
3-19	Tape Path .....	3-36

## Tables

---

2-1	Normal Power-On Indications .....	2-4
2-2	Device Names .....	2-8
3-1	RA90 Disk Drive Controls and Indicators .....	3-4
3-2	RA-Series Drive Controls and Indicators .....	3-8
3-3	TK70 Tape Drive Controls .....	3-24
3-4	TK70 Tape Drive Indicator Lights .....	3-24
3-5	TSV05 Tape Drive Controls and Indicators .....	3-26
3-6	TU81-Plus Tape Drive Operator Controls and Indicators ...	3-32
3-7	TU81-Plus Fault Codes and Corrective Actions .....	3-37

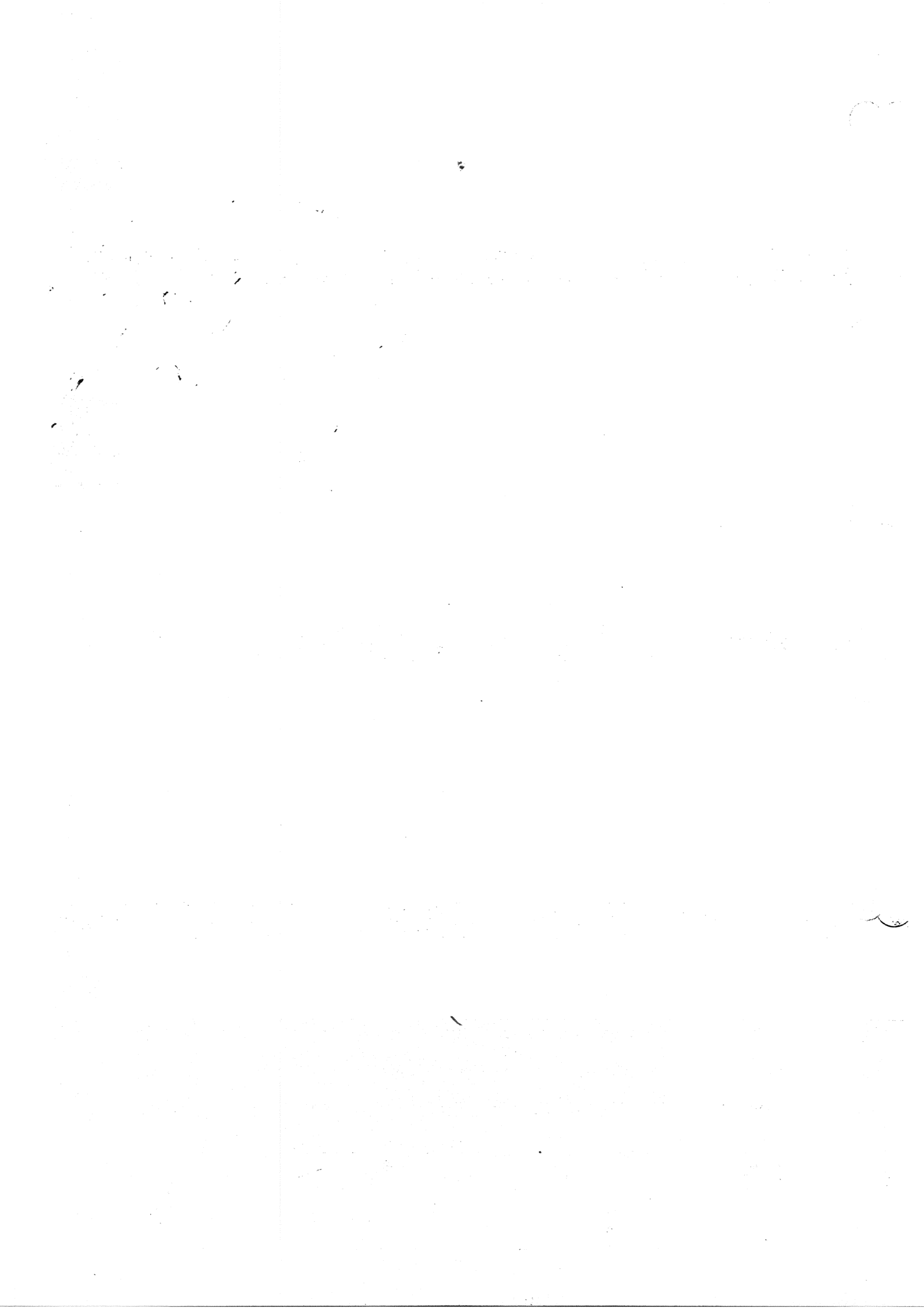

## Preface

---

This manual describes how to use MicroVAX 3900 and VAXserver 3900 systems. The hardware and software for each of these systems differs slightly, according to the function of the system. The MicroVAX 3900 is a multiuser system that uses the VMS, ULTRIX, or VAXELN operating system, and functions as an end- or full-function node on an Ethernet network. VAXserver systems are single-user systems that use either VMS or ULTRIX operating systems. VAXserver systems that use VMS are DECnet full-function network nodes; systems that use ULTRIX are DECnet end-function nodes.

The manual is structured as follows:

- Chapter 1 provides an overview of the systems.
- Chapter 2 describes how to use the systems.
- Chapter 3 describes how to use options installed in the systems.
- Appendix A lists related documentation.
- A glossary explains key terms.

**NOTE:** *VAXserver 3900 systems are designed to offer maximum performance for applications that do not require timesharing. Some of the devices referred to in this manual are designed for multiuser systems and may not be suitable for a VAXserver system. Contact your DIGITAL representative if you have any questions about whether use of a specific device is appropriate for your VAXserver system.*

## Conventions

The following conventions are used in this manual:

Convention	Meaning
<b>Key</b>	A symbol denoting a terminal key used in text and examples in this book. For example, <b>Break</b> indicates that you press the Break key on your terminal keypad. <b>Return</b> indicates that you press the Return key on your terminal keypad.
<b>Ctrl/C</b>	A symbol indicating that you hold down the Ctrl key while you press the C key.
<b>Bold</b>	Bold type is used to indicate user input. For example: <b>&gt;&gt;&gt;BOOT MUA0</b> This line shows that the user must type BOOT MUA0 at the ">>>" prompt.
<b>NOTE</b>	Provides general information about the current topic.
<b>CAUTION</b>	Provides information to prevent damage to equipment or software.
<b>WARNING</b>	Provides information to prevent personal injury.

## Chapter 1

# System Overview

---

MicroVAX 3900 and VAXserver 3900 systems have identical H9644 cabinets that house primary system components. At the top of the cabinet are one or two RA90 disk drives. Below the RA90(s) and behind a front door that limits access to system controls is a BA213 chassis, which houses the following:

- Central processing unit (CPU)
- Memory module(s)
- Communications controllers
- Mass storage controllers
- RA70 fixed-disk drive(s)
- TK70 tape drive
- Power supplies

Because the single cabinet is the basis of all MicroVAX 3900 or VAXserver 3900 systems described in this manual, this cabinet is referred to as the system cabinet throughout the manual. Sections 1.1 and 1.2 describe the system cabinet in more detail.

Both the MicroVAX 3900 and VAXserver 3900 can have auxiliary cabinets to hold additional mass storage devices. The following mass storage devices can be mounted in auxiliary cabinets:

- RA60 disk drive
- RA82 disk drive
- RA90 disk drive
- TSV05 tape drive
- TU81-Plus tape drive

Figure 1-1 shows a MicroVAX or VAXserver 3900 system cabinet with an auxiliary cabinet housing a TU81-Plus tape drive.

**Figure 1-1: MicroVAX/VAXserver 3900 System with TU81-Plus Tape Drive**

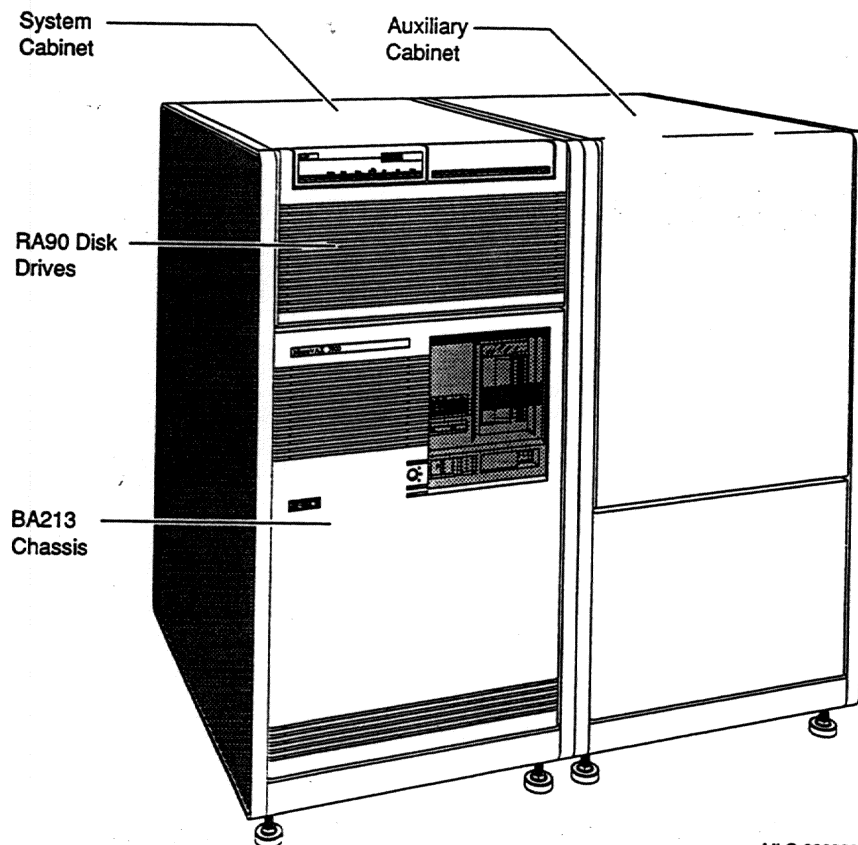

MLO-002298

MicroVAX and VAXserver 3900 systems can be ordered with the H9644 expander. The H9644 expander allows you to expand the Q-bus of a host MicroVAX or VAXserver 3900 system to 22 usable Q-bus slots. The H9644 also expands mass storage capacity by providing a second KDA50 controller and room for up to two RA90 fixed-disk drives and up to two RA70 fixed-disk drives. MicroVAX or VAXserver 3900 systems expanded with the H9644 can have a combined (MicroVAX or VAXserver 3900 and H9644) total of up to eight RA-series disk drives, four for each KDA50 controller.

Figure 1-2 shows an expanded MicroVAX or VAXserver 3900 system. The expanded system includes the system cabinet, the H9644 expander, and the TU81-Plus tape drive in its cabinet.

## 1-2 MicroVAX 3900 VAXserver 3900 Operation



**Figure 1-2: Expanded MicroVAX/VAXserver 3900 System**

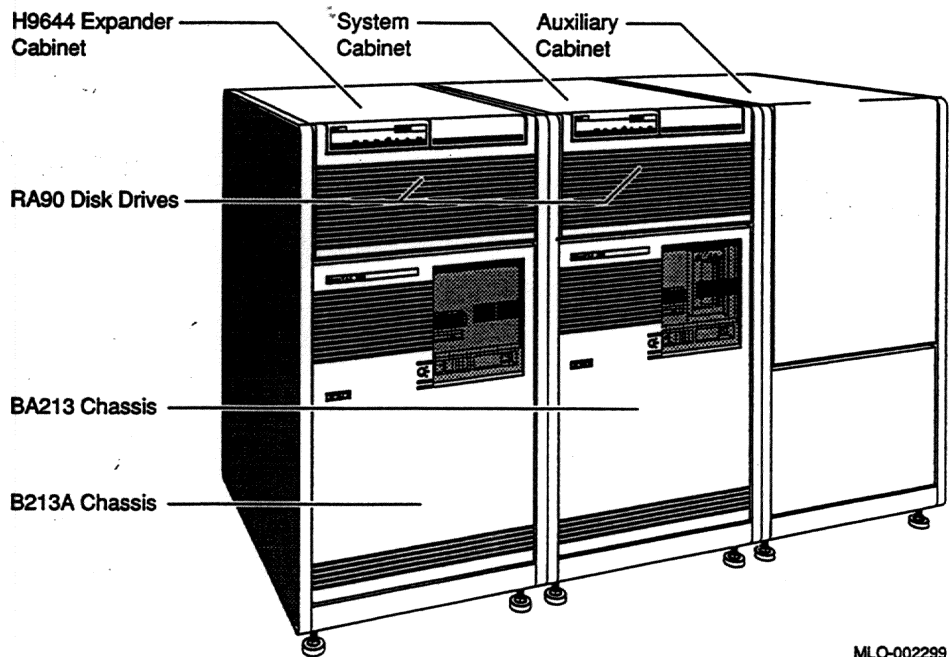

MLO-002299

**This chapter describes the MicroVAX or VAXserver 3900 system cabinet and the components it contains. The cabinet door, the BA213 chassis behind the door, and the function of the base system components are described in turn.**

**Chapters 2 and 3 describe how to use the system and options.**

## 1.1 Front View of the MicroVAX/VAXserver 3900

Figure 1-3 shows the MicroVAX/VAXserver 3900 cabinet with the front door closed.

Figure 1-3: MicroVAX/VAXserver 3900 Cabinet

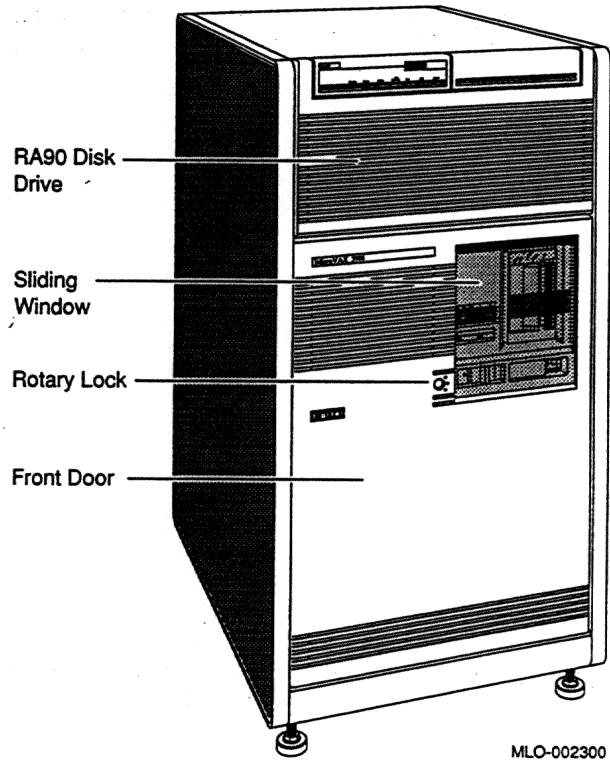

The cabinet door has a sliding window controlled by a three-position rotary lock. You can lock the window in one of three positions: closed, partially open, and fully open. Each position controls access to system controls. When the window is locked in any of the positions, you can raise it to a higher position without locking it. However, you cannot lower it beyond the locked position without using the key.

### 1-4 MicroVAX 3900 VAXserver 3900 Operation

To open the window, turn the key to position 2 or 3, then slide the window down. To close the window, slide the window up, then turn the key to lock the window in position.

Figure 1-4 shows the three key positions and the controls accessible in each position.

**Figure 1-4: Key Positions**

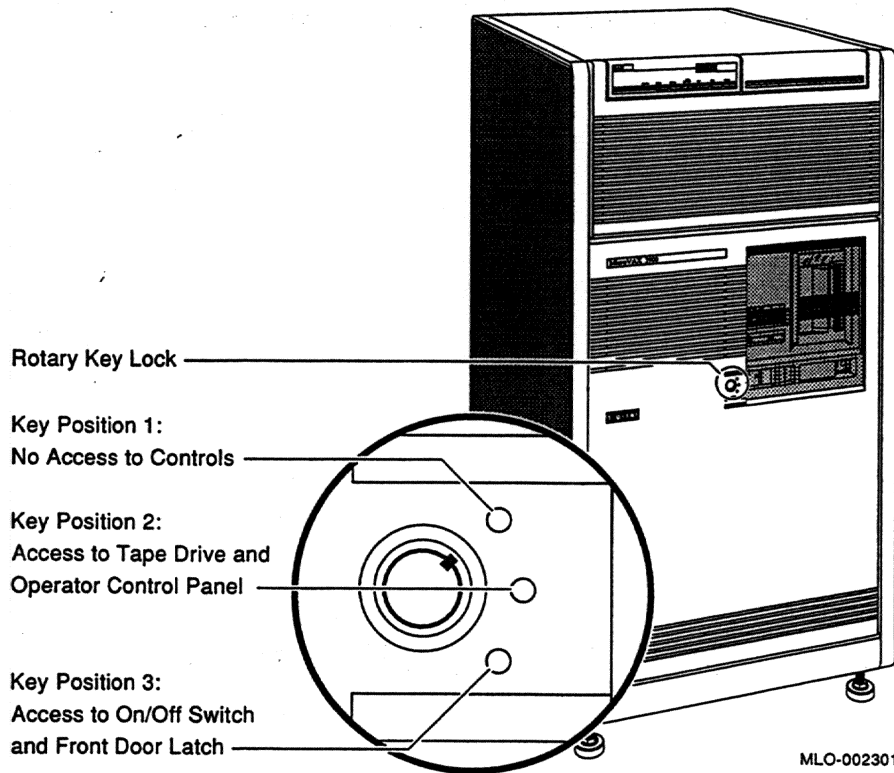

When the window is up and the key is turned to position 1, the window is locked in the closed position. You cannot use any controls when the window is closed, but lights indicating power to the system and activity on the disks and tape are visible through the window. Figure 1-5 shows the closed window and key position.

**Figure 1-5: Sliding Window Closed**

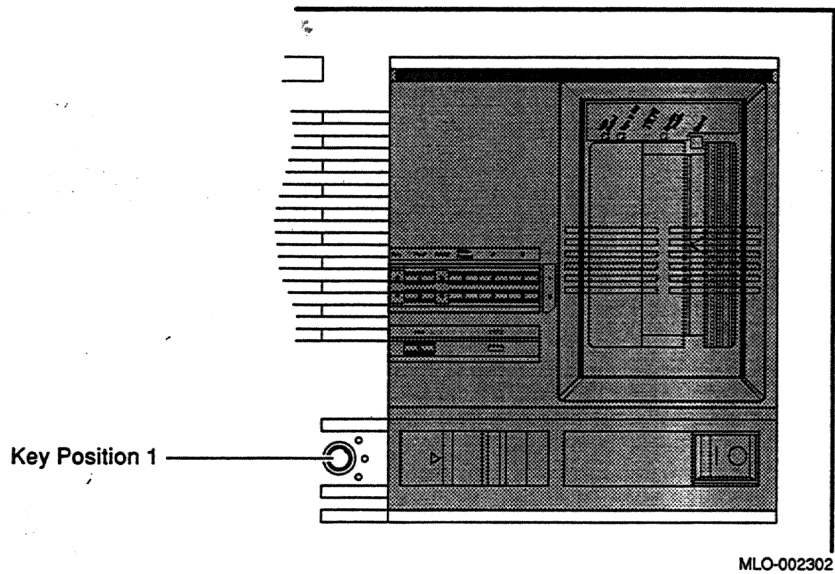

When the key is turned to position 2, you can open the window partially, as shown in Figure 1-6. You can use the TK70 tape drive, operate the controls for the RA70 disk drives, and use the Halt button. Chapter 3 has instructions for using the tape and disk drives.

**Figure 1-6: Window Partially Open**

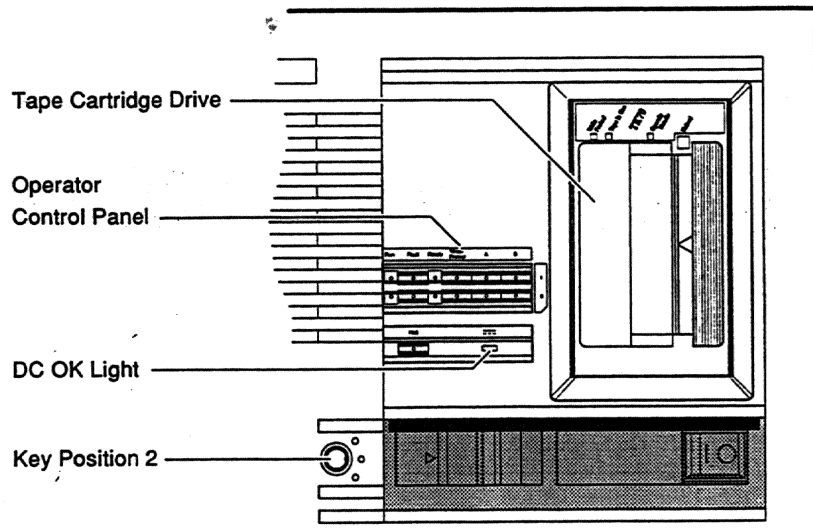

MLO-002303

When the key is turned to position 3, you can open the window fully, as shown in Figure 1-7.

**Figure 1-7: Window Fully Open**

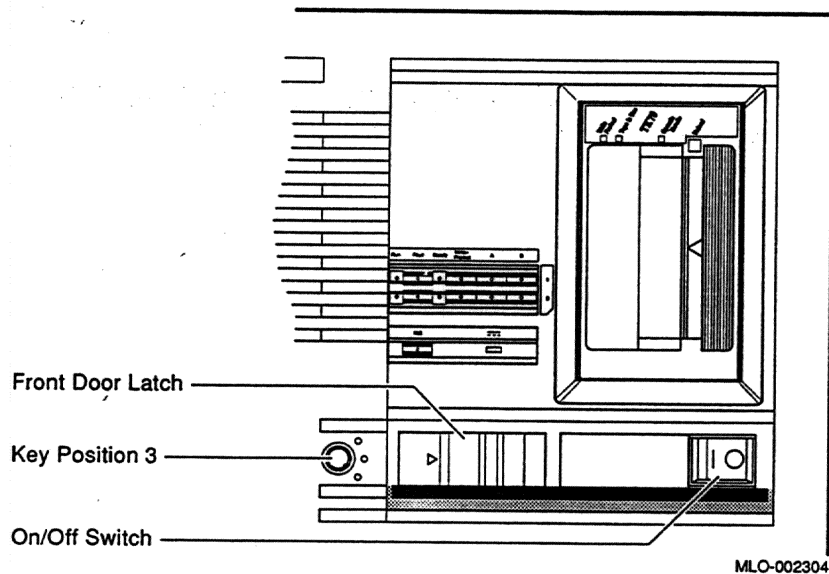

When the window is fully open, you can turn the system on and off, and you can release the latch that locks the front door.

#### **Opening the Front Door**

You must open the front door to use controls on the CPU cover panel and power supplies. Refer to Figure 1-8, and open the front door as follows:

1. Push the door latch to the right. The left side of the door springs open.
2. Pull the door fully open.

**Figure 1-8: Opening the Front Door**

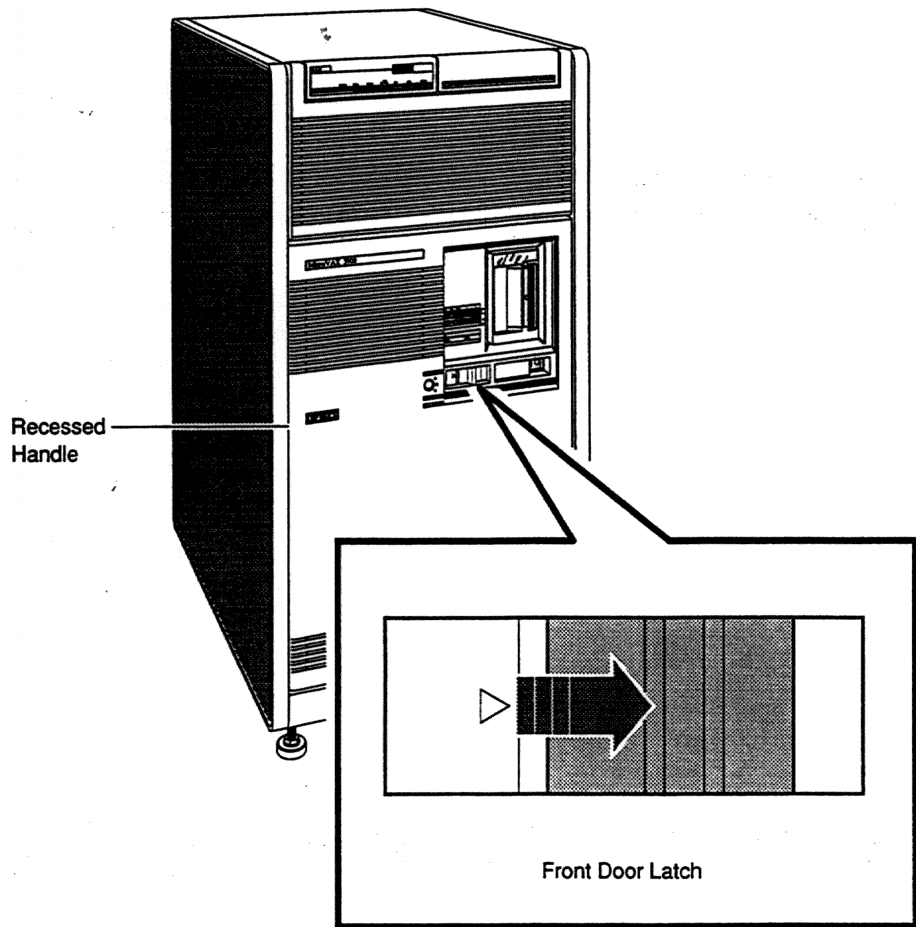

MLO-002305

The next section describes the BA213 chassis, which is exposed when you open the front door.

### 1.1.1 The BA213 Chassis

Opening the front door enables you to see the components housed in the BA213 chassis. Figure 1-9 shows a typical configuration.

**Figure 1-9: Internal View of MicroVAX/VAXserver 3900 Cabinet**

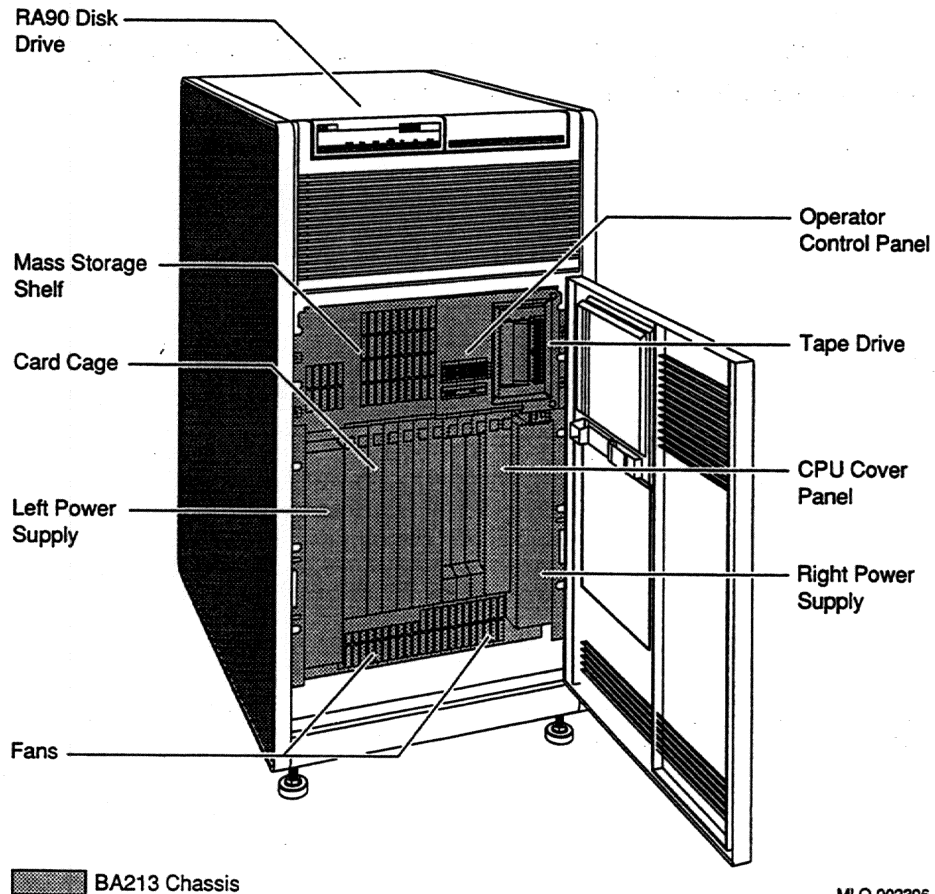

The BA213 chassis contains the following:

- Mass storage—TK70 tape drive and possibly one or two RA70 disk drives



- Card cage containing modules—CPU, memory, communications controllers, mass storage controllers
- Power supplies (2)
- Fans (2)

#### 1.1.1.1 Mass Storage Shelf

The mass storage shelf extends across the top of the enclosure. The shelf contains a TK70 tape drive and, optionally, up to two RA70 fixed-disk drives. The RA70 drives are behind the Operator Control Panel (OCP), as shown in Figure 1-10.

**Figure 1-10: Mass Storage Shelf**

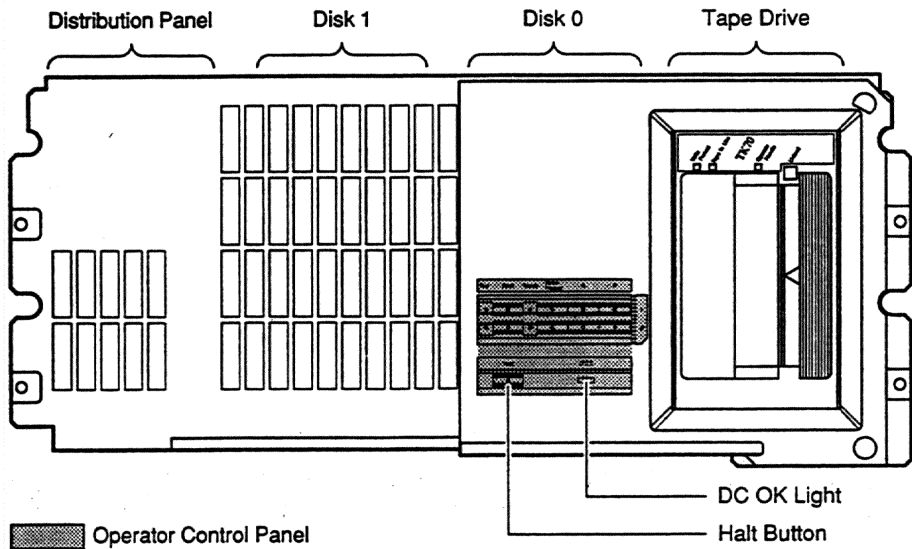

MLO-002307

The OCP has several buttons and indicator lights for each of the two drives. Chapter 3 describes how to use these controls. If your system has no RA70 drives, the drive indicators do not light when you turn on your system.

Below the controls for the RA70 drives is the system DC OK light. When lit, the green DC OK light indicates that the dc voltages are within the correct operating range. When not lit, there is a problem with one of the power supplies. Chapter 3 describes how to check the DC OK light on each power supply to determine which power supply has failed.

To the left of the DC OK light is the Halt button. The Halt button is a two-position button. When you press in the button, the system halts and the console mode prompt >>> appears on the console terminal screen. Before entering console commands, press the button again. If you inadvertently press the Halt button, type `*c`  to continue.

**CAUTION:** *Pressing in the Halt button halts the system regardless of the setting of the Break Enable/Disable switch on the CPU cover panel.*

#### **1.1.1.2 Card Cage**

The modules in your system are mounted in a 12-slot card cage under the mass storage shelf. The slots are numbered from 1 to 12, as shown in Figure 1-11.

**Figure 1-11: Card Cage**

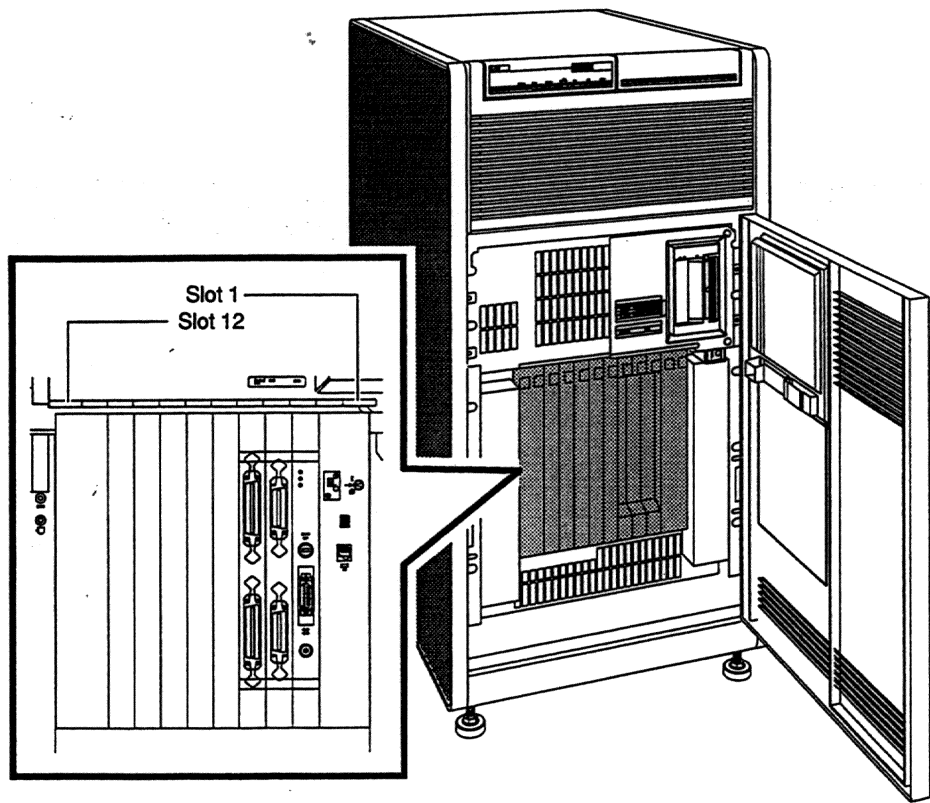

MLO-002308

The number and type of modules installed in your system depend on your configuration. Each slot, even an empty one, is protected by a cover panel. Together the panels form a shield with a three-fold purpose: to protect external devices from electrical interference generated by the system, to protect the system from electrical interference generated by external devices, and to maintain air flow integrity.

**CAUTION:** Do not operate the system without DIGITAL-supplied module cover panels. The cover panels are required to protect the equipment and to meet international regulatory standards. Do not substitute other cover panels as they may not meet the required specifications.

Operating the system without the module cover panels has the following consequences:

- The system may overheat due to improper air circulation.
- The system will not comply with FCC and VDE requirements for shielding and may produce electrical interference that affects other equipment.
- The system is susceptible to electrical interference or damage from external sources.

The design of the cover panels varies, depending on the type of module installed in the slot. Modules requiring external cable connections, such as communications controllers, have recessed cover panels that are riveted directly to the module. The recessed panels allow space for connecting cables. Modules requiring no external cable connections, such as mass storage controllers, are covered by flush cover panels. Empty slots are also covered by flush cover panels which may be single or double width. All cover panels, except those covering empty slots, have a label identifying the module installed in the slot.

Cables connecting your system to peripheral devices (such as terminals, modems, and printers) are attached to communications controllers. Each cable can contain multiple lines. The cables run under the BA213 chassis and out the back of the system cabinet, where the cables are split into individual lines. Chapter 3 describes these connections in more detail.

The MicroVAX central processing unit (CPU) module is installed in slot 1 with its associated memory module in slot 2. Additional memory modules may be installed in slots 3 through 5. The CPU and the first memory module are behind a double-width cover panel that has internal cable connections to the CPU module. Figure 1-12 shows the CPU cover panel.

**Figure 1-12: CPU Cover Panel**

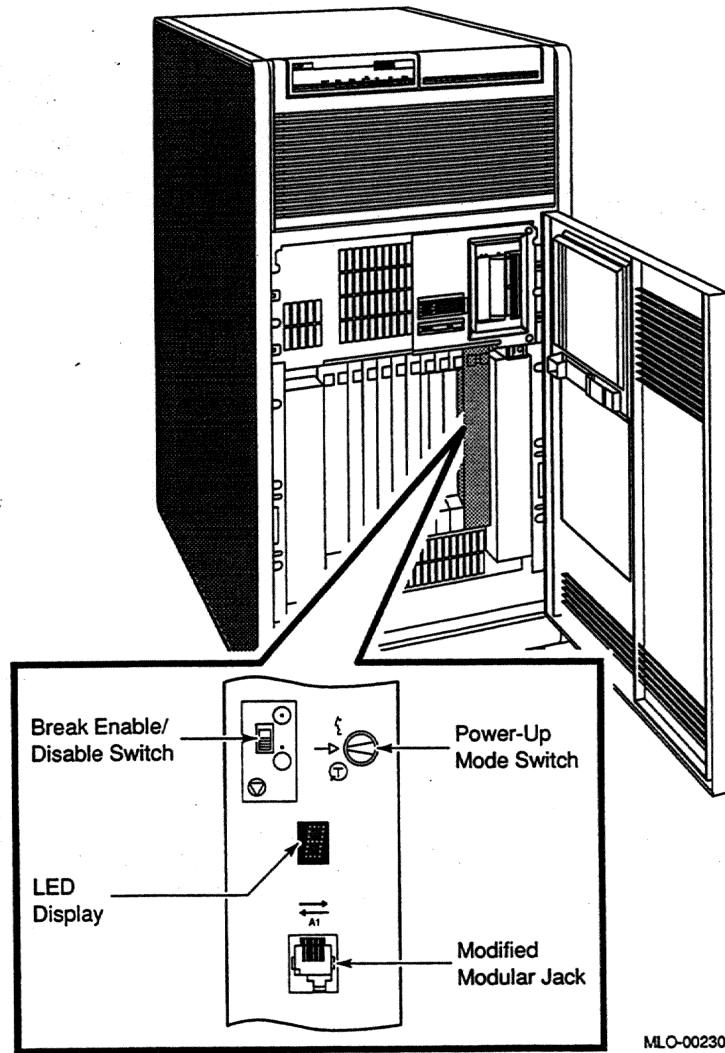

### **CPU Cover Panel Components**

The CPU cover panel has the following components:

- **Break Enable/Disable switch**—When the switch is down (dot outside the circle), breaks are disabled. When the switch is up (dot inside the circle), breaks are enabled.

circle), breaks are enabled. When breaks are enabled, pressing **Break** on the console terminal halts the processor and transfers control to the console program.

- **Power-Up Mode switch**—This three-position rotary switch determines how the system responds at power-up:

Language Inquiry Mode (in the top position, indicated by a human profile) causes the system to display a language selection menu at power-up if your console terminal supports multiple languages.

Run Mode (in the middle position, indicated by an arrow) is the normal operating setting.

Loop Back Test Mode (in the bottom position, indicated by a T in a circle) causes the system to run loopback tests on the console serial line at power-up. This setting requires special loopback connectors and is for service use only.

- The light emitting diode (LED) display shows the testing sequence during power-up.
- **Modified modular jack (MMJ)**—This console terminal connector, labeled A-1, provides the connection for the console terminal.

### 1.1.1.3 Power Supplies

Your system has two power supplies. The right power supply provides power to modules installed in slots 1-6, one or two mass storage devices (the TK70 tape drive and fixed disk 1, if present), and the two fans. The left power supply provides power for modules in slots 7-12 and fixed disk 0, if present. Figure 1-13 shows the controls and indicators on a power supply.

**Figure 1-13: Power Supply**

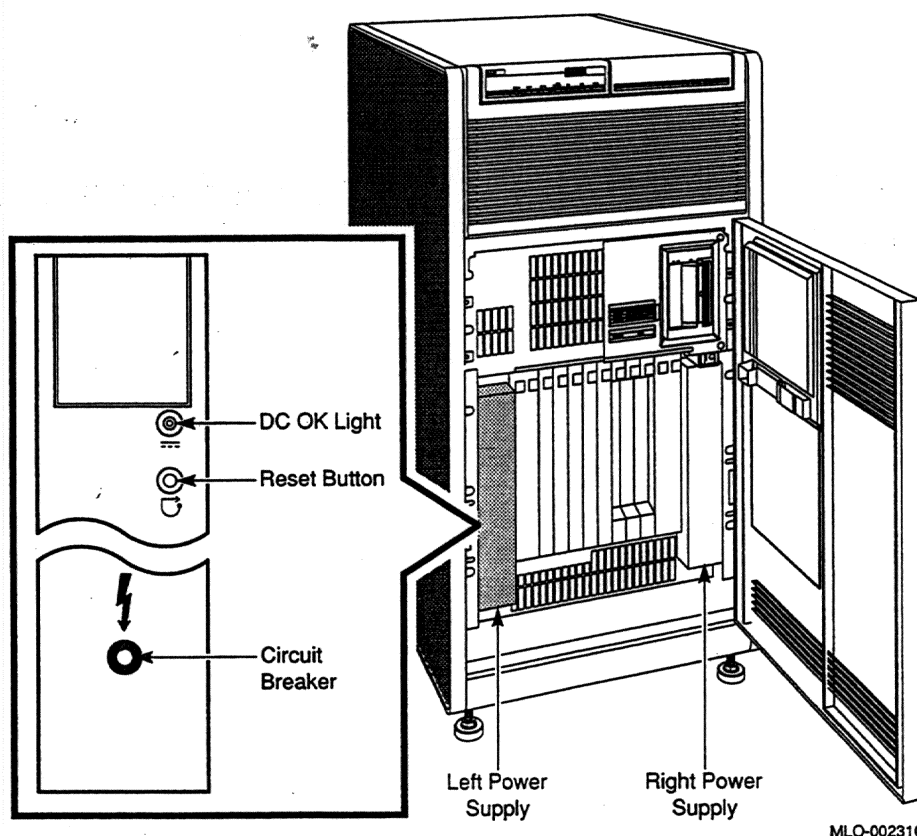

MLO-002310

The controls and indicator lights function as follows:

- **DC OK**—When the DC OK light is lit, the dc voltages are within the correct operating range. An unlit DC OK light indicates a problem with the power supply. Turn off the system and call your DIGITAL service representative.
- **Reset button**—A recessed Reset button enables you to reset the system to a power-on state without turning it off. The Reset button is recessed to prevent you from inadvertently resetting the system. Use your fingertip or small tool to press the button. See Chapter 2 for the correct procedures for resetting the system.

- **Circuit breaker**—The circuit breaker trips to protect the system from power surges. When tripped, the circuit breaker is in the out position. To reset the breaker, press it in.

#### **1.1.1.4 Fans**

Two fans located under the card cage draw air through the BA213 chassis. The fans draw air from the top of the enclosure, down through the card cage, and out the bottom. The speed of the fans varies with the ambient temperature.

Additional fans in the RA90 disk drive unit draw air in through the front and out the back of the drive. Figure 1-14 shows the air flow throughout the entire system cabinet with the front door and window closed.



**Figure 1-14: System Air Circulation**

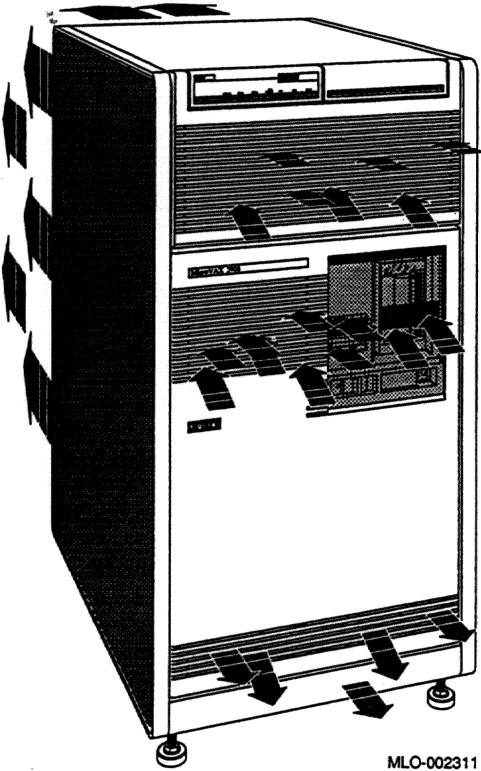

MLO-002311

## 1.1.2 Mass Storage Options

Each MicroVAX 3900/VAXserver 3900 system has one or two RA90 disk drives mounted in the top of the system cabinet. Optionally, one or two RA70 disk drives can be mounted in the BA213 chassis. Additional cabinets can provide for additional mass storage options including:

- RA70 fixed-disk drive
- RA90 fixed-disk drive
- RA82 fixed-disk drive
- RA60 removable disk drive
- TSV05 tape drive
- TU81-Plus tape drive

Instructions for using each of these devices are in Chapter 3.

Consult your DIGITAL sales representative for information on allowable mass storage options.

Each mass storage device listed has its own power supply, but is connected to a power controller in the cabinet in which the device is mounted. The power controller in the system cabinet (described in the next section) distributes ac power to the BA213 chassis and the RA90 disk drives. The power controller in the H9644 expander or additional mass storage cabinets is daisy-chained to the controller in the system cabinet, so the entire system is controlled by the on/off switch on the system cabinet.

## 1.2 Rear View of the MicroVAX/VAXserver 3900

You may need to remove the rear panel of the cabinet to check the RA90 circuit breakers or the system circuit breaker.

You remove the rear panel (Figure 1-15) as follows:

1. Using a one-eighth-inch Allen wrench, turn the two screws counter-clockwise a quarter turn. Support the top of the panel while you loosen the second screw.
2. Tilt the top of the panel out about 3 inches.
3. Lift the panel out of the supporting bracket.

**Figure 1-15: Removing the Rear Panel**

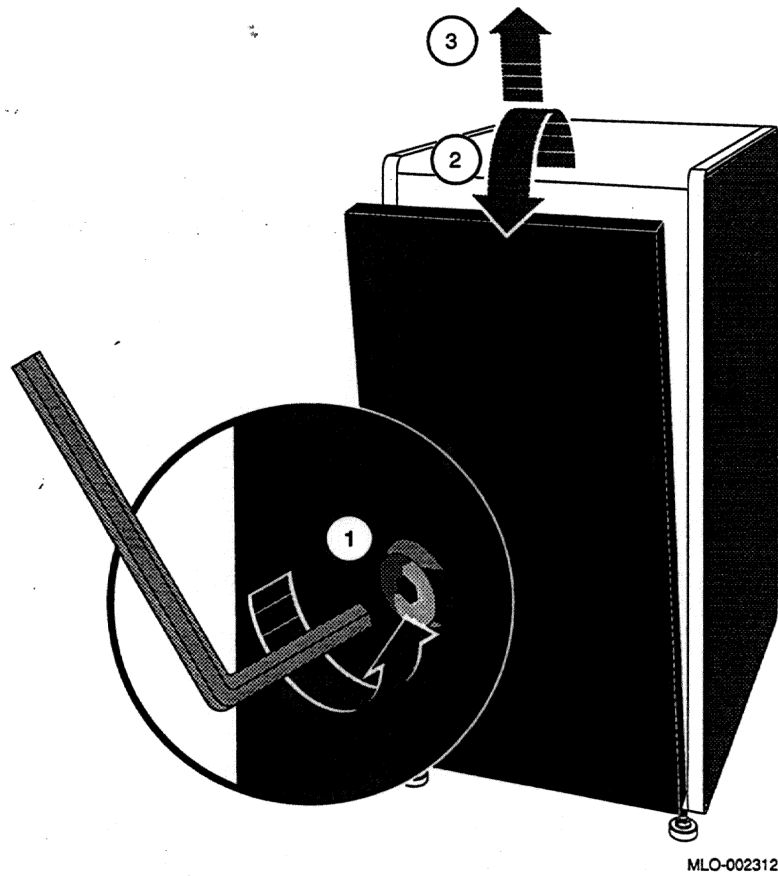

The rear view of a MicroVAX 3900/VAXserver 3900 cabinet containing an RA90 disk drive is shown in Figure 1-16.

**Figure 1-16: Rear View of MicroVAX 3900/VAXserver 3900 Cabinet**

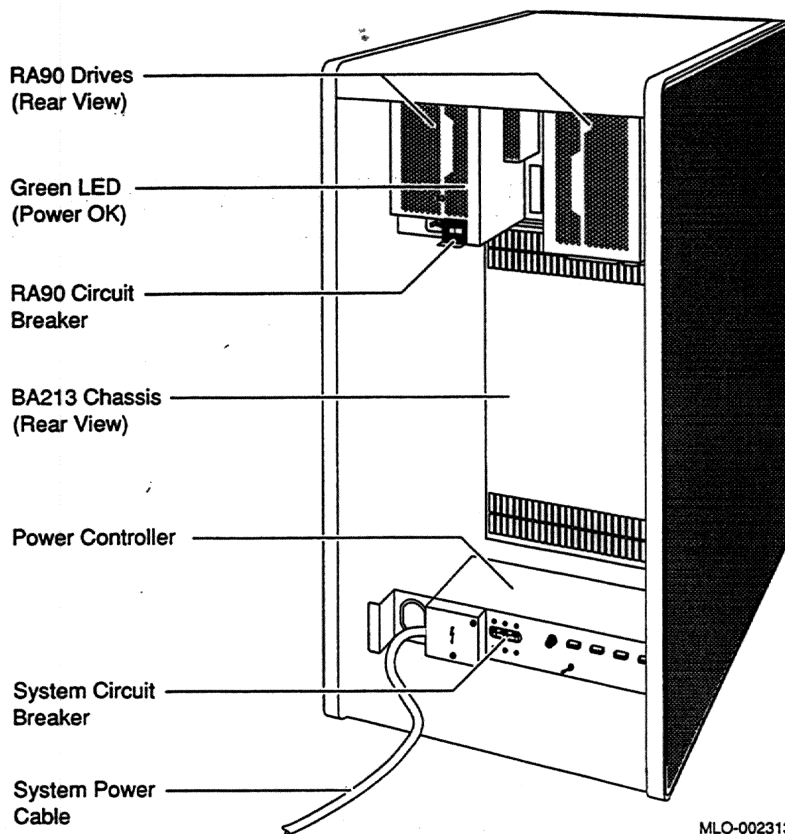

The rear of the RA90 drive has a circuit breaker, a fan to cool the device, and a power cord that is connected to the power controller.

### **1.2.1 Power Controller**

At the bottom of the cabinet is the power controller, which distributes ac power to the BA213 chassis and the RA90 disk drive. Figure 1-17 shows both the front and back view of the power controller. When you look at the rear of the system cabinet, you see the front of the power controller.

**Figure 1-17: Power Controller**

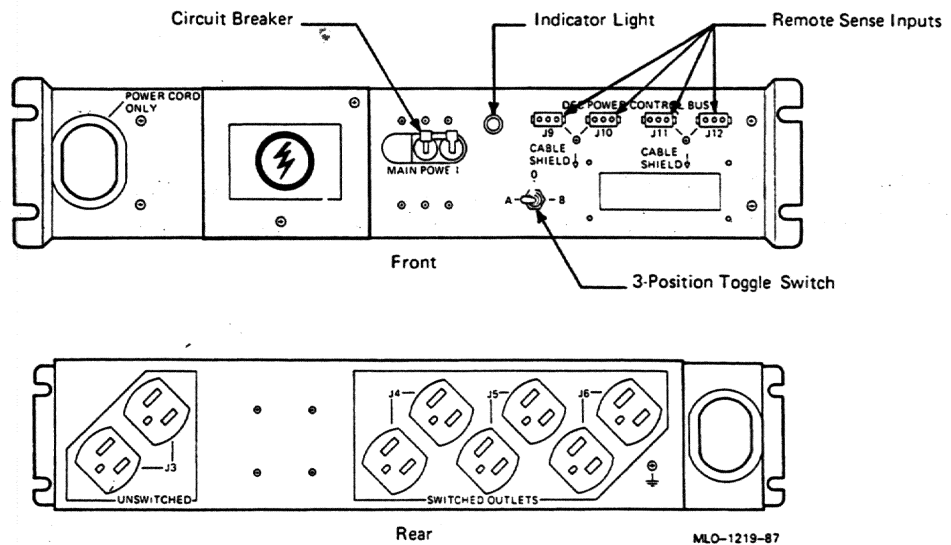

The front of the power controller contains the following components, as shown in Figure 1-17.

- Four remote-sense input connectors (labeled J9, J10, J11, and J12)
- A three-position toggle switch (A, 0, B)
- An indicator light
- A circuit breaker

The rear of the power controller contains the following components, as shown in Figure 1-17.

- Two unswitched power outlets
- Six switched power outlets

The unswitched power outlets are always energized, while the switched power outlets are controlled by the three-position toggle switch and the devices connected to the remote-sense input connectors.

The ac power cord of the BA213 unit is plugged into one of the unswitched power outlets on the power controller. The ac power cord for each mass storage option is plugged into a switched power outlet on the power controller. A remote-sense output connector from the BA213 chassis is

connected to one of the remote-sense input connectors (labeled J9, J10, J11, and J12) on the power controller by a remote power control bus cable.

The three-position toggle switch determines how power is supplied to the switched power outlets on the power controller. When the toggle switch is set to A (the normal operating setting), the switched power outlets are controlled by the on/off switch on the front of the BA213 chassis. When you turn on the system, all mass storage devices plugged into the switched outlets are powered on. When you turn off the system, the mass storage devices are powered off.

Two other settings are possible, but unusual. When the toggle switch is set to 0, the switched power outlets are always de-energized. No power is distributed to mass storage devices connected to the switched outlets when the system is turned on. When the toggle switch is set to B, the switched power outlets are always energized. Power is distributed to mass storage devices connected to the switched outlets whether the system is on or off.

The power controller is protected by a circuit breaker that functions as a system circuit breaker. If the circuit breaker trips, all outlets are de-energized and the entire system loses power. You can reset the breaker by pushing it down, then lifting it up.

The indicator light on the power controller remains lit as long as the system is plugged into an active outlet. The light is unaffected by the operation of the circuit breaker. If the light goes out, the power cord between the power controller and the outlet may be loose, or the outlet may have lost power.

## **1.3 Functional Description of Base System**

Each MicroVAX 3900/VAXserver 3900 system includes base system components common to all systems. Your system may have optional components as well. Your system was configured at the factory, based on your order.

The following sections describe base system components and options.

### **1.3.1 Base System Components**

Base system components include the following:

- Central processing unit (CPU)
- Console serial line unit (SLU)
- Main memory
- Network controller
- Mass storage devices and controllers

#### **1.3.1.1 Central Processing Unit (CPU)**

The central processing unit (CPU) controls the execution of all instructions and processes. The CPU circuits contain the logic, arithmetic, and control functions used by the system.

#### **1.3.1.2 Console Serial Line Unit (SLU)**

Each system has a serial line unit (a line on which each bit of information is sent sequentially on a single channel) connecting the console terminal to the CPU module. The SLU connector (an MMJ) is located on the CPU cover panel. The console serial line provides a means of communicating with the CPU.

#### **1.3.1.3 Main Memory**

Main memory provides the storage area for data and instructions used by the CPU. When you start your system, the operating system is loaded into main memory. Any application programs must also be loaded into memory.

When the system cannot load everything into memory at once, it reads in units of data called pages (512 bytes of data) from disk. Having a larger main memory increases the efficiency of processing, since fewer pages must be copied to and from disk. Each configuration comes with a standard memory option that you can add to increase efficiency.

The contents of memory are volatile. This means they are lost when you turn off power to the system. Use mass storage devices, such as fixed disks and tape cartridges, to store software and data permanently.

#### **1.3.1.4 Network Controller**

Network communications controllers allow you to connect to an Ethernet network. With a network connection and appropriate DECnet software, you can use network services, such as mail; access data stored on other systems; perform operations, such as editing and printing on remote systems; and share resources, such as laser printers. Your system comes with the DESQA Ethernet controller, which allows you to connect to either standard Ethernet cable or to ThinWire Ethernet cable.

#### **1.3.1.5 Mass Storage Devices and Controllers**

Mass storage devices record data on magnetic media. The data recorded is not lost when you turn off the system, but can be altered or erased if you record over the data. Use mass storage devices to store data and software permanently. When the data or software is needed, the CPU transfers it from the mass storage device into main memory. The two primary types

of mass storage devices are fixed disks and devices with removable media, such as tape cartridges.

### **Fixed-Disk Drives**

Fixed-disk drives are permanently installed in your system. They provide large-capacity storage for software and data files, as well as rapid access to the data by the CPU. Your system may have multiple fixed-disk drives.

### **Devices with Removable Media**

Devices with removable media, such as disk packs, tape cartridges, and tapes, are used as both input and output devices. In addition, compact optical disks are used as input devices when you install software or copy data to your system. Tape cartridges are the primary load media for software. You use these devices as output devices when you copy software or data from your system. You can copy individual files or programs, or you can copy (back up) the contents of an entire fixed disk. Tapes and disk packs are commonly used to archive data from systems.

### **Mass Storage Controllers**

All mass storage devices require a controller, a separate module that controls activity between the CPU and the mass storage devices. The controller for the fixed-disk drives (the KDA50) and the controller for the TK70 tape drive (the TQK70) are installed to the left of other modules in the card cage.

## **1.3.2 Optional Components**

System options can include multiples of components that are part of the base system (for example, additional memory modules or disk drives) and the following kinds of options:

- Communications controllers
- Real-time controllers
- Printer interfaces

### **1.3.2.1 Communications Controllers**

Besides the console serial line, most systems have additional communications controllers for connecting additional terminals, and for communicating with other systems over telephone or network lines. Communications controllers provide standard interfaces between peripheral devices and the system. Many communications controllers provide support for multiple data lines.



The following types of communications controllers are available:

- Asynchronous serial controllers
- Synchronous serial controllers
- DEC servers
- Network controllers

Serial controllers transmit data one character at a time. A device at the transmitting end breaks bytes of data into bits. A device at the receiving end assembles incoming bits into bytes of data.

### **Asynchronous Serial Controllers**

Asynchronous serial controllers provide low-speed connections between peripheral devices and the system. Asynchronous communication between the system and the peripheral depends on recognition of a pattern of start and stop bits, not on a time interval.

Asynchronous serial controllers may be divided into those without modem support and those with modem support.

You use serial controllers without modem support to connect additional terminals and printers to your system. For example, the CXA16 module provides connections for up to 16 serial lines with no modem support.

**NOTE:** *Printers equipped with a microprocessor (intelligent printers) may require modem control signals to function correctly. Do not attach a printer requiring modem control signals to a controller with no modem support. Check your printer documentation to determine the proper communications interface for your printer.*

Communications controllers with modem support allow you to communicate over telephone lines. With a modem connected to your system, you can access other computers over phone lines and you can dial into your system from a remote terminal or computer.

Computers transmit digital signals, while telephone lines (with the exception of digital leased lines) transmit analog signals. When two computers communicate over telephone lines, a modem is required at both the transmitting and receiving end of the line. At the transmitting end, the modem converts digital signals from the computer (or terminal) to analog signals prior to transmission. At the receiving end, another modem converts the analog signals back into digital signals the computer can understand.

The degree of modem support depends on the number of modem control signals recognized by the device. Full modem support (according to

DIGITAL standards) requires recognition of eleven signals. The CXY08 module supports up to eight serial lines with full modem support.

### **Synchronous Serial Controllers**

Synchronous serial controllers provide high-speed connections between systems. Communication between synchronous devices depends on time intervals that are synchronized before transmission of data begins. Synchronous devices can also have modem support.

### **DECservers**

DECservers are terminal servers (a combination of hardware and software) that allow you to connect multiple terminals or printers to hosts in an Ethernet Local Area Network (LAN).

Terminal servers perform the functions of traditional data terminal switches but multiplex the lines over the Ethernet. Using a DECserver offloads communications processing from the host system.

### **Network Controllers**

Network communications controllers allow you to connect to an Ethernet network. With a network connection and appropriate DECnet software, you can use network services, such as mail; access data stored on other systems; perform operations, such as editing and printing on remote systems; and share resources, such as laser printers.

#### **1.3.2.2 Real-Time Controllers**

Real-time controllers interface devices that monitor processes, for example, laboratory equipment or manufacturing equipment connected to the system. Typically, real-time controllers are parallel devices, not serial devices.

#### **1.3.2.3 Printer Interfaces**

Some printers require specific interfaces to communicate with the system. For example, the LG01 and LG02 printers require the LPV11-SA interface.

#### **1.3.2.4 Other Available Options**

Your system arrives configured with the options you ordered. As your needs change, you can add more options. Your DIGITAL salesperson can advise you on available options. *MicroVAX 3800/3900 VAXserver 3800/3900 Technical Information* describes the options currently available for MicroVAX 3900/VAXserver 3900 systems. DIGITAL Field Service provides installation for additional options that you can order.

## Chapter 2

# Operating the System

---

This chapter describes how to operate your MicroVAX once the system software has been installed.

### 2.1 Before You Operate the System

This chapter assumes that your system has been properly installed by a DIGITAL service representative. Installation includes running the diagnostic software shipped with your system and installing the base operating system. To install operating system options or layered products, see the instructions in your system software installation manual or layered product installation manual. Some of the instructions may require you to open the front door of the system to change switch settings on the CPU cover panel.

The remainder of this chapter assumes that system software has been installed.

### 2.2 Switch Settings

Switch settings vary, depending on the operation being performed. The next two sections describe switch settings for normal and for special operations. Set the switches according to your needs.

#### 2.2.1 Normal Operation

Switch settings for normal operation are the following:

- The Break Enable/Disable switch on the CPU cover panel is set to disable (down). Once system software is installed, DIGITAL recommends you run your system with halt disabled to prevent the user from inadvertently halting the system by pressing **Break** on the console terminal. Halting the system causes all activity to stop and transfers control to the console program. With halt disabled, your system automatically boots system software when powered up.
- The Power-Up Mode switch on the CPU cover panel is set to Run (indicated by an arrow).

- The baud rate switch on the CPU cover panel is set to 9600.
- The Write-Protect button for each RA70 fixed-disk drive is set to out (not lit). This setting allows system software to write to the disk.
- The Ready button for each RA70 fixed-disk drive is set to out (glows green when the disk is not being used). This setting makes the drive available for use.
- Either the A or B button (or both) for each RA-series drive is on. This setting puts the drive on-line. The difference between A and B is the port used for communications between the drive and the controller.
- The Halt button on the OCP is set to out (not lit).
- For expanded systems, the on/off switch on the H9644 expander should always be set to on (1).

### 2.2.2 Special Operation

Certain operations require that you change some of the normal operating settings.

- If you need the ability to halt the system from the console terminal, for example, when installing system software or performing certain types of backup, set the Halt Enable/Disable switch to enable (up). This allows you to halt the system by pressing **Break** on the console terminal.
- If you want data on a particular fixed disk to be write-protected, you must set the Write-Protect switch to in (glows).

**NOTE:** *Disks containing system software and user accounts must remain write-enabled. Disks containing applications or sensitive data may be write-protected.*

- If you want to use the Language Selection Menu to select a new language for the console program, before you turn on your system, set the Power-Up Mode switch to Language Inquiry Mode. A human profile indicates the language inquiry mode. When you turn on your system, a Language Selection Menu appears, as shown in Figure 2-1.

## Figure 2-1: Language Selection Menu

KA655-A V5.3 VMB 2.7

- 1) Dansk
  - 2) Deutsch (Deutschland/Osterreich)
  - 3) Deutsch (Schweiz)
  - 4) English (United Kingdom)
  - 5) English (United States/Canada)
  - 6) Español
  - 7) Français (Canada)
  - 8) Français (France/Belgique)
  - 9) Français (Suisse)
  - 10) Italiano
  - 11) Nederlands
  - 12) Norsk
  - 13) Português
  - 14) Suomi
  - 15) Svenska
- (1..15):

Select a language by typing in the number listed next to the language. Save the language you have selected by rotating the Power-Up Mode switch to Run Mode, indicated by an arrow.

If the Power-Up Mode switch is set to Run Mode (indicated by an arrow), then the language selected is saved and is automatically used during subsequent reboots of the system.

**NOTE:** *If the Power-Up Mode switch is set to Language Inquiry Mode (indicated by the human profile), the system will prompt for the language at each power-up.*

In addition to the Language Selection Menu, the system may issue a list of bootable devices and prompt you to select a device from the list. If this happens, refer to Section 2.4.1 for more information.

If your system has been powered off for more than 10 days, the battery unit that saves the system clock and the language selection may have run down. The Language Selection Menu will automatically display when you power up your system, regardless of the Power-Up Mode switch setting. Once the system is booted, reset the system clock, as described in your system software manual.

## 2.3 Turning On the System

Once you have set the switches correctly, you are ready to turn on the system. Use the following procedure:

1. Turn on the console terminal and wait for it to complete its self-tests.
2. Turn on the system by setting the on/off switch on the system cabinet to 1. The switch glows to indicate power to the system.

**NOTE:** *If you have an expanded system, the on/off switch on the H9644 expander should always remain in the on position (1). A signal from the MicroVAX or VAXserver 3900 causes the expander to power up when you turn on the system cabinet.*

When you turn on the power, you should see the indications listed in Table 2-1.

**Table 2-1: Normal Power-On Indications**

Indicator	Normal Indication
On/Off switch	Glow amber
System DC OK light	Glow green
RA70 Ready lights	Glow green steadily within 60 seconds
RA90 Four-character alphanumeric display	Blank for one second; "WAIT" displays for 16 seconds as drive-resident diagnostics are run; the drive unit number displays. <sup>1</sup>
RA90/82/60 Ready lights	Glow white steadily within 60 seconds
RA90/82/60 Run lights	Glow yellow
TK70 tape drive indicator lights	Orange, yellow, and green lights glow during self-tests. The green light remains on.

<sup>1</sup>If no unit number has been previously programmed, "0000" displays.

If you do not observe the indications in Table 2-1, refer to *MicroVAX Troubleshooting and Diagnostics*.

Every time you turn on your system, it runs a series of self-tests on the CPU and memory. Your console terminal first displays a line of information identifying the CPU, the version of the firmware, and the version of VMB—

the primary bootstrap program. In the sample screen shown in Figure 2-2, the CPU is identified as a KA655-A, the version of the firmware is V5.3, and the version of VMB is 2.7. These version numbers may differ from those on your system. The console terminal then displays a countdown as the system tests itself. When the self-tests are successful, the system either autoboots system software or goes into console mode, as described in Sections 2.4.1 and 2.4.2.

When your system detects an error during its self-tests, it displays an error summary consisting of several lines of hexadecimal numbers. A DIGITAL service representative can use the error summary to diagnose the system. Depending on the type of error, one or more error summaries may display on the console terminal. A sample error summary is shown in Figure 2-2.

**Figure 2-2: Sample Error Summary**

```
KA655-A V5.3 VMB 2.7
Performing normal system tests.
40..39..38..37..36..35..34..
?30 2 04 FF 00 0000
P1=00000001 P2=9F600001 P3=00000000 P4=000F0000 P5=06060606
P6=00020000 P7=00000064 P8=A002000A P9=20051A6F P10=20051D98
r0=9F600001 r1=00002000 r2=00000002 r3=00000000 r4=FFFFFFFE
r5=200519B2 r6=00000001 r7=20080144 r8=00000000 ERF=80000180
Normal operation not possible.
>>>
```

If possible, print out the error summary and give it to your DIGITAL service representative.

## 2.4 Booting the System

MicroVAX/VAXserver 3900 systems boot in one of two ways. You can manually boot the system from console mode or you can configure the system to autoboot on power-up. The Break Enable/Disable switch setting determines how the system boots.

### 2.4.1 Autobooting the System

When the Break Enable/Disable switch is set to disable (down, the normal operating setting), the system runs self-tests and, on completion, attempts to load system software.

Depending on whether or not a boot device has been selected, the system loads system software or prompts you to select a boot device.

### Loading System Software (When a Boot Device Has Been Selected)

When a boot device has been selected, the system identifies the boot device and the number "2" displays on the screen. As the system begins booting, the countdown continues from 1 to 0.

Figure 2-3 shows a successful power-on and automatic boot when device DUA0 has been selected as the boot device.

#### Figure 2-3: Successful Power-On and Automatic Boot

```
KA655-A V5.3, VMB 2.7
```

```
Performing normal system tests.
```

```
40..39..38..37..36..35..34..33..32..31..30..29..28..27..26..25..  
24..23..22..21..20..19..18..17..16..15..14..13..12..11..10..09..  
08..07..06..05..04..03..
```

```
Tests completed.
```

```
Loading system software.
```

```
(BOOT/R5:0 DUA0)
```

```
  2..  
--DUA0
```

```
  1..0..
```

### Loading System Software (If You Have Not Selected a Boot Device)

If you have not selected a boot device when the Break Enable/Disable switch is set to disable, the system runs self-tests, and on completion, issues a list of bootable devices. You are prompted to select a boot device from the list, as shown in Figure 2-4.



## Figure 2-4: Successful Power-On to List of Bootable Devices

KA655-A V5.3 VMB 2.7

Performing normal system tests.

40..39..38..37..36..35..34..33..32..31..30..29..28..27..26..25..  
24..23..22..21..20..19..18..17..16..15..14..13..12..11..10..09..  
08..07..06..05..04..03..

Tests completed.

Loading system software.

No default boot device is set.

Devices:

--DUA0 (RA70 or RA90)

--MUA0 (TK70)

--XQA0 (08-00-2B-03-50-5C)

--DEVICE? [XQA0]:

To select a boot device, type in a device name at the system prompt. When you have selected a boot device, the system boots from that device. Figure 2-3 shows a successful power-on when DUA0 has been selected as the boot device. The next time the system is turned on, it will autoboot from the device you have just selected.

**NOTE:** *If you do not type a device name within thirty seconds, the system attempts to boot from the Ethernet device, XQA0.*

### Changing the Boot Device

Once a boot device is identified, the system autoboots from that device each time you turn it on, until you do one of the following:

- Change the setting of the Break Enable/Disable switch to enable (up—dot inside the circle). (If you do so, the system will not autoboot but will enter console mode after completing self-tests.)
- Change the boot device by using the “SET BOOT *device name*” command.

### Using the SET BOOT Command

To direct the system to boot automatically from a specific device or to change the setting of the default boot device, put the system into console mode and at the >>> prompt, enter “SET BOOT *device-name*”. For example, “SET BOOT XQA0” sets the system default boot device to be the Ethernet controller.

Once you have selected a boot device, the system autoboots from that device each time you turn it on. To determine the name of the device to boot the system from, refer to Table 2-2.

**NOTE:** *Selecting a default boot device other than the Ethernet device, XQA0, is not appropriate for diskless and tapeless systems which must boot software over the network.*

**Table 2-2: Device Names**

Controller Type	Controller	Device Name
MSCP (Disk)	KDA50	DJmn <sup>1</sup> (removable disks)
MSCP (Disk)	KDA50	DUmn <sup>2</sup> (fixed disks)
MSCP (Tape)	TQK70	MUmn
PROM	MRV11	PRAn
Ethernet adapter	DESQA	XQAn

<sup>1</sup>m = MSCP controller designator (A = first, B = second, etc.)  
n = unit number

<sup>2</sup>When under operating system control, these devices are identified as DImn.

For more information on console commands and the booting process, refer to *MicroVAX 3800/3900 VAXserver 3800/3900 Technical Information*.

## 2.4.2 Booting the System from Console Mode

When the Break Enable/Disable switch is set to enable, the system powers up to console mode (indicated by the >>> prompt) after successfully completing its self-tests. Figure 2-5 shows a successful power-on to console mode.

**Figure 2-5: Successful Power-On to Console Mode**

KA655-A V5.3, VMB 2.7

Performing normal system tests.

40..39...38..37..36..35..34..33..32..31..30..29..28..27..26..25..  
24..23..22..21..20..19..18..17..16..15..14..13..12..11..10..09..  
08..07..06..05..04..03..

Tests completed.

>>>

### **Loading System Software**

To load system software from console mode, enter the BOOT command, "BOOT *device name*". For example,

>>> **BOOT MUA0**

tells the system to boot software from a cartridge in the TK70 tape drive.

**NOTE:** To determine the name of the device from which to boot the system, refer to Table 2-2.

Software manuals may instruct you to power up with break enabled and to use the BOOT command.

## **2.5 Using the System**

Once the system software is loaded, the first display for the system software appears on the console terminal after a few seconds. That display is described in the system software documentation.

You are now ready to use the system. Refer to the system software manuals and application manuals for more specific instructions on using the system.

Your system software manuals cover the following:

- Installing software on your system
- Running software to perform tasks
- Making and restoring backup copies of system software or data files
- Accessing devices and utilities in your system

## 2.6 Turning Off the System

Do not turn off your system unless it requires maintenance or you know of a planned power outage.

**CAUTION:** *Turning off your system without following the shutdown procedure described in your system software manuals may result in loss of data.*

Once you have completed the recommended procedure, you should spin down your RA90 drives and then turn off your system by setting the on/off switch to 0.

**CAUTION:** *If you are using a system that is part of a VAXcluster, do not turn off, halt, or restart the system without consulting the cluster manager. Performing any of these activities will interrupt the processes of the entire cluster.*

## 2.7 Halting the System

Halting the system interrupts all processes and returns control to the console program. You may need to halt the system during software installation. Or, you may want to boot the system from another device, for example, a tape cartridge containing MicroVAX Diagnostic Monitor (MDM) software.

**CAUTION:** *Halting your system without following the shutdown procedure described in your system software manuals may result in loss of data.*

You can halt the system in two ways:

- You can press the Halt button twice—in to halt the system, and out to enter console mode.
- If the Break Enable/Disable switch on the CPU cover panel is set to enable (up—indicated by the dot inside the circle), you can press the **Break** key on the console terminal. If the Halt Enable/Disable switch is not set to enable and you wish to halt the system by pressing **Break**, change the setting of the Halt Enable/Disable switch from disable to enable.

When the console mode prompt >>> displays on your screen, the system is halted.

If you inadvertently halt the system, type "c **Return**" at the console prompt. The processes interrupted by the halt continue.

## 2.8 Restarting the System

**NOTE:** *Restarting the system aborts all current and pending operations. To prevent loss of data, warn all users to log off prior to restarting the system.*

Restarting returns the system to a power-on condition. All current and pending operations are aborted and the usual power-on tests are run.

You restart the system by opening the front door of the system and pressing the Reset button on either power supply.

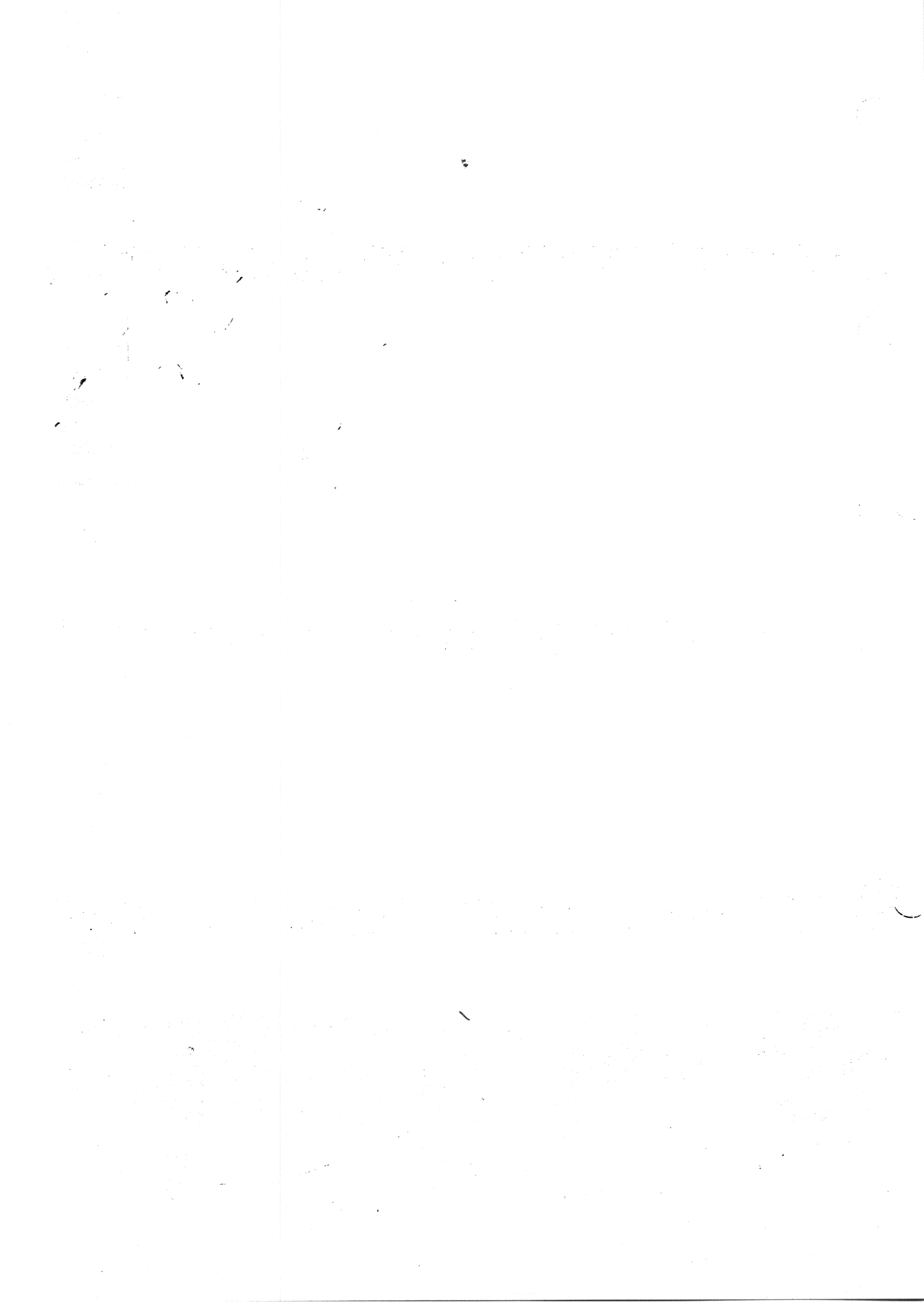

## Chapter 3

# Operating System Options

---

This chapter describes how to use options that may already be part of your system, or that you can add to your system. The following types of options are covered:

- Mass storage devices and controllers
- Communications controllers
- Real-time controllers
- Printers

### 3.1 Mass Storage Options

This section describes how to operate the controls for mass storage devices. In the case of removable media, it also describes how to insert and remove the media. Operation instructions are provided for RA-series disk drives, the TK70 tape drive, as well the TSV05 and TU81-Plus tape drives.

**NOTE:** *RA60/82 disk drives and the TSV05 and TU81-Plus tape drives cannot be included in the system cabinet; these storage subsystems have their own cabinets.*

To use any mass storage device, you must properly identify the device to the operating system and use appropriate operating system commands. Refer to your system software documentation for details.

#### 3.1.1 RA-Series Disk Drives

RA-series disk drives provide high-volume mass storage for your MicroVAX/VAXserver system. Your system may have up to four RA devices mounted within the system cabinet (two RA70 drives in the BA213 chassis and two RA90 drives mounted at the top of the system cabinet). Expanded systems with a second KDA50 controller (located in the H9644 expander) may have up to eight RA-series devices.

Before you can use RA-series drives, you must identify them to the system by giving each drive a unique address. To determine how to number each drive, use the documentation that accompanies each drive.

When your system has multiple disks (drives), DIGITAL recommends that you separate them according to function. For example, if your system has three disks, you may want to use them as follows:

- Disk 0 contains the operating system and applications installed on the system.
- Disk 1 contains a data base or files accessible to all users, subject to the normal file protection explained in your software manuals.
- Disk 2 contains work areas for each user with an account on the system.

The storage capacities and other specifications of the various disk drives in the RA series are listed in *MicroVAX 3800/3900 VAXserver 3800/3900 Technical Information*.

This section covers the following:

- RA90 disk drive controls
- RA60/70/82 disk drive controls
- Inserting RA60 disk packs
- Removing RA60 disk packs
- Cleaning the RA82 filter

#### **3.1.1.1 RA90 Controls and Indicators**

Controls and indicators for each RA90 drive are on a control panel located on the front of the drive. Figure 3-1 shows the control panel for an RA90 disk drive.

There are no physical in/out states for the switches on the RA90 control panel. Instead, the logical state of the switch changes each time a switch is selected, similar to the way a calculator keypad works. Table 3-1 lists the function of each switch and indicator for RA90 drives.



Figure 3-1: RA90 Fixed Disk Drive Controls

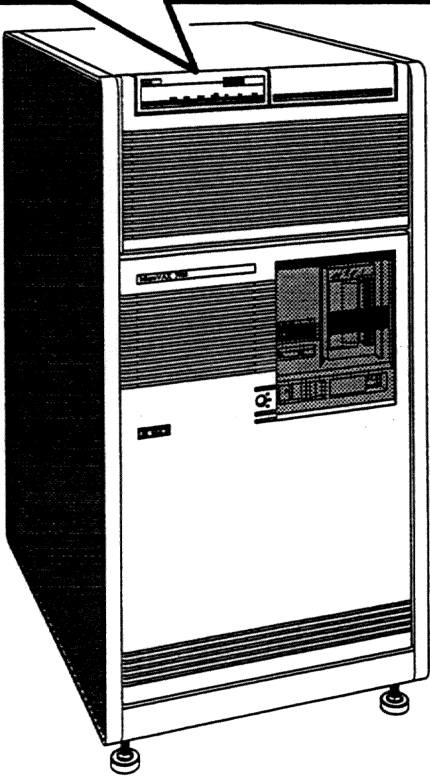
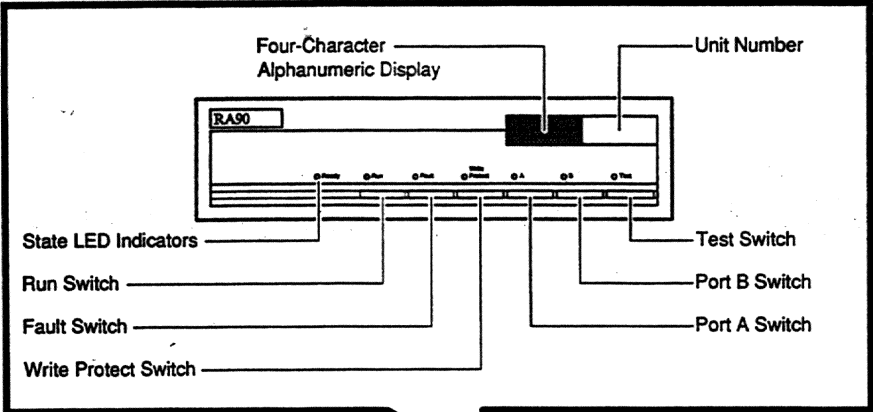

MLO-002315

**Table 3-1: RA90 Disk Drive Controls and Indicators**

Control	Indicator	Function
Run		Selecting the Run switch causes an "R" to display in the control panel display and the drive to spin up. Additionally, the Run indicator lights.
Ready	Lit	The Ready indicator lights once the drive is up to speed.
A (port)		Selecting the Port A switch displays an "A" in the control panel display and logically makes the drive available to the controller. The A (port) indicator lights only when the controller communicates with the drive.
B (port)		Selecting the Port B switch displays a "B" in the control panel display and logically makes the drive available to the controller. The B (port) indicator lights only when the controller communicates with the drive.
Write-Protect		Selecting the Write-Protect switch logically write-protects the drive and causes a "W" to display in the control panel display. Additionally, Write-Protect indicator lights.
Fault	Lit	Selecting the Fault switch when the Fault indicator is lit displays an error code. Record the error code and refer to <i>MicroVAX Troubleshooting and Diagnostics</i> . Selecting the Fault switch a second time clears the error code display.
	Not Lit	Selecting the Fault switch when the Fault indicator is not lit causes a 2-second lamp test of the control panel.
Test		Selecting the Test switch with Port A or B selected causes a 2-second display of the unit address.
		Selecting the Test switch without Port A or B selected causes the drive to enter the test mode. Refer to the <i>RA90 Disk Drive User Guide</i> for information on running tests.

When both the Run and Ready indicators are lit, the disk is available for use. The Write-Protect switch controls whether the system can write data to the disk drive. The system can read from the disk regardless of whether or not the Write-Protect switch is selected. When selected, a "W" displays on the RA90 control panel, and the Write-Protect indicator lights. Write

protection is used to prevent a disk containing sensitive data from being changed or accidentally erased.

During normal operation, the system disk (the disk containing system software) and disks containing work areas for users should be write-enabled, which allows the system to write to the disk.

When powering down the system, first spin down the RA90 disk drive by deselecting the Run switch.

#### **Programming the Drive Unit Address**

RA90 drives are assigned a drive unit address when installed by your DIGITAL service representative. The unit address is stored in Electrically Erasable Programmable Read-Only Memory (EEPROM) in the RA90 drive and is not lost if the drive loses power. Selecting the Test switch with Ports A or B selected results in a 2-second display of the unit address.

The unit address can be changed by following the procedure described in the flowchart in Figure 3-2. Unit addresses from 0 to 4094 are programmable.

**Figure 3-2: RA90 Unit Address Selection Flowchart**

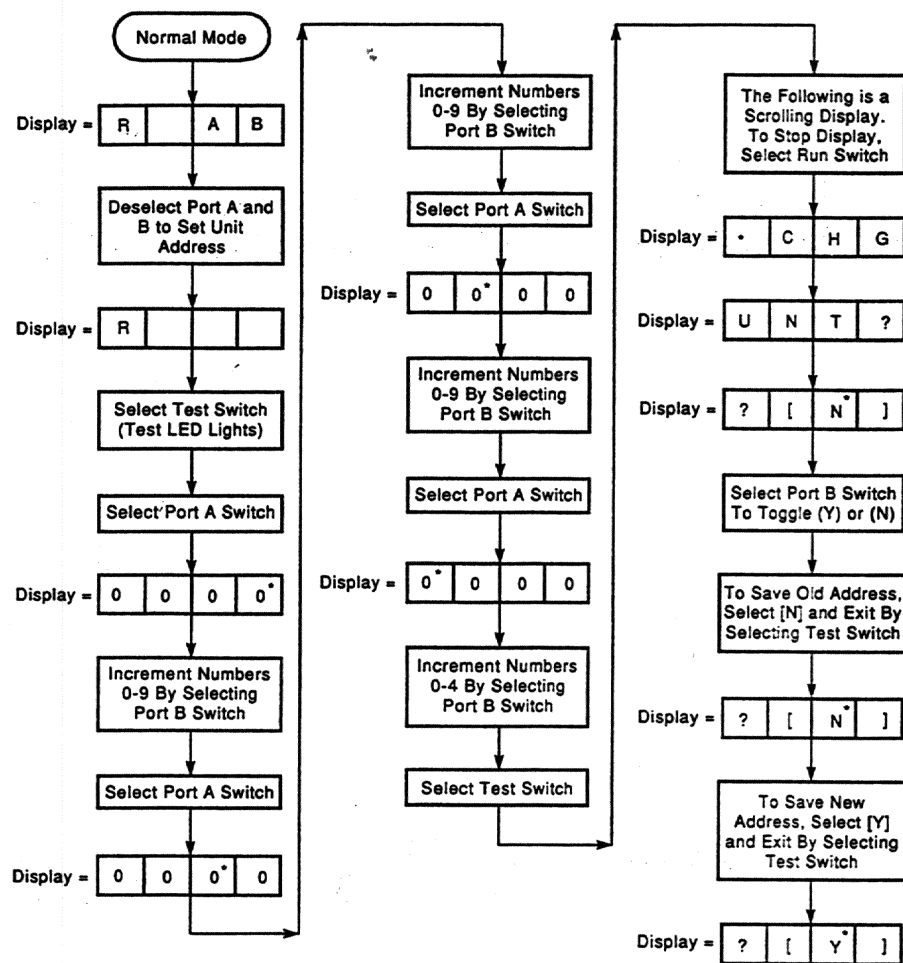

\* Indicates flashing readout

MLO-002316

### 3.1.1.2 RA60/70/82 Drive Controls and Indicators

Your system may have RA60/RA82 drives located in an optional auxiliary cabinet. Controls for the RA60/RA82 drives are located on the front control panel of each device.

Controls for RA70 drives are located on the Operator Control Panel behind the sliding plastic window on the front door of the system. To access the

controls for the RA70 disk drives, you must turn the key to position 2 or 3 and slide down the plastic window. Figure 3-3 shows the location of these controls.

**Figure 3-3: Location of RA70 Drive Controls**

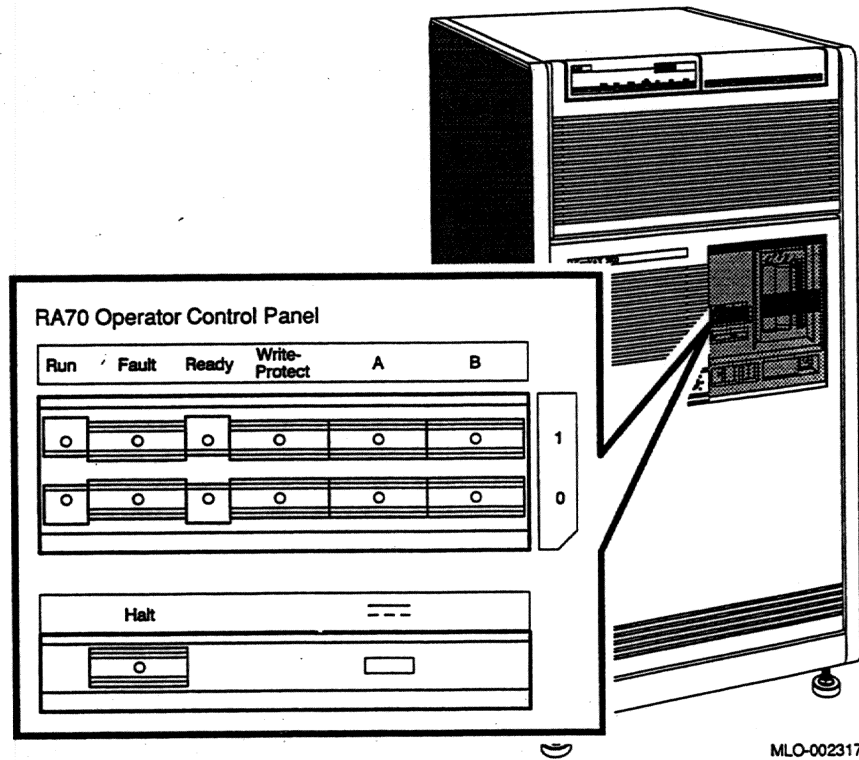

The controls and indicators for all RA-series drives are similar. The control panels on the RA60 and RA82 are identical.

Table 3-2 lists the function of RA60/70/82 disk drive controls.

**Table 3-2: RA-Series Drive Controls and Indicators**

<b>Control</b>	<b>Position</b>	<b>Function</b>
Run/Stop (RA60/82)	In (lit)	Spins up the disk drive for use. The Run/Stop indicator always lights when the button is in. When the Ready light comes on, the disk drive is ready to use.
	Out (not lit)	Spins down the disk drive. When the Run/Stop button is out, the drive has stopped spinning.
Run (RA70)	Lit	Indicates that the drive is spinning. When the Ready light comes on, the drive is ready to use.
	Not lit	Indicates that the drive has stopped spinning. Since the drive cannot be spun down in MicroVAX/VAXserver systems, an unlit Run light indicates a problem. Refer to <i>MicroVAX Troubleshooting and Diagnostics</i> for instructions.
Fault	Lit	Indicates an error condition within the disk drive.
	Not lit	Indicates an error-free condition within the disk drive.
Ready	Lit	Indicates the disk drive is ready to read or write information on the disk.
	Not lit	Indicates the drive is not ready to use. The drive could still be spinning up or could be dismounted as a result of a software command.
Write-Protect	In (lit)	Disk is write-protected. Prevents system software from writing on the disk.
	Out (not lit)	Disk is not write-protected. Normal position for software operation. System software is free to read or write information on the disk.
A	In (lit or not lit)	Normal operating position. Indicates the disk drive can communicate with the system through port A. While communication is occurring, the light is lit.
	Out (not lit)	Indicates the disk drive cannot communicate with the system through port A.

**Table 3-2 (Cont.): RA-Series Drive Controls and Indicators**

Control	Position	Function
B	In (lit or not lit)	Indicates the disk drive can communicate with the system through port B. While communication is occurring, the light is lit.
	Out (not lit)	Indicates the disk drive cannot communicate with the system through port B.

For more specific information about each drive, refer to the documentation that accompanies that drive.

Note that the RA70 always spins up when the system is turned on. You cannot spin down the drive as you can with the Run/Stop button on the RA60/82 or the Run button on the RA90. Both the Run/Stop and Run indicator lights are lit when the spindle is in motion. When both the Run and Ready lights are lit, the disk drive is available for use.

When the Ready light is on, the disk is ready to perform read/write operations. When the light blinks, the drive is performing continuous seek operations. (A seek involves moving the heads of the drive to the appropriate cylinder to read data.) When the Ready light is off, the disk is either spun down (the Run/Stop light<sup>1</sup> is also off) or disabled by a software command (the Run/Stop light is on).

The Write-Protect button controls whether the system can write data to the disk drive. The system can read from the disk regardless of the setting of the Write-Protect button. When the Write-Protect button is out (not lit), the system can write to the disk. Your system disk (the disk containing system software) and disks containing work areas for users should be write-enabled, the normal operating setting.

If you want to write-protect a disk containing sensitive data that you do not want changed or accidentally erased, set the Write-Protect button to in (lit).

### 3.1.1.3 RA60 Disk Pack

The RA60 removable disk drive is located at the top of an auxiliary cabinet. You insert and remove disk packs from the top of the system.

Insert a disk pack as follows:

1. Set the power switch on the system control panel to 1. You cannot open the RA60 disk drive unless the system is turned on.

<sup>1</sup> On an RA90 disk drive, this is the Run light.

2. Make sure the Run/Stop button is in the out (not lit) position.
3. Press the cover release button on the RA60 disk drive control panel and raise the disk drive cover, as shown in Figure 3-4.

**Figure 3-4: Opening the RA60 Disk Drive**

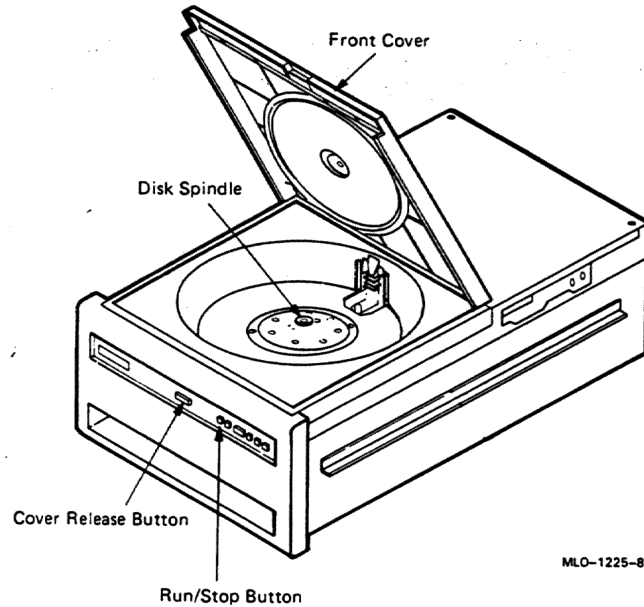

MLO-1225-87

4. Remove the bottom dust cover from the disk pack canister by squeezing together the two slide buttons on its underside, as shown in Figure 3-5. Avoid contact with the exposed disks inside the canister.



**Figure 3-5: Removing Bottom Dust Cover from an RA60 Disk Pack**

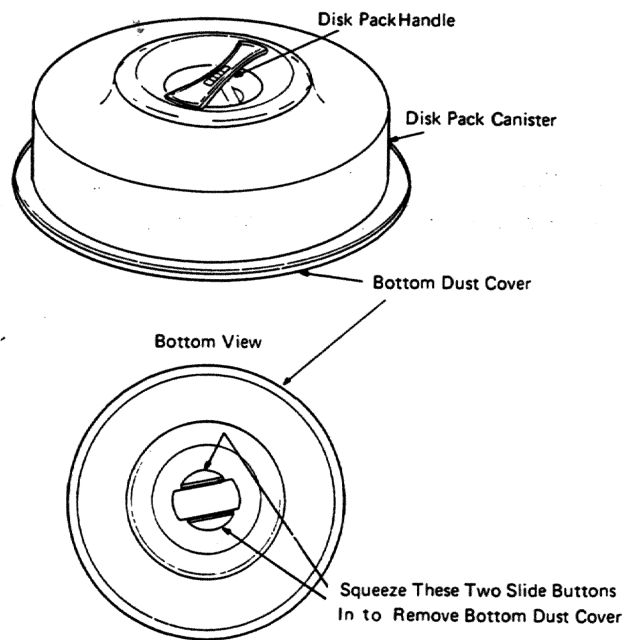

MLO-1226-87

5. Lifting the canister solely by its handle, set the pack onto the disk spindle.
6. Using one hand to turn the handle and the other to hold the disk pack stationary, press down on the handle and rotate it to the right until it stops.
7. Remove the disk pack canister from the disk pack.
8. Place the empty disk pack canister on the bottom dust cover.
9. Close the RA60 drive cover.

Remove an RA60 disk pack as follows:

1. Press the Run/Stop button to the out position and wait for the light to go off.
2. Press the cover release button on the RA60 control panel and raise the RA60 drive cover.

3. Center the storage canister over the disk pack so that the post protruding from the center of the disk pack contacts the canister handle.
4. Using one hand to turn the handle and the other to hold the disk pack stationary, press down on the handle and rotate it to the left until the disk pack is free of the spindle.
5. Using two hands if necessary, lift the disk pack by its handle until it is free from the spindle. Avoid contact with the exposed disk on the bottom of the pack.
6. Install the bottom dust cover on the base of the disk pack storage canister by gently pressing on the cover until it locks in place.

#### **3.1.1.4 Replacing an RA82 Air Filter**

The air filters on RA82 drives should be cleaned or replaced every six months. Replace an air filter as follows:

1. Pull down the access door on the front bezel of the drive. See Figure 3-6.

**NOTE:** *Do not place tools or lean on the open access door. Damage to the hinge mechanism can result.*

2. Grasp the filter and pull outward until it is free of the bezel.
3. Slide the new filter into place inside the bezel.
4. Close the access door.

**Figure 3-6: RA82 Air Filter Removal**

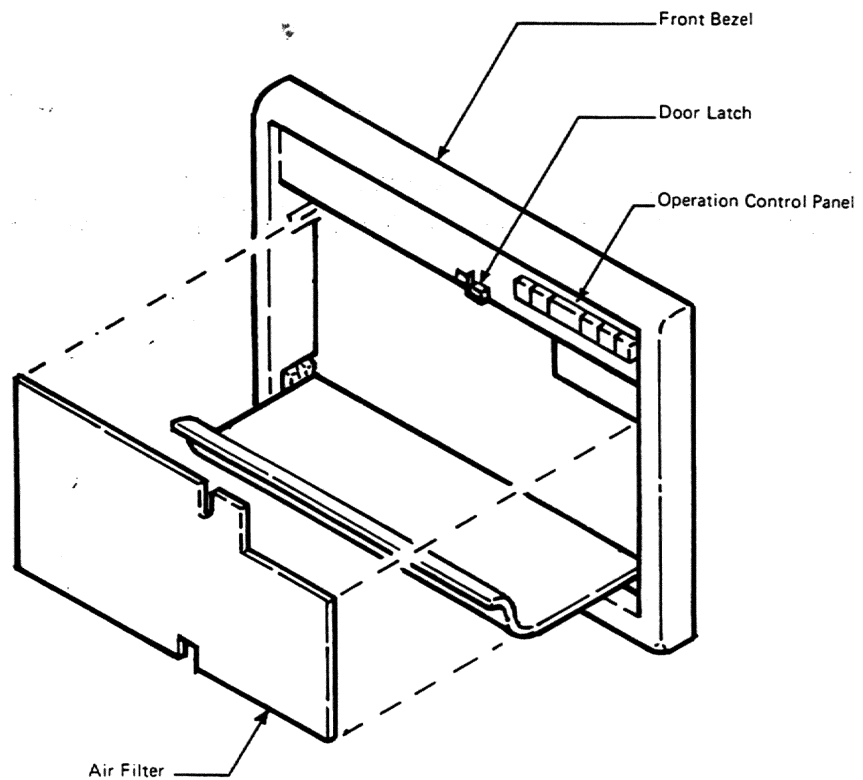

ML0-1227-87

### **3.1.2 TK70 Tape Drive**

The TK70 tape drive is located behind the sliding window in the front of the system. To use the drive, move the key to the middle or bottom position and slide down the window.

The TK70 tape drive holds one removable magnetic tape cartridge. The drive can read data written on either a COMPACTape II or COMPACTape cartridge. You can identify the type of cartridge by the label on the cartridge. The COMPACTape II has a blue label strip.

You can use a COMPACTape II or COMPACTape cartridge as an input device to load software or data into your system. The TK70 drive can read data on both types of cartridges, written by either a TK70 drive or a TK50

drive. (The TK50 drive records data in a format different from that of the TK70.)

You should use a COMPACTape II as an output device to make copies or backups of software or data. The TK70 drive cannot write to a COMPACTape II or COMPACTape that has been written by a TK50 tape drive.

The tape drive has two primary controls: the cartridge insert/release handle (subsequently referred to as "the handle") and the Unload button. You use the handle to insert or remove cartridges and lock them into position. Pull the handle open to insert or remove a tape cartridge. Push the handle closed to lock a tape cartridge into position and load the tape.

You use the Unload button to rewind and unload the tape. Unloading and rewinding can also be controlled by software. Refer to your system software manuals for appropriate commands.

The TK70 tape drive also has three indicator lights that tell you the status of the drive.

- **Orange light (Write-Protected):** A steady orange light indicates that the cartridge is write-protected.
- **Yellow light (Tape in Use):** A steady yellow light indicates that the tape is loaded. A blinking yellow light indicates that the tape is in motion.
- **Green light (Operate Handle):** A steady green light indicates that you can move the handle to insert or remove a tape. A blinking green light indicates a cartridge load fault. You can also move the handle when the green light is blinking.
- All three lights blinking simultaneously indicate a fault condition.

Figure 3-7 shows the TK70 tape drive with the controls and indicator lights labeled.

**Figure 3-7: TK70 Tape Drive**

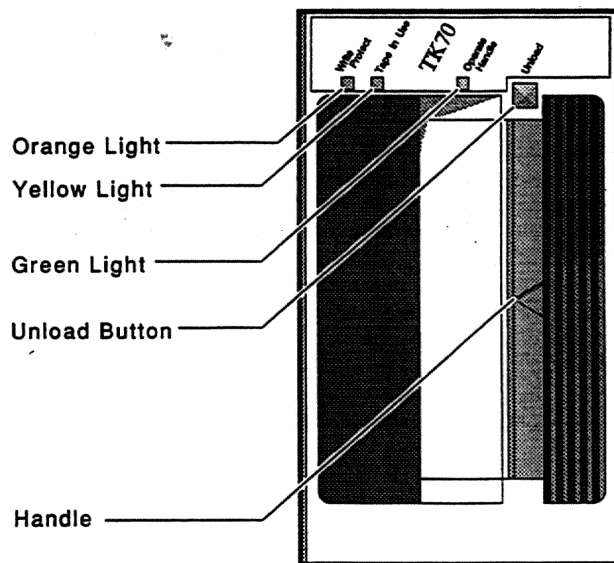

MLO-002292

To operate the drive properly, you must carefully monitor the indicator lights. The instructions for inserting and removing cartridges, which appear later in this section, tell you what should happen at each step. A table at the end of the section summarizes light and control combinations.

### 3.1.2.1 Design of the Drive

The TK70 tape drive operates somewhat like a reel-to-reel tape deck. Inside the drive is a take-up reel with a leader attached. Inside the cartridge is a single reel containing the magnetic tape. When you insert the cartridge and push in the handle, the leader in the drive automatically couples with the leader in the cartridge, and the tape winds onto the take-up reel. The coupling and winding process is called loading. When the automatic loading process is complete, the tape is ready to use.

Once the cartridge is loaded, you cannot remove it without rewinding and uncoupling the leaders, a process called unloading. Even if you have not used the tape, you must unload it before you can remove the cartridge. When you press the Unload button, the tape rewinds into the cartridge and the leaders uncouple.

### 3.1.2.2 Labeling a Tape Cartridge

When recording data on a cartridge, label its contents. For your convenience, a slot for the label is provided on the front of the cartridge. Write the identification on the label and insert the label in the slot on the front of the cartridge, as shown in Figure 3-8. The label is visible when the tape is in the drive.

**Figure 3-8: Labeling a Tape Cartridge**

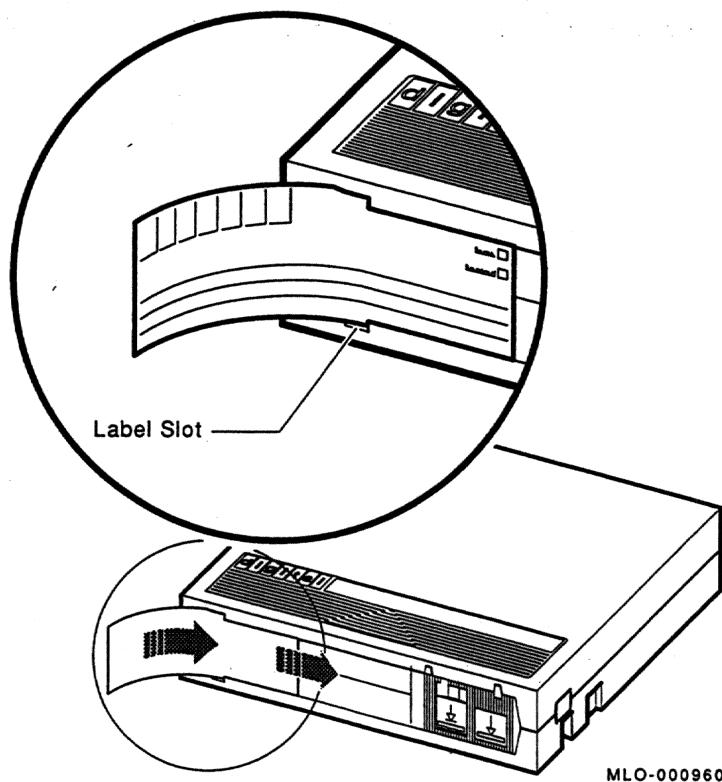

To indicate that the tape was recorded on a TK70 tape drive, check the box labeled 296MB. The 95MB box is used for tapes recorded on a TK50 drive.

**NOTE:** Do not write on the tape cartridge or attach labels to the top, bottom, or sides of the cartridge.

### 3.1.2.3 Write-Protecting a Tape Cartridge

Write-protecting a tape cartridge prevents accidental erasure of information stored on the tape. You can write-protect a tape cartridge in two ways:

- Set the write-protect switch on the cartridge to the write-protect position.
- Write-protect the cartridge by using operating system commands described in your system software manuals.

Your system can read information on the tape regardless of the position of the write-protect switch or whether writing is software disabled. However, the system cannot write data to the tape when the write-protect switch is set to the write-protect position, or when writing is software disabled.

When you use a cartridge to install software, make sure the cartridge is write-protected. Two icons on the switch indicate the write-protect status, as shown in Figure 3-9. An orange rectangle is visible when the switch is in the write-protect position. If you do not see an orange rectangle, slide the switch toward the label slot.

**Figure 3-9: Tape Cartridge Write-Protect Switch**

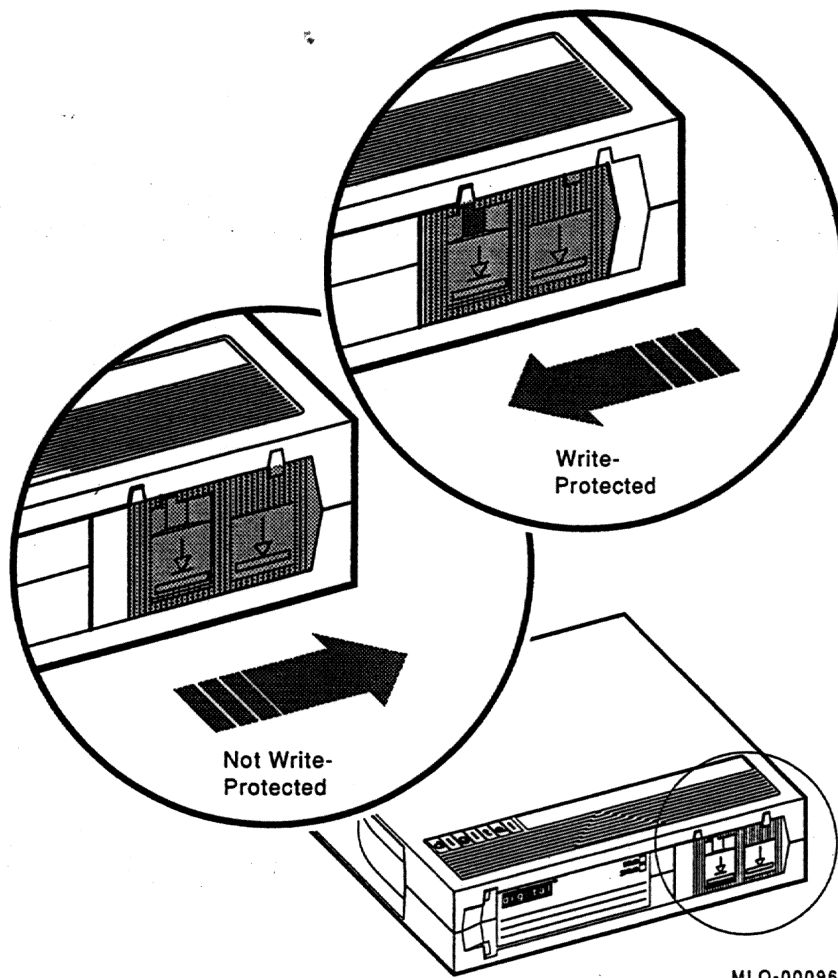

MLO-000961

When you insert a write-protected cartridge into the drive, the orange indicator light comes on. The system recognizes the tape as being write-protected under any one of the following conditions:

- The write-protect switch on the cartridge is set to the write-protect position.
- An operating system command has write-protected the tape.



- A tape recorded on a TK50 tape drive is inserted into the drive.

Removing write-protection depends on how the tape was recorded and how it is write-protected. You cannot write-enable a tape recorded on a TK50 tape drive either by moving the write-protect switch on the cartridge or by using software commands. The TK70 drive always recognizes a tape recorded on a TK50 drive as write-protected. You can remove write-protection on tapes recorded on a TK70 drive as follows:

- If the cartridge is write-protected *only* by the write-protect switch on the cartridge and not the operating system, moving the switch to the write-enabled position causes the orange light to go out at the end of the executing command.
- If the cartridge is write-protected *only* by a software command and not the write-protect switch, removing the operating system restriction causes the orange light to go out.
- If the cartridge is write-protected by *both* the switch on the cartridge and a software command, you must change the switch setting and remove the operating system restriction.

When you use a COMPACTape II cartridge to make a backup copy of files, make sure the orange write-protect light is off. If the light is not off, check for any of the write-protect conditions described above. Change the switch setting and/or operating system restriction as necessary. Do not begin your operation until the orange light goes off.

#### **3.1.2.4 Tape Cartridge Handling and Storage Guidelines**

- Do not touch the exposed surface of the tape.
- Do not drop the tape cartridge. The impact from a fall can damage the tape cartridge.
- Allow new tapes to stabilize at room temperature for 24 hours before using them.
- Place an identification label only in the label slot on the front of the tape cartridge.
- Store tape cartridges in a dust-free environment.
- Keep tape cartridges away from direct sunlight, heaters, and other sources of heat. Store tape cartridges in a stable temperature between 10° and 40° Celsius (50° and 104° Fahrenheit).
- Store tape cartridges where the relative humidity is between 20 and 80 percent.

- Keep tape cartridges away from magnets and equipment that generates magnetic fields, such as motors, transformers, terminals, and audio equipment.
- Keep tape cartridges away from x-ray equipment.

### 3.1.2.5 Inserting a Tape Cartridge

Before you use the tape drive, make sure the system is turned on (the power switch glows). During power-up, the TK70 drive runs self-tests that last a few seconds. All three lights (orange, yellow, and green) come on momentarily, then the yellow light blinks during the self-tests. At the end of the tests, the yellow light goes off and the green light comes on, accompanied by a short beep. The green light and the beep indicate that you can move the cartridge release handle.

**CAUTION:** *Move the handle only when the green indicator light is on. Moving the handle while the yellow light is on could damage the drive. If all three lights blink rapidly at any time, a fault condition exists. Press the Unload button once. If the fault is cleared, the tape unloads. The yellow light blinks during unloading, then the green light comes on. If the fault is not cleared, the three lights continue to flash. Do not attempt to use the tape drive or to remove the tape cartridge. Call your DIGITAL service representative.*

Use the following procedure to insert a tape cartridge (see Figure 3-10):

1. Pull the handle open.
2. Position the cartridge so the arrow on the cartridge faces left and points toward the drive. Insert the cartridge into the TK70 tape drive until you feel the cartridge lock into place.
3. Push the handle closed.

The green light goes off and the yellow light blinks as the tape loads. When the yellow light glows steadily, the tape is ready to use.

**NOTE:** *If the green light blinks rapidly when you push the handle closed, the drive has detected a cartridge fault. Pull the handle open and remove the cartridge. Use another cartridge.*

**Figure 3-10: Inserting a Tape Cartridge**

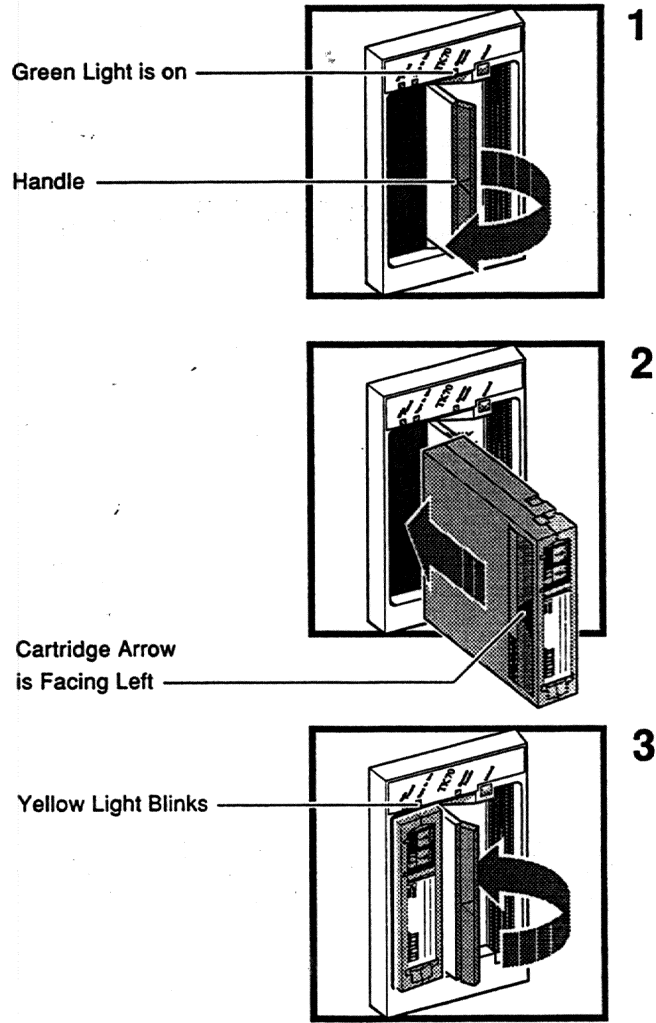

MLO-002459

Refer to your system software manual for instructions on how to use the tape cartridge, for example, how to load software or perform backup.

**NOTE:** *If a cartridge is new, the drive performs a calibration sequence that takes approximately 30 seconds when the drive receives the first command*

*from the operating system. The yellow light blinks rapidly and irregularly during calibration.*

### **3.1.2.6 Removing a Tape Cartridge**

You must unload a tape before you can remove the cartridge from the tape drive. Use the following procedure (see Figure 3-11):

1. Press the Unload button. You can also issue a software command to unload the cartridge. Refer to your system software manuals for the appropriate command.

The yellow light blinks slowly, as the tape rewinds and unloads into the cartridge. This may take up to 90 seconds.

2. When the yellow light goes off and the green light comes on (you also hear a beep), pull the handle open.

**CAUTION:** *Move the handle only when the yellow indicator light is off and the green indicator light is on. Moving the handle while the yellow light is blinking could damage the drive.*

3. Remove the tape cartridge and store it in its container.
4. Push the handle closed.

The green light remains on, indicating that there is power to the drive and that you can safely move the handle.

**CAUTION:** *Remove the tape cartridge from the tape drive when the cartridge is not in use or before you turn off the system. Failure to remove the cartridge may damage the tape cartridge.*

**Figure 3-11: Removing a Tape Cartridge**

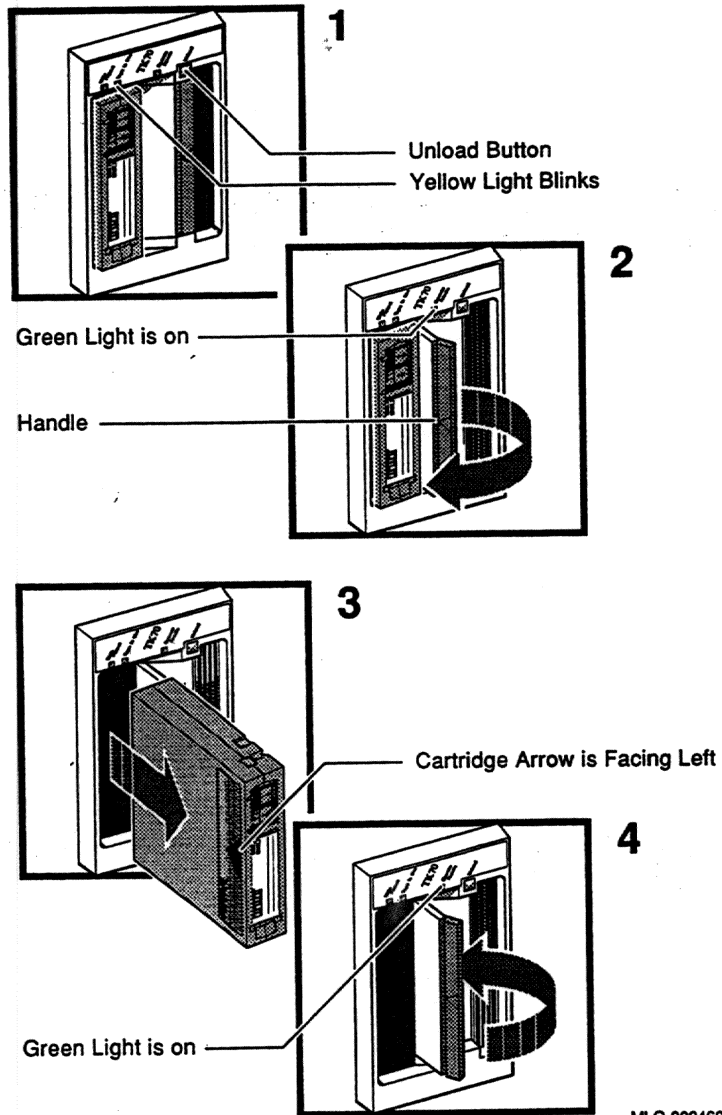

### 3.1.2.7 Summary of TK70 Tape Drive Controls and Indicator Lights

Table 3-3 summarizes the TK70 tape drive controls. Table 3-4 describes the meaning of the indicator lights.

**Table 3-3: TK70 Tape Drive Controls**

Control	Position	Function
Handle	Open	Lets you insert or remove a tape after rewind and unload operations are completed.
	Closed	Locks tape in operating position and begins load sequence.
Unload button	Momentary contact switch	Rewinds and unloads the tape.

**Table 3-4: TK70 Tape Drive Indicator Lights**

Orange	Yellow	Green	Condition
Off	Off	Off	No power to the tape drive.
Off	Off	On steadily	Safe to move cartridge release handle. Power is present.
Off	Off	Blinking	Load fault. The cartridge leader may be defective. Pull out the handle and remove the cartridge. Do not use the cartridge.
On/Off	On steadily	Off	Tape is loaded but not in motion.
On/Off	Blinking	Off	Tape is in motion.
On	On steadily/ blinking	On	Cartridge is write-protected.
Blinking	Blinking	Blinking	A fault is occurring. Press the Unload button to unload the tape cartridge. If the fault is cleared, the yellow light blinks while the tape rewinds. When the green light comes on, you can move the handle to remove the cartridge. If the fault is not cleared, all three lights continue to blink. Do not attempt to remove the tape cartridge. Call your DIGITAL service representative.

### 3.1.3 TSV05 Tape Drive

The TSV05 reel tape drive provides 40 Mbytes of storage for backup of data. The drive is mounted in an auxiliary cabinet, as shown in Figure 3-12.

**NOTE:** *The TSV05 is a data interchange device and is not supported as a backup device.*

**Figure 3-12: TSV05 Tape Drive Controls and Indicators**

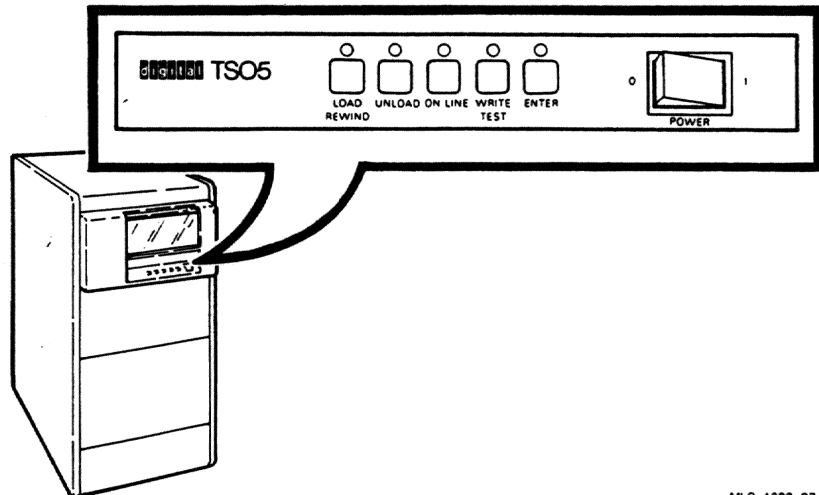

MLO-1233-87

#### 3.1.3.1 Controls and Indicators

The TSV05 tape drive has an on/off power switch and five switches, each with an indicator light. When the drive is powered on, all indicators light for approximately two seconds. When all the indicators except the UNLOAD indicator go out, the tape unit is ready to be loaded. Figure 3-12 shows the controls and indicators used to operate the drive.

Each control has an associated indicator light. Table 3-5 lists the functions of the controls and indicators.

**Table 3-5: TSV05 Tape Drive Controls and Indicators**

---

<b>Control/Indicator Function</b>	
<b>LOAD/REWIND</b>	<p><b>Control</b>—Starts load sequence and advances tape to load point. Rewinds the tape to load point.</p> <p><b>Indicator</b>—Blinks when the tape drive is executing a load or rewind sequence. Lit continuously when the beginning of tape (BOT) marker is sensed.</p>
<b>UNLOAD</b>	<p><b>Control</b>—Causes the tape to be unloaded regardless of tape position.</p> <p><b>Indicator</b>—Blinks when the tape drive is executing an unload sequence.</p> <p>Lit continuously when the tape drive has completed its unload sequence and the front access door is unlocked. At this time, the tape may be removed and another tape inserted into the drive.</p> <p>Lit continuously after a successful power-up, indicating a tape may be loaded.</p>
<b>ON LINE</b>	<p><b>Control</b>—Places the tape drive off-line and extinguishes the indicators.</p> <p>Places the tape drive on-line and lights the indicators.</p> <p><b>Indicator</b>—Lit when the drive is ready and on-line.</p>
<b>TEST</b>	<p><b>Control</b>—Operational only in the test mode. Selects alternative operational modes for other switches. For the use of qualified service personnel only.</p>
<b>WRITE</b>	<p><b>Indicator</b>—Lit when the write-enable ring is installed and data may be written on the tape.</p> <p>When indicator is off, write-enable ring is not installed and tape is write-protected.</p>
<b>ENTER</b>	<p><b>Control</b>—Used for manual loading, and controlling the test mode. For qualified service personnel only.</p>

---

### **3.1.3.2 Inserting Write-Enable Ring**

Before mounting the reel of tape onto the supply hub, determine whether or not write operations are to be performed on the tape. If write operations are to be performed, place a write-enable ring into the recess (groove) in the bottom of the reel, as shown in Figure 3-13. When the reel is prepared, proceed with loading the tape.



**Figure 3-13: Inserting Write-Enable Ring (TSV05 Tape Reel)**

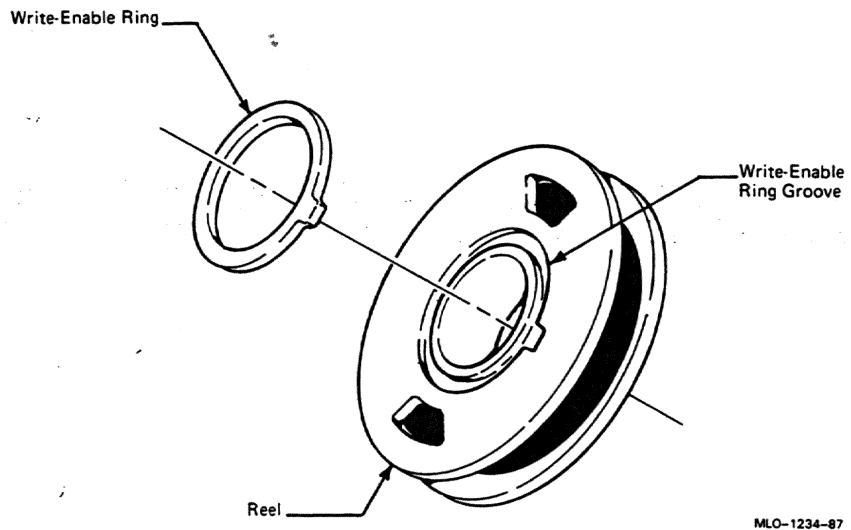

### 3.1.3.3 Loading Tape

Load the tape as follows:

**NOTE:** *Most tape reels have some form of stick-on tab or rubber block to prevent the tape from unwinding during shipment or storage. Remove these items so the tape leader is free to unwind during the autoloading sequence.*

1. Make sure the tape is wound completely onto the reel, and the write-enable ring, if present, is fully seated.
2. Open the front door by gently pressing down on the top center of the door.
3. Hold the tape reel with the write-enable ring side down. Insert the reel into the drive, centering it on the hub. (See Figure 3-14.)
4. Close the front door.
5. Press the LOAD/REWIND switch. This locks the cover and the door, and begins the loading sequence.
6. The LOAD indicator blinks while the tape is being loaded. Typically after 30 seconds, the LOAD indicator stops blinking and remains lit. This indicates that the tape is loaded and the tape drive is ready to use.

7. Press the ON LINE switch to place the tape drive under the control of the host computer. The ON LINE indicator lights when the TSV05 is on-line.

**Figure 3-14: Loading the TSV05 Tape Drive**

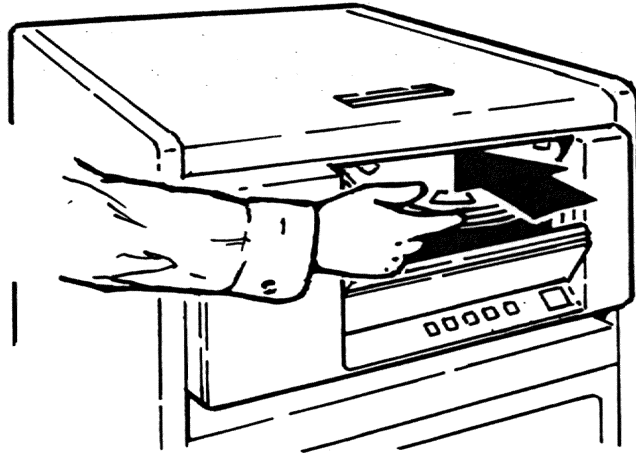

MLO-1235-87

#### **3.1.3.4 Rewinding Tape**

During normal operation, you do not need to rewind the tape, as tape movement is under program control. However, under unusual circumstances, such as a host system failure or a loss of communications with the host, you may wish to rewind the tape under local control. Rewind the tape as follows:

1. If the tape drive is on-line (ON LINE indicator is lit), press the ON LINE switch once to place the drive off-line.
2. Press the REWIND switch. The LOAD/REWIND indicator blinks while the tape is being rewound, then remains on continuously when the beginning-of-tape (BOT) is reached.

### **3.1.3.5 Unloading Tape**

To unload a tape from the drive, do the following:

1. If the tape drive is on-line (the ON LINE indicator is lit), press the ON LINE switch once to place the drive off-line.
2. Press the UNLOAD switch. The UNLOAD indicator blinks while the tape unloads. When the unloading process is complete, the UNLOAD indicator lights continuously, and the front door is unlocked. A typical unload sequence from BOT takes 15 seconds.
3. Open the front door and lift the tape reel out of the tape drive.
4. Close the front door.

### **3.1.3.6 Restarting the Tape Drive**

The TSV05 shuts down when there is a power failure, or when it detects a hard error condition. You may need to restart the system in either of these cases.

When power is interrupted, the drive automatically shuts down and tape motion stops without any damage to the tape. When power is restored, the TSV05 powers up in the Unload mode. You must press either the LOAD or the UNLOAD switch, depending on what you want to do with the tape. Follow the instructions in the previous sections for loading or unloading the tape.

When the TSV05 encounters an error condition from which it cannot automatically recover, it stops tape movement and displays a series of blinks on the indicators. If this happens, switch off the TSV05 power, switch it back on again, and then press the UNLOAD switch. After the UNLOAD indicator stops blinking, remove the tape and call your DIGITAL service representative.

The *MicroVAX Troubleshooting and Diagnostics* manual lists other actions you may take if your tape drive does not operate as described.

### **3.1.3.7 Care of Magnetic Tapes**

To avoid damage to the tape or drive, use the following guidelines when handling or storing tapes:

- Do not expose tapes to dust or excessive heat.
- Always store tape reels inside containers when the tape is not in use.
- Never touch the portion of tape between the beginning-of-tape (BOT) and end-of-tape (EOT) markers; oil from fingers attracts dust and dirt.

- **Never use a contaminated reel of tape; this spreads dirt to the clean tape reels and could adversely affect tape drive reliability.**
- **Always handle tape reels by the hub hole; squeezing the reel flanges leads to tape edge damage when winding or unwinding tapes.**
- **Always store tape reels where the relative humidity is between 20 and 80 percent.**
- **Do not smoke near the tape drive or storage area; smoke and ash are especially damaging to tapes.**
- **Do not place magnetic tape near line printers or other devices that produce paper dust.**
- **Do not place magnetic tape on top of the tape drive or in any other location where it may be affected by hot air.**
- **Do not store magnetic tape near electric motors.**

### 3.1.4 TU81-Plus Tape Drive

The TU81-Plus reel tape drive provides 140 Mbytes of storage (in high-density mode) for backup of data. The drive is mounted in the top of an auxiliary cabinet, as shown in Figure 3-15.

Figure 3-15: TU81-Plus Tape Drive Controls and Indicators

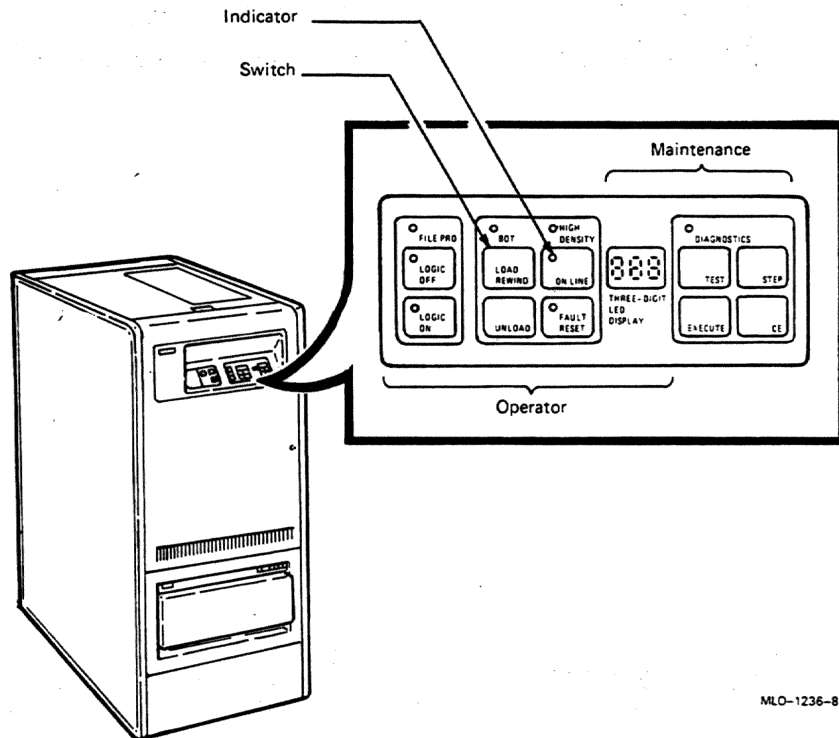

MLO-1236-87

#### 3.1.4.1 Controls and Indicators

Controls and indicators on the TU81-Plus control panel are grouped by function into service, operator, and maintenance use. The left part of the control panel provides special-purpose switches, connectors, and indicators for use by DIGITAL service representatives. Part of the service control panel is behind a small hinged door. Figure 3-15 shows the operator and maintenance portions of the control panel.

The operator portion of the control panel contains switches, indicator lights, and a LED display. The three-digit display shows the unit number during

normal operation. If an error occurs, either during on-line operation or off-line diagnostic routine, the display indicates a three-character error code. While running the off-line resident diagnostic, the display shows the number of the test in progress.

The maintenance portion of the panel contains the switches and lights for running the resident diagnostic test routines. These test routines are described in TU81-Plus documentation.

Table 3-6 summarizes the operator controls.

**Table 3-6: TU81-Plus Tape Drive Operator Controls and Indicators**

<b>Control/Indicator</b>	<b>Function</b>
LOGIC OFF	Indicator—When lit, LOGIC OFF indicates a power fault condition. The tape drive power supply has failed.
LOGIC ON	Indicator—When lit, LOGIC ON indicates a normal power-on condition with all dc voltages applied to the drive's control system and circuits.
BOT	Indicator—When lit, indicates tape is positioned at beginning-of-tape (BOT) marker.
LOAD/REWIND	Switch—If the drive is powered on, and a tape is threaded, pressing this switch causes a load operation to be performed. If a tape is loaded, pressing LOAD/REWIND causes a rewind operation to BOT.
UNLOAD	Switch—If tape is loaded at BOT, pressing UNLOAD causes the tape to unload from the take-up reel onto the supply reel. If the tape is loaded beyond BOT, it rewinds to BOT. If the tape is threaded, but not loaded, pressing UNLOAD causes the drive to slowly unload the tape onto the supply reel.
ON LINE	Switch—If the tape is loaded, pressing ON LINE causes the drive to go on-line and become accessible to the host system. Pressing RESET places the drive off-line.  Indicator—When lit, indicates that the TU81-Plus is on-line. All switches except RESET are disabled.
FILE PRO	Indicator—When lit, indicates absence of a write-enable ring. Write operations are not allowed.
HIGH DENSITY	Indicator—When lit, indicates that the transport is selected by the host system for Group Code Recording (GCR) operation.

**Table 3-6 (Cont.): TU81-Plus Tape Drive Operator Controls and Indicators**

<b>Control/Indicator</b>	<b>Function</b>
<b>RESET</b>	Switch—When pressed, RESET places the drive off-line, stops tape motion, and clears error status. The switch can stop a load or rewind operation. It also turns off the RESET indicator and clears diagnostic test conditions.
<b>FAULT/RESET</b>	Indicator—When lit, indicates that the drive is in a fault or diagnostic status. A 3-digit display may contain a fault or diagnostic code.

### 3.1.4.2 Inserting Write-Enable Ring

Before mounting the reel of tape onto the supply hub, determine whether or not write operations are to be performed on the tape. If write operations are to be performed, place a write-enable ring into the recess (groove) in the bottom of the reel, as shown in Figure 3-16. When the reel is prepared, proceed with loading the tape.

**Figure 3-16: Inserting Write-Enable Ring (TU81 Tape Reel)**

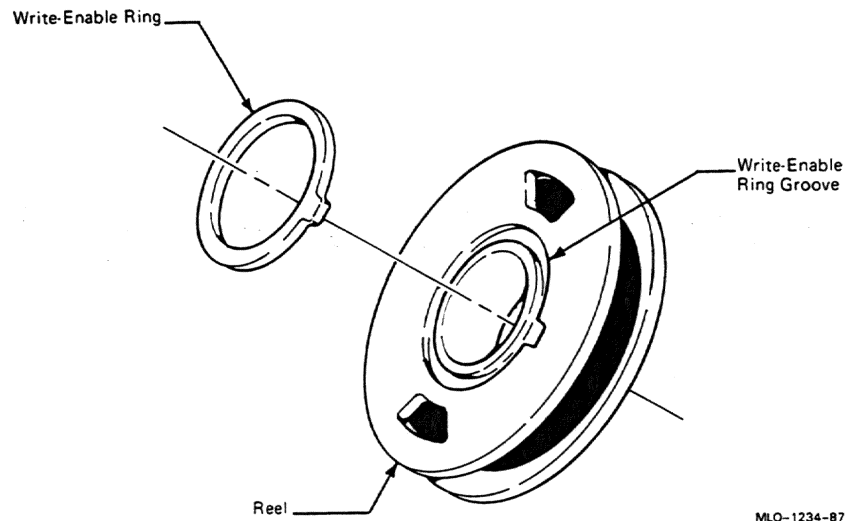

MLO-1234-87

### 3.1.4.3 Tape Threading and Loading

Before threading and loading the tape, you must open the top cover of the drive. Pull the cover latch toward the front and lift the top access door. Refer to Figure 3-17.

**Figure 3-17: Opening the TU81-Plus Cover**

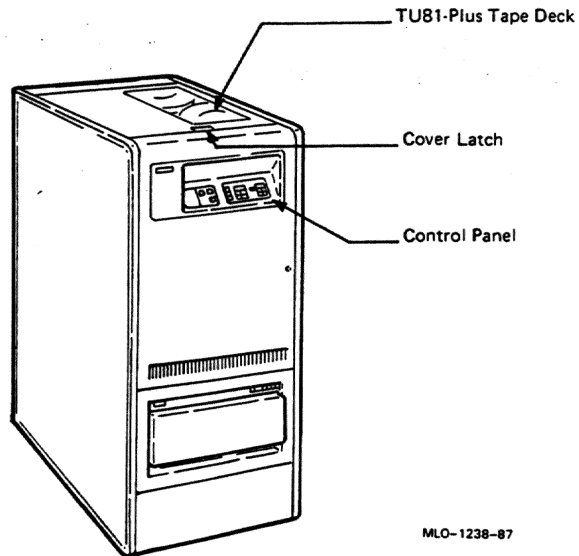

MLO-1238-87

Refer to Figure 3-18 and Figure 3-19 as you follow the steps for threading and loading the tape.



**Figure 3-18: TU81-Plus Tape Deck**

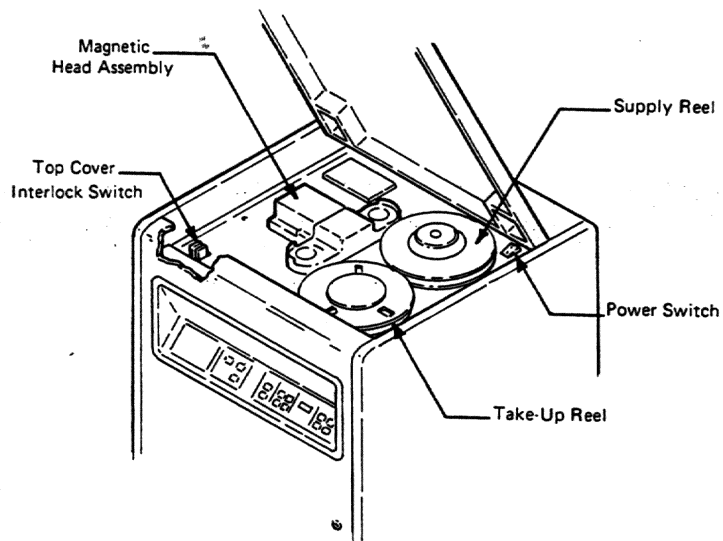

MLO-1239-87

**Thread and load a tape as follows:**

- 1. Make sure the power switch on the drive is set to 1 (on).**
- 2. Press the center button on the face of the supply-reel hub.**
- 3. Mount the supply reel onto the hub so that the reel is seated on the bottom flange. Secure the reel by pressing the periphery of the hub face to latch the reel.**
- 4. Thread the tape through the tape path, as shown in Figure 3-19.**

**Figure 3-19: Tape Path**

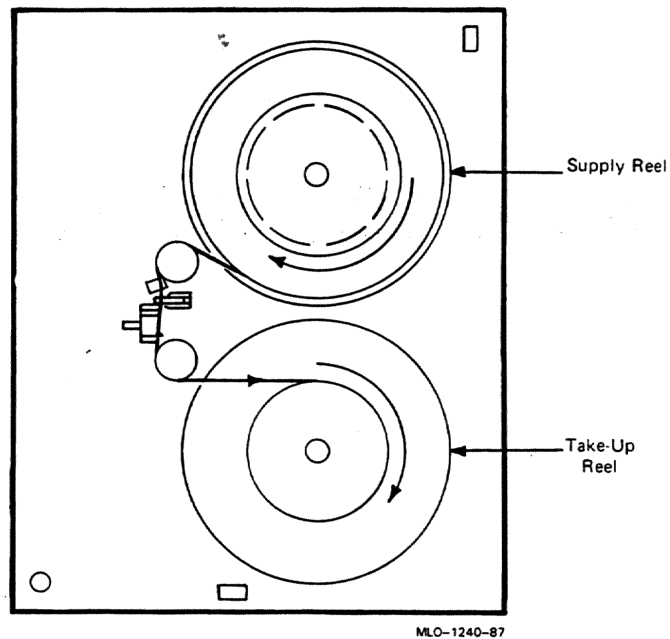

5. Wrap the tape leader onto the take-up reel for several turns. Make sure you do not wrap the BOT marker (a pressure-sensitive foil label that indicates the beginning-of-tape to the drive) onto the reel.

**CAUTION:** *Make sure the tape is positioned correctly over all tape path components; otherwise, tape damage may occur.*

6. Close and latch the top cover.
7. Press the LOAD/REWIND switch. In one second, air pressure builds at the air bearings and the tape starts moving forward. This motion stops when the BOT marker on the tape is detected. When the BOT marker is detected, the BOT indicator is lit. If the drive does not detect the BOT after 40 feet of tape, it reverses itself until the BOT marker is detected.

**NOTE:** *If LOAD fails and the tape does not move to BOT, check for the BOT marker on the tape. If the marker is missing, attach a new one.*

8. Press the ON LINE switch to make the drive available to the host. You can press ON LINE while a load operation is in progress. When the load operation is complete, the ON LINE indicator comes on. The drive is ready for use.

#### 3.1.4.4 Tape Unloading

Generally, tapes are unloaded by a software command when the drive is on-line to a host. However, you can unload the drive manually as follows:

1. Press the FAULT/RESET switch to place the drive off-line.
2. Press the UNLOAD switch. The tape rewinds onto the supply reel. If the tape is loaded beyond the BOT marker, the tape rewinds to BOT and the BOT indicator comes on. Press UNLOAD again to wind the tape onto the supply reel. If the tape is at BOT (the BOT indicator is lit) press UNLOAD to wind the tape onto the supply reel. If the tape is threaded but not loaded, press UNLOAD to wind the tape onto the supply reel.
3. Open the top cover and press the center button of the supply-reel hub. The hub unlatches and you can remove the supply reel.
4. Close the top cover to prevent dust accumulation on the tape deck components.

#### 3.1.4.5 Fault Codes Corrective Actions

If a fault condition occurs, the RESET indicator on the control panel comes on and a fault code displays. Refer to Table 3-7 for the appropriate action to take.

**Table 3-7: TU81-Plus Fault Codes and Corrective Actions**

<b>Fault Code</b>	<b>Corrective Action</b>
E01-E09	Clean magnetic head and tape path.
E10	Ensure the top cover is securely closed.
E11	Thread tape.
E12	Latch supply reel hub.
E13	Thread tape correctly as shown in Figure 3-19.
E14	Check for BOT marker on tape. Attach BOT/EOT marker.
E15	Indicates the RESET switch was pressed inadvertently by the operator. Reinitiate test.

**Table 3-7 (Cont.): TU81-Plus Fault Codes and Corrective Actions**

<b>Fault Code</b>	<b>Corrective Action</b>
E16	Check for the presence of write-enable ring in supply tape reel. Install the ring if not present.
E17	Check for presence of EOT marker. Attach EOT marker.
E18	Indicates that the tape was loaded when the test was initiated. Thread the tape, but do not press the LOAD switch.
E20-E29	Mount a tape of known good quality.
All others	Report the fault code to your DIGITAL service representative.

## **3.2 Communications Controller Options**

The following types of communications controllers are available for the MicroVAX 3900 and VAXserver 3900 systems:

- Asynchronous serial controllers (with or without modem support)
- Synchronous serial controllers (with or without modem support)
- Network controllers

### **3.2.1 Asynchronous Serial Controllers**

The following asynchronous controllers are available for your MicroVAX system, with and without modem support:

- CXA16—16-line multiplexer, Q-bus controller
- CXB16—16-line multiplexer
- CXY08—8-line multiplexer with modem control, Q-bus controller
- DFA01—2-line controller with integral modems, Q-bus controller
- DSRVB—8-line terminal server, Ethernet device

#### **3.2.1.1 Without Modem Support**

Before using any peripheral device connected to a serial communications controller, check the following:

- Make sure the peripheral device is properly connected to the system.
- Make sure the peripheral device is properly installed, plugged into an appropriate power source, and turned on.

- Make sure the peripheral device is properly set up. Set-up involves choosing how the device operates. Some set-up choices are matters of personal choice, for example, the number of columns that display on a terminal screen. Others, like baud rate (a measure of the speed at which data is transmitted over a data line), must match the system setting if the peripheral device and system are to communicate. Refer to your terminal or printer manual for complete set-up instructions. Generally, the default settings for your terminal are acceptable.

While most default settings are acceptable, you should perform the set-up procedure for your terminal to ensure appropriate set-up values. The two examples below provide set-up instructions for VT300-series and VT200-series terminals:

#### **For VT300-Series Terminals:**

1. Press **[Set-Up]** to display the Set-Up Directory screen.
2. Use the arrow keys to select the "Communications Set-Up" option and press **[Enter]**.
3. Make sure the "Transmit Speed" option in the "Current Setting" column is set to 9600. Use the left and right arrow keys to change the setting.
4. Make sure the "Receive Speed" option in the "Current Setting" column is set to "receive=transmit." Use the down arrow to move the cursor to this option, and the left and right arrows to change the setting.
5. Press **[Select]** to return to the Set-Up Directory screen.
6. Use the arrow keys to select the "Global Set-Up" option and press **[Enter]**.
7. Select the option "Comm Port."
8. If the port in the "Current Setting" column is selected for "RS-232," press **[Enter]** to select the "DEC-423" port.
9. Press **[Select]** to return to the Set-Up Directory screen.
10. Use the arrow keys to select the "Save Current Settings" option. Press **[Enter]** to save all current settings; then press **[Set-Up]** to exit the Set-Up Directory.

#### **For VT200-Series Terminals:**

1. Press **[Set-Up]** to display the Set-Up Directory screen.

2. Use the arrow keys to select the "Default" option and press **[Enter]**. Default correctly sets all values except transmit speed.
3. Use the arrow keys to select the "Comm" option and press **[Enter]** to display the Communications Set-Up menu.
4. Use the arrow keys to select the "Transmit" option and, using **[Enter]**, set the speed to 9600.
5. Use the arrow keys to select the "To Directory" option and press **[Enter]**.
6. Use the arrow keys to select the "Save" option and press **[Enter]**; this option stores the set-up values. Then press **[Set-Up]** to exit the Set-Up Directory.

Your operating system may have other requirements for using serial communications devices. Refer to your system software manual.

### 3.2.1.2 With Modem Support

Using serial devices with modem support requires that you install two modems: one connected to the system and one connected to the remote terminal. Both must be connected to phone lines.

Before using modems with your system, check the following:

1. Make sure each modem is connected to the system.
2. Make sure the modem is properly installed and connected to a phone jack.
3. Set controls on the modem according to instructions in the modem user's guide.

Before using the modem connected to the remote terminal, check the following:

1. Make sure the modem is properly installed and connected to a phone jack.
2. Set controls on the modem according to instructions in the modem user's guide.
3. Check the settings on the terminal attached to the modem. Depending on the type of modem and the type of lines used, the baud rate may be 300, 1200, or 2400. Other settings should be the same as those described in the previous section.

Before using a phone line with modem support, you must set certain parameters such as line speed. See your system software manuals for details.

### 3.2.2 Synchronous Controllers

The following synchronous controllers are available for your MicroVAX system:

- DPV11—Single-line programmable controller
- DHV11—Dual-line controller
- KMV1A—Programmable communications interface, Q-bus controller

Before using a synchronous controller you must verify the following:

- The system you want to communicate with has an appropriate synchronous controller. Synchronous communications require a synchronous controller on both the transmitting and receiving system.
- Both the transmitting and receiving systems must have supporting host software installed. Synchronous communications operate under specific protocols that define how data is interpreted. Two common protocols are X.25 and PSI. Appropriate host software is required to interpret the protocol.

### 3.2.3 Network Controllers

Before using a network controller you must do the following:

1. Make sure the Ethernet cable (either standard transceiver cable or ThinWire cable) is connected to the DESQA module.
2. Make sure the Ethernet cable is properly connected to the network. A transceiver cable can be connected in one of the following ways:
  - To an H4000 transceiver located on a traditional Ethernet
  - To a Local Network Interconnect (DELNI), which can be connected to a larger Ethernet or can serve to connect up to eight systems in a local area network

A ThinWire cable can be connected as follows:

- To a ThinWire Ethernet Multiport Repeater (DEMPR) or ThinWire Singleport Repeater (DESPR), which can be connected to a larger Ethernet or can serve to connect many systems in a local area network
  - To an available connection on a T-connector of other ThinWire nodes
3. Have the DECnet application installed on your system.

4. Register your node with the network manager so that your node is recognized by other systems in the network.

Some software products, for example, Ethernet-based VAXcluster systems, use the Ethernet hardware address of other systems to operate properly.

To find the hardware address of your Ethernet device, open the front door of your system. The hardware address of your Ethernet device is printed on the DESQA Ethernet adapter module.

You can also use the command `SHOW ETHER` from console I/O mode. The hardware address of your Ethernet device displays on the terminal as shown in the following example:

```
>>>SHOW ETHER
```

```
08-00-2B-03-50-5C
```

Refer to your software manuals and DECnet manuals for other requirements and further instructions on using a network connection.

### 3.3 Real-Time Options

The following real-time options are available for your MicroVAX system:

- DRQ3B—High-speed interface with two unidirectional 16-bit data channels
- DRV1W—General purpose interface with one 16-bit input port, one 16-bit output port
- IEQ11—DMA controller that connects a Q-bus to two independent buses
- IBQ01—DMA controller that connects a Q-bus to RS-485 control
- AAV11-S—Digital-to-analog converter with DMA capability
- ADV11-S—Analog-to-digital converter with DMA capability
- KVV11-S—Programmable clock that can count from one to five frequencies
- AXV11—Input/output circuit board for analog devices
- ADQ32—Analog-to-digital converter with DMA capability

Before using a real-time controller, make sure the devices connected to the controller are properly set up. Refer to the documentation for the real-time device.



### 3.4 Printer Options

Before using a printer, make sure it is properly set up and passes any self-tests. Verify that the printer is connected to an appropriate controller. Some printers, such as the LG01 and LG02, require the LPV11-SA interface. Other printers require modem control signals. Consult your printer documentation for the interface requirements.

The MicroVAX 3900 and VAXserver 3900 systems have several printer options available. Consult the *MicroVAX 3800/3900 VAXserver 3800/3900 Technical Information* for a list of printers and printer interface requirements.

### 3.5 Adding Options

If you have available slots, you may be able to add new modules to your system. Possible limitations to adding new modules include the following:

- Power limitations
- Physical space limitations
- Bus limitations (ac/dc loading)

Your DIGITAL sales representative can advise you about modules available for your system and what you need to order. A DIGITAL service representative should perform the installation, since the system must be properly configured to work correctly.

**CAUTION:** *Do not attempt to remove, rearrange, or install new modules. Contact a DIGITAL service representative for assistance.*

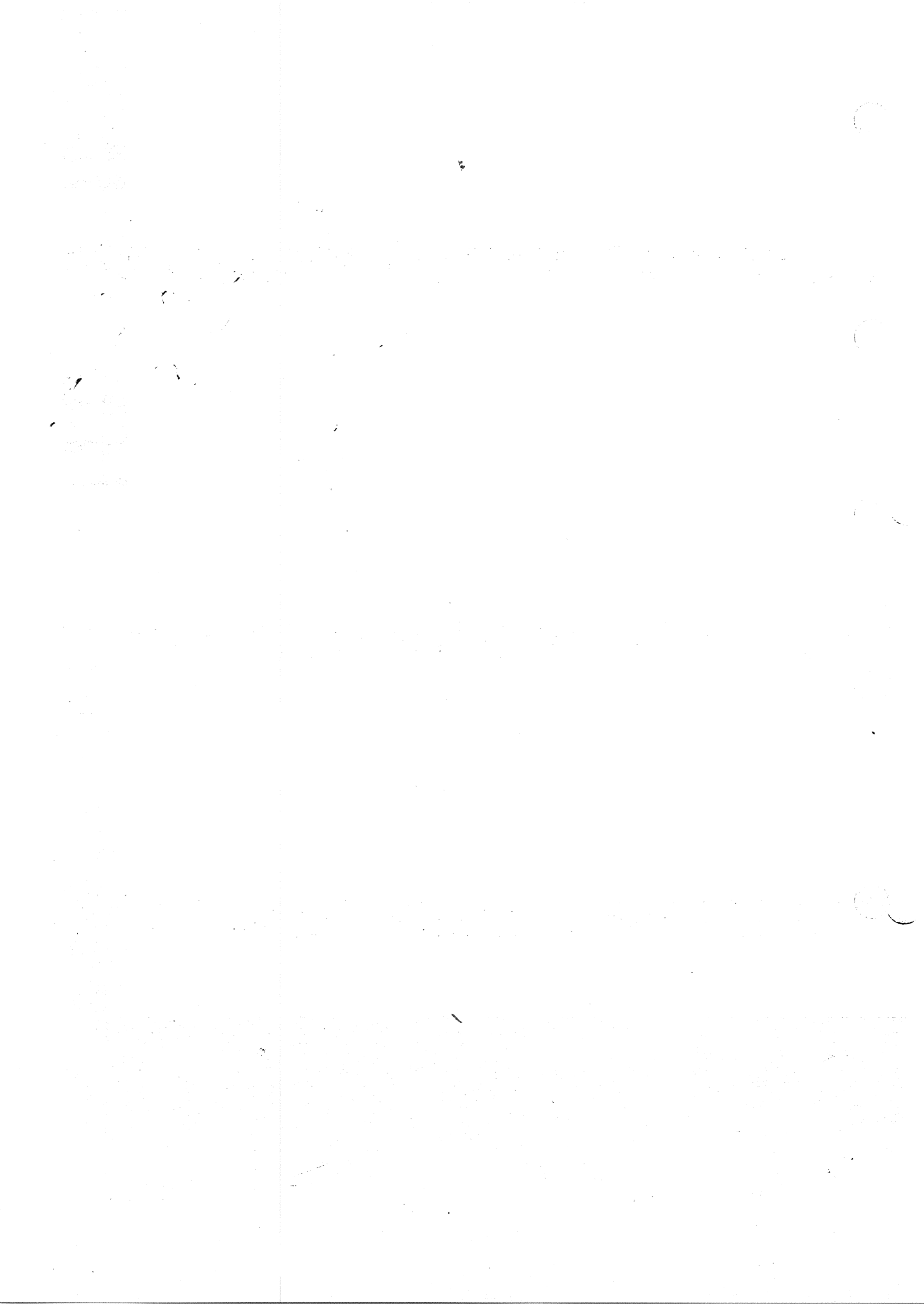

## Appendix A

# Related Documentation

Document	Order Number
<b>Hardware Documentation</b>	
KA655 CPU Systems Maintenance	EK-306AA-MG - 533 F
KA655-AA CPU Module Technical Manual	EK-KA655-TM - 556 F
RA90 Disk Drive User Guide	EK-ORA90-UG
TSV05 Tape Transport System User's Guide	EK-TSV05-UG
<b>Software Documentation</b>	
Overview of VMS Documentation	AA-LA95A-TE
VAXELN Host System Guide	AA-JG87B-TE
VAXELN Run-Time Facilities Guide	AA-JM81B-TE
ULTRIX-32 Basic Installation Guide	TBD
<b>Microcomputer Handbook Series</b>	
VAX Architecture Handbook	EB-19580-20
VAX Software Handbook	EB-21812-20
Microcomputer Interfaces Handbook	EB-20175-20
Microcomputers and Memories Handbook	EB-18451-20

Documentation specific to supported options is listed with the option in *MicroVAX 3800/3900 VAXserver 3800/3900 Technical Information*.



# Glossary

---

**Application program**

A program designed to meet specific user needs, such as a program that monitors a manufacturing process.

**Backplane**

1. The connector block that printed circuit boards plug into.
2. A printed circuit board containing the bus.

**Back up**

The process of making copies of the data stored in your disk drive(s) so that you can recover that data after an accidental loss. You make these copies on a tape cartridge and then store it in a safe place.

**Backup copy**

A duplicate copy of data on your fixed disk that is stored on a tape cartridge.

**Baud rate**

The speed at which signals are transmitted serially along a communication line.

**Binary**

A number system that uses only two digits: 0 and 1. These digits are usually represented in circuitry by two voltage levels.

**Bit**

A binary digit, the smallest unit of information in a binary system of notation, designated as a 0 or a 1.

**Boot**

To use a bootstrap program to start a computer system.

**Bootable medium**

A fixed disk or magnetic tape containing software (such as an operating system) that the bootstrap program can load into the system memory.

**Bootstrap**

A program that you start when you turn on the system. The bootstrap loads software contained on a fixed disk or magnetic tape cartridge into memory. The system then stops executing the bootstrap and starts executing the software in memory. The software usually loads an operating system or other software into memory, so that the system can start processing.

**Bug**

An error in the design or implementation of hardware or software system components.

**Bus**

The connection between the central processing unit (CPU) and input/output devices in the system. Information signals such as, address, data, and control signals are carried through the bus.

**Byte**

A group of eight binary digits (bits). A byte is one-half the size of a word and one-quarter the size of a longword.

**Central processing unit (CPU)**

The part of a computer system that controls the interpretation and execution of instructions.

**Command**

An order given by a user to a computer, often through a terminal keyboard.

**Communication line**

A cable along which electrical signals are transmitted. Systems or devices connected by communication lines can share information and resources.

**Computer system**

A combination of computer hardware, software, and external devices that performs specific operations or tasks.

**Console terminal**

The terminal you use when installing software and running diagnostic programs.

**Controller**

A component that regulates the operation of one or more peripheral devices. Controllers are often called interface units.

**CPU**

See *Central processing unit*.

**Data**

A representation of facts, concepts, or instructions, suitable for communication, interpretation, or processing by human beings or by machines.

**Data transmission**

The movement of data, in the form of electrical signals, along a communication line.

**Debug**

To detect, locate, and correct errors (bugs) in system hardware or software.

**Device**

The general name for any entity connected to a system that is capable of receiving, storing, or transmitting data.

**Device name**

The name by which a device or controller is identified within a system. You use the device name to refer to that device when communicating with the system.

**Diagnostic program**

A program that detects and identifies abnormal hardware operation. The MicroVAX Diagnostic Monitor software contains several diagnostic programs.

**Disk**

A flat circular plate with a coating on which data is stored magnetically in concentric circles (tracks).

**Disk drive**

A device that contains a fixed disk or one or more diskettes. The drive contains mechanical components that spin the disk or diskettes and move the read/write heads that store and read information on the surface of the disk or diskettes.

**EIA**

Electronic Industries Association.

**Error message**

A message displayed by the system to indicate it has detected an error or malfunction.

**File**

A collection of related information treated by the computer as a single item.

**Firmware**

Software instructions stored in a fixed form, usually in read-only memory (ROM). In a MicroVAX 3800 or VAXserver 3800 system, the power-on self-tests and bootstrap program are firmware.

**Formatted data**

Data laid out in a particular pattern to conform to a predetermined structure. The structure is dictated by the system software.

**Hardware**

The physical components—mechanical and electrical—that make up a computer system. Compare *Software*.

**Head**

The part of a fixed-disk drive, diskette drive, or tape drive that reads, records, and erases data. Also called read/write head.

**Input device**

A piece of equipment used to transfer data into the computer. A keyboard is an input device.

**Input/Output (I/O) device**

A piece of equipment that accepts data for transmission both to and from a computer. A terminal is an input/output device.

**Interactive**

The method of communicating with a computer system. You type a command at the keyboard, the system executes the command, and then responds with a message or prompts for another command.

**Interface**

A device or piece of software that lets different components of a computer communicate with one another.

**I/O**

Abbreviation for input/output.



**Kbyte**  
1024 bytes.

**LED**

Light-emitting diode. A LED on the CPU cover panel displays a hexadecimal countdown during the power-on sequence.

**Load**

1. To move software, usually from a peripheral device into memory.
2. To place a disk in a disk drive, or tape in a tape drive.

**Longword**

A group of 32 bits, equal to two words or four bytes.

**Magnetic tape**

A long strip of plastic coated with magnetic oxide, used for storing data. Often called magtape. The tape contained in a tape cartridge.

**Mbyte**

1,048,576 bytes.

**Memory**

The area where a computer finds the instructions and data it will process.

**Menu**

A displayed list of options. The list usually contains commands you can enter.

**Off-line**

Pertaining to equipment, devices, and events that are not under direct control of the computer system.

**Operating system**

A collection of programs that controls the overall operation of a computer and performs such tasks as:

- Assigning places in memory to programs and data
- Processing requests, scheduling jobs
- Controlling the operation of input and output devices

**Output device**

A device by means of which data can be extracted from a computer system; for example, a printer.

**Peripheral device**

Any device distinct from the central processing unit that provides it with additional memory storage or communication capability. Examples are disk and diskette drives, video terminals, and printers.

**Power-on sequence**

A series of ordered events that occurs when you supply power to a system by turning it on.

**Printer**

A peripheral device that provides paper copies of information stored in a computer.

**Program**

The complete sequence of instructions necessary for a computer to perform a task. See *Software*.

**Prompt**

A character(s) or word(s) that a computer displays to indicate it is waiting for you to type a command.

**Read-only memory (ROM)**

A memory that does not allow modification of its contents. The computer can use data in a ROM but cannot change it.

**Reboot**

To restart a computer system. Pressing the Reset button reboots the system.

**Record**

A set of related data that a program can treat as a unit. A file consists of a number of records.

**ROM**

See *Read-only memory*.

**Run**

1. A single continuous execution of a program.
2. To execute a program.

**Software**

Programs executed by a computer system to perform a chosen or required function. Compare *Hardware*.

**Software package**

A set of related programs that performs a specific task.

**Storage medium**

Any device capable of recording information, for example, a tape cartridge.

**Store**

To enter data into a storage device, such as a disk, or into memory.

**System**

A combination of computer hardware and software and external devices that performs specific processing operations.

**System management**

Tasks performed by the operating system to control the overall operation of the computer system.

**Terminal**

An input/output device generally used for communication between the users of a computer system and the system itself.

**Video terminal**

A terminal that displays information on the screen of a cathode ray tube (CRT).

**Word**

A word is 16 bits long.

**Write-protect**

To protect a disk, diskette, or other storage medium against the addition, revision, or deletion of information.



## A

---

- Air circulation, 1-18
- Autobooting the system, 2-5

## B

---

- Base system components
  - function, 1-24
- BOOT command
  - uses, 2-9
- Booting from console mode, 2-8
- Booting the system
  - autobooting, 2-5
  - from console mode, 2-8
- Break Enable/Disable switch, 1-15

## C

---

- Card cage
  - location, 1-12
  - slots, number of, 1-12
- Cartridge release handle, 3-14
- Central processing unit (CPU)
  - function, 1-25
- Chassis
  - front view, 1-10
- Circuit breaker
  - function, 1-17
  - location, 1-17
  - operation, 1-17
  - system, 1-24
- Communications controllers
  - asynchronous serial devices, 1-27
  - CXA16, 1-27
  - CXY08, 1-28
  - function, 1-26

- Communications controllers (cont'd.)
  - network devices, 1-27
  - set-up required, 3-39
  - synchronous serial devices, 1-27
  - types, 1-26, 3-38
  - using controllers with modem support, 3-40
  - using controllers without modem support, 3-38
  - using network controllers, 3-40
- Console terminal connector
  - function, 1-16
  - location, 1-16
- Cover panel
  - CPU, 1-14
  - labels, 1-14
  - types, 1-14
- CPU
  - See Central processing unit
  - location, 1-14
- CXA16
  - communications controller, 1-27
- CXY08
  - communications controller, 1-28

## D

---

- DC OK light
  - function, 1-17
  - on power supply, 1-11, 1-17
  - system, 1-11
- DELNI
  - connecting to an Ethernet cable, 3-41
- DESQA
  - before using, 3-41
- Disk drives
  - RA-series, 3-1

Door positions  
of front door, 1-4

---

## E

---

Error messages  
at power-on, 2-4

---

## F

---

Fans  
function, 1-18  
location, 1-18

Fixed-disk drives  
description, 1-26  
function, 1-26  
location, 1-11  
write-protect switches, 1-11

Front door  
description, 1-4  
opening, 1-8

---

## H

---

Halting the system, 2-10  
description, 2-10

---

## I

---

Indicator lights  
on TK70 tape drive, 3-14

Inserting a tape cartridge, 3-20

---

## K

---

KDA50  
controller, 1-26

---

## L

---

Labeling a TK70 tape cartridge,  
3-16

Language Inquiry Mode  
setting of Power-Up Mode switch,  
1-16

LED display  
on CPU cover panel, 1-16

Loading a TK70 tape cartridge,  
3-15

Loading system software  
with BOOT command, 2-9

Locking the window, 1-4

Loop Back Test Mode  
setting of Power-Up Mode switch,  
1-16

---

## M

---

Main memory, 1-25

Mass storage, 1-25  
controllers, 1-26  
devices, 1-25, 3-13  
options, 3-1

Mass storage shelf  
description, 1-11

Modems  
function, 1-27  
using, 3-40

Module identification labels, 1-14

---

## N

---

Network  
communications controllers,  
1-25, 1-28

New system  
using, 2-1

---

## O

---

Opening the window, 1-4

Optional devices  
adding to system, 1-28

Options  
adding, 1-28

---

## P

---

Pages and memory management,  
1-25

Power controller  
function, 1-22, 1-23

Power-on indicators  
normal, 2-4

Power-on self-tests  
description, 2-4  
Power supplies  
location, 1-16  
Power-Up Mode switch, 1-16  
Printers  
use of, 3-43

## R

---

RA60 disk drive controls, 3-7  
RA60 disk pack  
inserting, 3-9  
removing, 3-11  
RA70 disk drive controls, 3-7  
RA82 disk drive controls, 3-7  
RA90 disk drive controls, 3-7  
RA-series disk drives, 3-1  
Removable media  
function, 1-26  
Removing a tape cartridge, 3-22  
Reset button, 1-17  
Restarting the system  
description, 2-11  
Run Mode  
setting of Power-Up Mode switch,  
1-16

## S

---

Serial controllers  
with modem control support,  
1-27  
without modem control support,  
1-27  
SET BOOT *device name* command  
use of, 2-7  
Shutdown procedure  
when turning off system, 2-10  
Switch settings, 2-1  
normal operation, 2-1  
special operation, 2-2  
System circuit breaker  
location, 1-24

System components  
optional, 1-26

## T

---

Tape cartridge  
calibration, 3-21  
handling instructions, 3-19  
inserting, 3-20  
removing, 3-22  
storage guidelines, 3-19  
write-protect switch, 3-17  
TK70 tape cartridge  
labeling, 3-16  
write-protecting, 3-17  
TK70 tape drive  
access to, 3-13  
controls, 3-14  
indicator lights, 3-14  
loading, 3-15  
location, 1-11  
operation, 3-15  
summary of controls, 3-24  
summary of indicator lights,  
3-24  
uses of, 3-13  
TSV05 tape drive  
care of tapes, 3-29  
controls, 3-25  
inserting write-enable ring, 3-33  
loading, 3-27  
restarting, 3-29  
rewinding, 3-28  
unloading, 3-29  
TU81-Plus  
controls, 3-31  
fault correction, 3-37  
tape threading and loading, 3-34  
Turning off the system, 2-10  
Turning on the system, 2-4

## U

---

Unload button, 3-14  
Unloading a tape cartridge, 3-15

Using a new system, 2-1

## **W**

---

Write-protecting  
a tape cartridge, 3-17

Write-protect switch  
on a tape cartridge, 3-17  
Write-protect switches  
for fixed-disk drives, 1-11

Index-4



## HOW TO ORDER ADDITIONAL DOCUMENTATION

<b>From</b>	<b>Call</b>	<b>Write</b>
Alaska, Hawaii, or New Hampshire	603-884-6660	Digital Equipment Corporation P.O. Box CS2008 Nashua, NH 03061
Rest of U.S.A. and Puerto Rico*	1-800-DIGITAL	
* Prepaid orders from Puerto Rico, call DIGITAL's local subsidiary (809-754-7575)		
Canada	800-267-6219 (for software documentation)  613-592-5111 (for hardware documentation)	Digital Equipment of Canada Ltd. 100 Herzberg Road Kanata, Ontario, Canada K2K 2A6 Attn: Direct Order desk
Internal orders (for software documentation)	—	Software Distribution Center (SDC) Digital Equipment Corporation Westminster, MA 01473
Internal orders (for hardware documentation)	DTN: 234-4323 508-351-4323	Publishing & Circulation Serv. (P&CS) NRO3-1/W3 Digital Equipment Corporation Northboro, MA 01532



# Reader's Comments

MicroVAX 3900  
VAXserver 3900  
Operation  
EK-168AA-OM-001

Your comments and suggestions will help us improve the quality of our future documentation. Please note that this form is for comments on documentation only.

I rate this manual's:	Excellent	Good	Fair	Poor
Accuracy (product works as described)	<input type="checkbox"/>	<input type="checkbox"/>	<input type="checkbox"/>	<input type="checkbox"/>
Completeness (enough information)	<input type="checkbox"/>	<input type="checkbox"/>	<input type="checkbox"/>	<input type="checkbox"/>
Clarity (easy to understand)	<input type="checkbox"/>	<input type="checkbox"/>	<input type="checkbox"/>	<input type="checkbox"/>
Organization (structure of subject matter)	<input type="checkbox"/>	<input type="checkbox"/>	<input type="checkbox"/>	<input type="checkbox"/>
Figures (useful)	<input type="checkbox"/>	<input type="checkbox"/>	<input type="checkbox"/>	<input type="checkbox"/>
Examples (useful)	<input type="checkbox"/>	<input type="checkbox"/>	<input type="checkbox"/>	<input type="checkbox"/>
Index (ability to find topic)	<input type="checkbox"/>	<input type="checkbox"/>	<input type="checkbox"/>	<input type="checkbox"/>
Page layout (easy to find information)	<input type="checkbox"/>	<input type="checkbox"/>	<input type="checkbox"/>	<input type="checkbox"/>

What I like best about this manual: \_\_\_\_\_

What I like least about this manual: \_\_\_\_\_

My additional comments or suggestions for improving this manual:

I found the following errors in this manual:

Page	Description
_____	_____
_____	_____
_____	_____

Please indicate the type of user/reader that you most nearly represent:

- |   |   |
|---|---|
| <input type="checkbox"/> Administrative Support | <input type="checkbox"/> Scientist/Engineer           |
| <input type="checkbox"/> Computer Operator      | <input type="checkbox"/> Software Support             |
| <input type="checkbox"/> Educator/Trainer       | <input type="checkbox"/> System Manager               |
| <input type="checkbox"/> Programmer/Analyst     | <input type="checkbox"/> Other (please specify) _____ |
| <input type="checkbox"/> Sales                  |   |

Name/Title \_\_\_\_\_ Dept. \_\_\_\_\_

Company \_\_\_\_\_ Date \_\_\_\_\_

Mailing Address \_\_\_\_\_

Phone \_\_\_\_\_

Do Not Tear — Fold Here and Tape

**digital**™



NO POSTAGE  
NECESSARY  
IF MAILED  
IN THE  
UNITED STATES

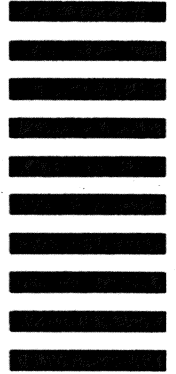

**BUSINESS REPLY MAIL**

FIRST CLASS PERMIT NO.33 MAYNARD MASS.

POSTAGE WILL BE PAID BY ADDRESSEE

**DIGITAL EQUIPMENT CORPORATION  
CORPORATE USER PUBLICATIONS  
MLO5-5/E45  
146 MAIN STREET  
MAYNARD, MA 01754-2571**



Do Not Tear — Fold Here

Cut Along Dotted Li