



**Personal  
Computer**

**Owner's  
Manual**

FEDERAL COMMUNICATIONS COMMISSION (FCC)  
RADIO FREQUENCY INTERFERENCE STATEMENT

## WARNING

This equipment has been certified to comply with the limits for a Class B computing device, pursuant to Subpart J of Part 15 of FCC Rules. Only peripherals (computer input/output devices, terminals, printers, etc.) certified to comply with the Class B limits may be attached to this computer. Operation with non-certified peripherals is likely to result in interference to radio and TV reception.

## Information to User

This equipment generates and uses radio frequency energy and if not installed and used properly, that is, in strict accordance with the manufacturer's instructions, may cause interference to radio and television reception. It has been type tested and found to comply with the limits for a Class B computing device in accordance with the specifications in Subpart J of Part 15 of FCC Rules, which are designed to provide reasonable protection against such interference in a residential installation. However, there is no guarantee that interference will not occur in a particular installation. If this equipment does cause interference to radio or television reception, which can be determined by turning the equipment off and on, the user is encouraged to try to correct the interference by one or more of the following measures:

- Reorient the receiving antenna
- Relocate the computer with respect to the receiver
- Move the computer away from the receiver
- Plug the computer into a different outlet so that computer and receiver are on different branch circuits.

If necessary, the user should consult the dealer or an experienced radio/television technician for additional suggestions. The user may find the following booklet prepared by the Federal Communications Commission helpful: "How to Identify and Resolve Radio-TV Interference Problems". This booklet is available from the U.S. Government Printing Office, Washington, DC 20402, Stock No. 004-000-00345-4.

The NCR Corporation (NCR) is not responsible for any radio or television interference caused by unauthorized modifications of this equipment or the substitution or attachment of connecting cables and equipment other than those specified by NCR. The correction of interferences caused by such unauthorized modification, substitution or attachment will be the responsibility of the user.

MS and GW (MS™-DOS, MS™-MACRO Assembler, GW™-BASIC) are trademarks of Microsoft Corporation. TUTOR and PAL are products of Comprehensive Software Support, Inc.

### First Edition, April, 1985

It is the policy of NCR Corporation to improve products as new technology, components, software, and firmware become available. NCR Corporation, therefore, reserves the right to change specifications without prior notice.

All features, functions, and operations described herein may not be marketed by NCR in all parts of the world. In some instances, photographs are of equipment prototypes. Therefore, before using this document, consult your NCR representative or NCR office for information that is applicable and current.



## CUSTOMER PROGRAM LICENSE AGREEMENT

**YOU SHOULD CAREFULLY READ THE FOLLOWING TERMS AND CONDITIONS BEFORE OPENING THIS PACKAGE. OPENING THIS PACKAGE INDICATES YOUR ACCEPTANCE OF THESE TERMS AND CONDITIONS. IF YOU DO NOT AGREE WITH THEM, YOU SHOULD PROMPTLY RETURN THE PACKAGE UNOPENED AND YOUR MONEY WILL BE REFUNDED.**

This License Agreement applies to the Program contained in the accompanying package. Unauthorized copying is prohibited by the Copyright Law. YOU MAY NOT USE, COPY, MODIFY OR TRANSFER THE PROGRAM, IN WHOLE OR IN PART, EXCEPT AS EXPRESSLY PROVIDED FOR IN THIS LICENSE AGREEMENT. The Program is or may be considered by the copyright owner or licensor of NCR as confidential, proprietary and a trade secret and should be safeguarded by you as such. Title to the Program and copies of it remains with the copyright owner.

### LICENSE

You may:

- a. use the Program only on a single machine at a single location, unless the Program has been specifically designated by NCR, in writing or on this package, for your use on a group of machines.
- b. copy the Program into any machine readable or printed form for backup or modification purposes only, to support your use of it on the single machine or designated group of machines. (Certain programs may include mechanisms to limit or inhibit copying. They may be designated by a "Copy Protected" notice);
- c. modify the Program for your use on the single machine or designated group of machines. (Any portion of the Program merged into another program will be considered to be a modification and will be subject to the terms and conditions of this License Agreement); and
- d. transfer the Program and license to another party only if the other party agrees to accept the terms and conditions of this License Agreement. You must advise NCR of the name and address of the other party and the other party must accept the terms of this License Agreement by signing a copy of it and providing NCR with the signed copy. If you transfer the Program, you must at the same time destroy all copies whether in printed or machine-readable form which you have not transferred to the other party and this includes all modifications of the Program (including portions of it contained or merged into other programs).

You must reproduce and include any copyright notice and serial number on any copy, modification or portion merged into another program.

**IF YOU TRANSFER POSSESSION OF ANY COPY, MODIFICATION OR MERGED PROGRAM TO ANOTHER PARTY, YOUR LICENSE WILL BE AUTOMATICALLY TERMINATED.**

### TERM

Your license will be effective until terminated. You may terminate it at any time by destroying the Program, including all copies, modifications and merged portions in any form. It will also terminate upon conditions set forth elsewhere in this License Agreement or if you fail to comply with any term or condition in this License Agreement. You agree that upon any such termination you will destroy the Program, including all copies, modifications and merged portions in any form.

## EXCLUSION OF WARRANTY

EXCEPT AS STATED IN THE "LIMITED WARRANTY" BELOW, THE PROGRAM IS PROVIDED "AS IS" WITHOUT WARRANTY OF ANY KIND, EITHER EXPRESSED OR IMPLIED, INCLUDING BUT NOT LIMITED TO THE IMPLIED WARRANTIES OF MERCHANTABILITY AND FITNESS FOR A PARTICULAR PURPOSE. THE ENTIRE RISK AS TO THE QUALITY AND PERFORMANCE OF THE PROGRAM IS WITH YOU. SHOULD THE PROGRAM PROVE DEFECTIVE, YOU (AND NOT NCR OR ITS DEALER OR DISTRIBUTOR OR ANY LICENSOR OF NCR OR OWNER OF THE PROGRAM) ASSUME THE ENTIRE COST OF ALL NECESSARY SERVICING, REPAIR OR CORRECTION. There is no warranty by NCR or any other party or person that the functions contained in the Program will meet your requirements or that the operation of the Program will be uninterrupted or error free. You assume all responsibility for the selection of the Program to achieve your intended results, and for the installation, use and results obtained from it.

## LIMITED WARRANTY

NCR warrants both the media on which the Program is reproduced and the reproduction of the Program on the media to be free from defects in materials and workmanship under normal use for a period of ninety (90) days from the date of delivery to you as evidenced by a copy of your receipt.

NCR's entire liability and your exclusive remedy shall be:

1. The repair or replacement of any media not meeting NCR's "Limited Warranty" and which is returned to NCR or an authorized NCR dealer or distributor within the 90-day period, with a copy of your receipt, or
2. If NCR or its authorized dealer or distributor is unable to deliver replacement media and repair is not practicable or cannot be timely made, you may terminate this License Agreement by returning the Program and your money will be refunded.

IN NO EVENT WILL NCR OR ANY OTHER PARTY OR PERSON BE LIABLE TO YOU OR ANYONE ELSE FOR ANY DAMAGES, INCLUDING LOST PROFITS, LOST SAVINGS OR OTHER INCIDENTAL OR CONSEQUENTIAL DAMAGES ARISING OUT OF THE USE OR INABILITY TO USE THE PROGRAM OR MEDIA EVEN IF NCR OR THE OTHER PARTY OR PERSON HAS BEEN ADVISED OF THE POSSIBILITY OF SUCH DAMAGES.

Some states do not allow limitations on how long an implied warranty lasts, so the above exclusion may not apply to you.

Some states do not allow limitations or exclusion of liability for incidental or consequential damages so the above limitation or exclusion may not apply to you.

This warranty gives you specific legal rights and you may also have other rights which vary from state to state.

## MISCELLANEOUS

You may not sublicense, assign or transfer the license or the Program except as expressly provided in this License Agreement. Any attempt otherwise to sublicense, assign or transfer any of the rights, duties or obligations hereunder is prohibited, and will automatically terminate your license and right to use the Program.

This License Agreement will be governed by the laws of the State of Ohio where NCR Corporation has its principal office.

YOU ACKNOWLEDGE THAT YOU HAVE READ THIS AGREEMENT, UNDERSTAND IT AND AGREE TO BE BOUND BY ITS TERMS AND CONDITIONS. YOU FURTHER AGREE THAT IT IS THE COMPLETE AND EXCLUSIVE STATEMENT OF THE AGREEMENT BETWEEN US AND THAT IT SUPERSEDES ANY PROPOSAL OR PRIOR AGREEMENT, ORAL OR WRITTEN, AND ANY OTHER COMMUNICATIONS BETWEEN US OR BETWEEN YOU AND ANY NCR DEALER OR DISTRIBUTOR RELATING TO THE SUBJECT MATTER OF THIS LICENSE AGREEMENT.

Should you have questions concerning this License Agreement or should you desire to obtain information on warranty performance, you may contact NCR by writing to:

NCR CORPORATION  
1150 Anderson Drive  
Liberty, SC 29657  
USA

# OWNER'S MANUAL

## CONTENTS

### Historical Data

|  |      |
|--|------|
| INTRODUCTION . . . . .                           | 1-1  |
| DOCUMENTS. . . . .                               | 1-1  |
| ADVANCED DOCUMENTS . . . . .                     | 1-2  |
| NEXT STEP . . . . .                              | 1-3  |
| INSTALLATION QUALITY REPORT . . . . .            | 1-3  |
| HELP US HELP YOU. . . . .                        | 1-3  |
| A COMPUTER IS . . . . .                          | 1-3  |
| COMPUTER CAPABILITIES . . . . .                  | 1-4  |
| COMPUTER ADVANTAGES . . . . .                    | 1-4  |
| COMPUTER LIMITATIONS . . . . .                   | 1-4  |
| HISTORICAL DATA AND USAGES . . . . .             | 1-5  |
| COMPUTER SYSTEM COMPONENTS . . . . .             | 1-10 |
| HARDWARE . . . . .                               | 1-10 |
| Central Processing Unit (CPU) . . . . .          | 1-10 |
| Memory . . . . .                                 | 1-11 |
| Internal Memory . . . . .                        | 1-11 |
| External Memory . . . . .                        | 1-12 |
| Input Devices . . . . .                          | 1-14 |
| Output Devices . . . . .                         | 1-14 |
| SOFTWARE . . . . .                               | 1-14 |
| System Software . . . . .                        | 1-15 |
| The Operating System . . . . .                   | 1-15 |
| Run-time Interpreter Routines . . . . .          | 1-16 |
| Utility Programs . . . . .                       | 1-16 |
| Program Development Software . . . . .           | 1-16 |
| Editors . . . . .                                | 1-17 |
| Assemblers . . . . .                             | 1-17 |
| Compilers . . . . .                              | 1-18 |
| Linkers . . . . .                                | 1-18 |
| Application Software. . . . .                    | 1-18 |
| READING, WRITING, PRESENTATION OF DATA . . . . . | 1-19 |
| The Binary System . . . . .                      | 1-19 |
| Recording Data in Internal Memory . . . . .      | 1-21 |
| Recording Data in External Memory . . . . .      | 1-21 |
| Fixed Disks . . . . .                            | 1-21 |
| Flexible Disks . . . . .                         | 1-22 |

RELATIONSHIP BETWEEN HARDWARE,  
SOFTWARE, AND DATA . . . . . 1-25

**Ready — Set — Go**

READY . . . . . 2-1  
 SITE SELECTION AND PREPARATION . . . . . 2-1  
 UNPACKING . . . . . 2-2  
 CONNECTIONS . . . . . 2-3  
 COMPUTER COMPONENTS CHECKLIST . . . . . 2-5  
     Cabinet. . . . . 2-7  
     Keyboard . . . . . 2-7  
     Software . . . . . 2-8

SET . . . . . 2-9  
 POWER-ON PROCEDURE . . . . . 2-9

GO . . . . . 2-11  
 TURN IT ON . . . . . 2-11  
 APPLICATION SOFTWARE . . . . . 2-11  
 KEYBOARD FEATURES . . . . . 2-11  
     Rollover . . . . . 2-11  
     Auto-repeat . . . . . 2-11  
     Keys. . . . . 2-12  
     Groups . . . . . 2-12  
     Control Keys. . . . . 2-13  
     Typewriter Keys . . . . . 2-15  
     Cursor Keys . . . . . 2-16  
     Numeric Keys . . . . . 2-17  
 AN OUNCE OF PREVENTION . . . . . 2-18  
     Human Error . . . . . 2-18  
     Daily Care . . . . . 2-19

**OPTIONS INSTALLATION**

PREPARATIONS . . . . . 3-1  
 CABINET DISASSEMBLY . . . . . 3-1  
     Card Rack Assembly Removal . . . . . 3-2  
 CABINET REASSEMBLY . . . . . 3-3  
     Card Rack Reassembly . . . . . 3-3  
 MAIN PROCESSOR BOARD (MPB) . . . . . 3-4  
 BOARD INSTALLATION . . . . . 3-5  
 BOARD REMOVAL . . . . . 3-8  
     Monochrome Monitor Adapter Board (Freestanding  
     Display) . . . . . 3-9

|   |             |
|---|-------------|
| Color Display/Graphics Display Board (Freestanding Display) . . . . . | 3-11        |
| Alpha Controller Board (Internal Display). . . . .                    | 3-12        |
| 32K/64K Graphics Controller Boards (Internal Display) . . . . .       | 3-13        |
| 32K Graphics Controller Board Memory Expansion . . . . .              | 3-16        |
| Expanded Memory . . . . .   | 3-17        |
| To Install Chips: . . . . .   | 3-18        |
| Main Processor Board Memory . . . . .                                 | 3-19        |
| Memory Expansion Board . . . . .                                      | 3-20        |
| Numeric Coprocessor. . . . .  | 3-22        |
| <b>SERIAL AND PARALLEL PORTS . . . . .</b>                            | <b>3-23</b> |
| Serial Port . . . . .   | 3-24        |
| Parallel Port. . . . .  | 3-25        |
| <b>EXTERNAL VIDEO DISPLAYS . . . . .</b>                              | <b>3-26</b> |
| Display Switch Settings . . . . .                                     | 3-26        |
| <b>EXTERNAL DISPLAY INSTALLATION . . . . .</b>                        | <b>3-26</b> |
| <b>FLEXIBLE DISK DRIVE . . . . .</b>                                  | <b>3-28</b> |
| <b>FIXED DISK DRIVE . . . . .</b>                                     | <b>3-32</b> |
| <b>DRIVE REMOVAL . . . . .</b>  | <b>3-37</b> |
| <b>COMPUTER TILT AND SWIVEL MECHANISM . . . . .</b>                   | <b>3-39</b> |

## **Maintenance and Troubleshooting**

|  |            |
|--|------------|
| <b>MAINTENANCE . . . . .</b>                 | <b>4-1</b> |
| RELOCATION . . . . .                         | 4-2        |
| Flexible Disk Drive . . . . .                | 4-2        |
| Fixed Disk Drive . . . . .                   | 4-3        |
| Position the Fixed Head . . . . .            | 4-3        |
| System . . . . .                             | 4-5        |
| Set-Up . . . . .                             | 4-5        |
| Radio/TV Interference . . . . .              | 4-6        |
| <b>TROUBLESHOOTING . . . . .</b>             | <b>4-7</b> |
| <b>USER DIAGNOSTICS. . . . .</b>             | <b>4-7</b> |
| Copy Diagnostics . . . . .                   | 4-7        |
| Error Messages. . . . .                      | 4-8        |
| A Typical Diagnostics Run-Through . . . . .  | 4-9        |
| Memory Test. . . . .                         | 4-10       |
| Controllers Test (Circuit Devices) . . . . . | 4-11       |
| Keyboard Test . . . . .                      | 4-13       |
| Flexible Disk Drive Test . . . . .           | 4-14       |
| Fixed Disk Drive Test . . . . .              | 4-15       |
| Monochrome Display Test . . . . .            | 4-16       |

Color/Graphics Display Test . . . . . 4-17  
Peripherals Test . . . . . 4-21  
Tape Drive Test . . . . . 4-22  
Continuous Run of Tests from Main Menu . . . . . 4-23  
Utilities Menu . . . . . 4-23  
Add/Delete Test Modules . . . . . 4-25  
Run All Tests . . . . . 4-28  
Exit from Diagnostics . . . . . 4-28

**Appendix A Keyboard Functions . . . . . A-1**  
**Appendix B Technical Data . . . . . B-1**  
**Appendix C System Switch Settings . . . . . C-1**  
**Glossary . . . . . G-1**  
**Index . . . . . I-1**



## Historical Data

### INTRODUCTION

Welcome to the world of computing on your NCR PERSONAL COMPUTER, and the worldwide family of satisfied NCR customers.

You've been introduced to your computer with the NCR PAL program and, just for fun, you've probably played a few games of BLACKJACK. Now, you're ready to gain in-depth knowledge of your new computer.

### DOCUMENTS

Helping you gain confidence and ability in the use of your computer are the manuals for the system. These manuals are:

- Owner's Manual — the one you're now reading. You get a User Diagnostics diskette with this manual. A whole chapter in this manual tells you about diagnostics.
- NCR-DOS Manual — This is a detailed reference to the features and use of the NCR-DOS operating system software that is standard for this computer. You get three diskettes with this manual, NCR-DOS/GW-BASIC on two diskettes, and NCR TUTOR. TUTOR helps you to master NCR-DOS commands and concepts.
- GW-BASIC Manual — GW-BASIC is the standard program development software for your NCR Personal Computer. Program development software simply means that when you're ready to write or modify programs yourself, this manual is your reference to the features, instructions and programming

techniques available in this GW-BASIC language. The GW-BASIC diskette is provided in the NCR-DOS manual.

Diskettes in these manuals contain the software you're going to hear so much about. In simplistic terms, software is like the old fashioned telephone operator — it's the middle man — you talk via the keyboard to the software — the software via firmware communicates with the hardware — and then comes back to you with some response. Without software you cannot communicate with your computer. There are several types of software:

1. System Software, e.g., NCR-DOS
2. Program Development Software e.g., GW-BASIC
3. Diagnostics Software, e.g., User Diagnostics
4. Self-teaching Software, e.g., NCR PAL and NCR TUTOR
5. Application Software, e.g., specific use programs.

## **ADVANCED DOCUMENTS**

There are three additional manuals available for the owner who wants to become more deeply involved with the programming or servicing of the computer. They are:

### **NCR-DOS Programmer's Manual**

This is a very technical software reference book containing detailed information on several topics, i.e., MS-MACRO assembler language, utilities, and several others.

### **Technical Reference Manual**

This is a very technical hardware reference manual with detailed illustrations and descriptions of standard and optional hardware components.

### **Hardware Maintenance and Service Manual**

This book describes in detail the procedures for both preventive and corrective maintenance for your NCR Personal Computer and each hardware component.

These manuals are available through your authorized NCR dealer or your NCR representative by ordering NCR stock:

1. *NCR DOS Programmer's Manual* — G6B1-0204-0000

2. *Technical Reference Manual* — 150-0000967

3. *Hardware Maintenance and Service Manual* — 150-0000968

## **NEXT STEP**

If you are already familiar with computers and their operation, you may want to go to Chapter 2 and check off your computer components and set-up, then to Chapter 3 for instructions on optional equipment installation. Read the first four chapters of the NCR-DOS manual and practice with the NCR TUTOR before you go on to other applications.

Novices and experienced users may find the historical data about computers of interest. Some of the terms may be unfamiliar to you. If so, check the Glossary for definitions. More information about the history of the development of computing or computer concepts is available from your public or company libraries, college or university libraries, your dealer or NCR representative, or a bookstore.

Numerous magazines are published for personal computer owners and users. Joining a computer club or visiting local computer shows could also broaden your exposure to computing.

## **INSTALLATION QUALITY REPORT**

Don't forget to fill out your Installation Quality Report Card that is included in your *Getting Started* booklet. Mail the card in to NCR right away. This information will help us serve you better in the future.

## **HELP US HELP YOU**

NCR wants you to be satisfied with the use of your NCR Personal Computer. A major factor in your learning process on the computer is the ease of use of our documentation. NCR spends a great deal of time and money in the preparation of these publications and we would like to know that it has been worth it. After you have spent some time with the equipment and the documentation, fill out and send in the postage-paid Reader's Comments Card bound into the back of this manual. Thank you.

## **A COMPUTER IS**

A computer is a machine that performs tasks by processing information as directed by logically-organized sets of instructions called software or programs. Computers come in various sizes, shapes, and types. One can be so big that its parts are located

throughout an entire building, and another can be so small that the entire system fits within a wristwatch.

## **COMPUTER CAPABILITIES**

A computer can perform only a few basic arithmetic and data handling operations. It can add, subtract, compare one quantity to another, and move or modify data. In most computers, even multiplication and division are performed through repetitive addition and subtraction. It executes operations in sequence, but can be told to “jump” or “branch” out of sequence to another instruction in the program, either unconditionally (every time) or conditionally. For example, you could branch if two variables were equal, or not branch if the same two variables were unequal. Each time your computer performs a task, i.e., reading or writing words and sentences, it must perform one or more of the basic operations.

## **COMPUTER ADVANTAGES**

The computer’s power lies in the fact that it is: fast, accurate, and has storage and recall. Fast — it can perform thousands of arithmetic operations and comparisons in the time it took you to read this sentence. Accurate — your computer gives exactly the same answer to the same calculation or comparison, as long as the same program is used, regardless of how often it occurs. Storage and recall — it stores programs, files, and tables of information that can be read back into the computer to update, compare, or for whatever purpose you require.

## **COMPUTER LIMITATIONS**

A computer has tremendous capabilities and probably appears to have a very fast, efficient mind, but it does not have the qualities of a human mind such as intuition, deductive reasoning (not yet, anyway), or subjective judgment. The computer’s decisions can be objective only — Is that color RED or BLUE? YES or NO? — Never subjective — Which color is prettier?

The computer must be told what to do at all times by using programs. Within its capabilities, the limitations of what your computer can do for you are imposed by physical makeup — hardware, i.e., amount of storage, speed of processing, existence of optional features such as a printer — by the degree of cleverness, thoroughness and precision with which the programs are designed and written, and by your imagination.

## **HISTORICAL DATA AND USAGES**

Mathematicians and other scientists attempted, for centuries, to conceive machines which would speed up, or in some cases make possible, the solution of complex formulas and equations.

### **The Punched Card**

Herman Hollerith of the United States government Bureau of the Census devised the first punched card and card processing equipment as a means of capturing, sequencing, summarizing and reporting census data around the turn of the Twentieth Century.

### **Mechanized Accounting**

Beginning about the 1920's and continuing into the 1950's two forms of mechanical processing of business information (mostly accounting data) became common — punched card and carriage-style accounting machines.

Punched card accounting machines of several types — sorters, collators, reproducers, tabulating machines, etc., used replaceable plugboards. Each unique task required a specially wired board.

Carriage-style accounting machines were developed with typewriter-style keyboards plus function and numeric keys. Many of these machines used specially-built replaceable “program bars” or “form bars” for each task. A “program bar” was a steel bar approximately the width of the carriage, to which an assortment of differently shaped metal “lugs” or “stops” were attached. Each stop contacted appropriate sensors on the body of the machine. Different shapes told the machine when to move and stop the carriage, wait for keyboard input, add the value entered to a machine total, print a value or a total, etc.

### **Electronic Age**

Electronic technology emerged and advanced in the years leading up to World War II as mathematicians and engineers at leading universities and elsewhere researched ways to use electronic technology to accomplish the goal of a computing machine.

Some mechanical components, such as totals storage devices, were gradually replaced by electronic components in punched card and carriage style accounting machines. The methods in which the machines functioned remained essentially the same.

## **Stored Program Concept**

One of the most critical developments in the modernization of the equipment was the emergence of the idea of a stored program computer. Replaceable programs (sets of instructions) accomplish the definition and control of the machine's current task in a stored program computer, in contrast to the punched card accounting machine with its replaceable boards or the carriage-style accounting machine with its program bars.

## **Digital Computers**

The digital computer was the concept which made stored programs practical. All values, inputs, outputs, and the program itself, are represented as digits or numbers in these computers. Stored program digital computers became more common and eventually dominant as electronic technology matured.

## **Maxi, Mini, Micro**

Since stored programs became practical, many manufacturers, both existing companies and totally new ones, have entered the computer business. Millions of digital computers of various sizes have been built.

The trend towards larger processors was dominant for several years. Univac's LARC (Livermore Atomic Research Computer) and IBM's STRETCH are examples of the extremely large and powerful machines whose capabilities far exceed the dreams of the ancient mathematicians. Meanwhile, over the years, electronic technology advanced at an accelerated rate, dramatically decreasing the size, cost, and electrical power requirements for computer hardware.

The production of minicomputers (mini's) increased in the 1960's. Processors about the size of suitcases, but more powerful than some earlier room-sized computers, enabled mini's to take over tasks previously assigned to large computer "Mainframes". Most frequently mini's were used where the use of a computer had previously been impractical due to both size and cost.

The 1970's saw electronics components decreasing in size so that first dozens, then hundreds, then thousands, and today hundreds of thousands of components can be integrated onto a tiny silicon wafer, or chip. The microprocessor, the "computer on a chip", was produced in volume.

Microprocessors (micro's) are used in places where computers could not be considered previously. Micros perform under the hoods of

millions of cars, in the controls of many recent TV sets, ranges and ovens, in electronic video and arcade games, and in virtually every bank teller machine, point-of-sale terminal, or freestanding cash register built within the last several years.

### **Small Computers**

Every home and small business "personal size" computer, such as your NCR Personal Computer, contains at least one microprocessor as its "heart". Some personal computers have more than one microprocessor, each performing specific tasks.

### **Computer Uses**

Computers are used for thousands of different tasks in business, government, education, and homes. They manage information quickly and efficiently. Thus, in any situation where information is to be managed, use of a computer may be appropriate. Most businesses and many households can benefit greatly from the use of computers. As you become familiar with your computer, you will discover many new and exciting jobs it can do for you.

### **Business**

Some of the multiple purposes for computers in the business world are:

1. Performing accounting functions — payroll, payables, receivables, general ledger, taxes, cost accounting, and spreadsheet presentations.
2. Maintaining inventories and processing orders for manufacturers, distributors, and retailers.
3. Building and maintaining files of customers, vendors, manufacturers, clients, employees and others with whom the business deals, and producing reports from this data base.
4. Processing sales, purchases, billings, and other transactions of the business; maintaining transaction history; projecting future transaction volume and type.
5. Controlling reservations for airlines, hotels/motels, and rental cars. A worldwide network interconnects all major airlines to allow exchange of information on ticketing, lost luggage, weather, etc.

6. Word processing, office automation, electronic mail.

## **Government**

Governments at all levels — city, county, state, and national-use computers. Many of the pioneering computer installations and some of the world's largest computer installations are in the U.S. Federal Government. Some examples of their uses are:

1. Social Security Administration, Internal Revenue Service, and state and local tax agencies' processing, checking, recordkeeping, and check-writing.
2. Controls and monitors space flights, from the early Vanguard days to and beyond the Space Shuttle.
3. Weather forecasting.
4. Connecting network between the FBI and most other federal, state, and local law enforcement agencies for wanteds, outstanding warrants, fingerprint identification, and other criminal justice purposes.
5. Military command and control networks, air defense, missile control and guidance, weapons system development, project planning and control systems, worldwide communications.

## **Education**

Primary schools through post-graduate schools use computers in teaching and research as well as in recordkeeping. These uses include:

1. Student recordkeeping and printing of grade reports.
2. Teaching of computer literacy, programming and other data processing and related subjects.
3. Planning and control of research projects and processing of results.
4. Computer-assisted learning.
5. Research in artificial intelligence, robotics, computer-aided diagnosis, etc.
6. Maintaining records of alumni and fund donors.



## Homes

Common uses of the computer in the home are:

1. Education for the whole family, adults as well as children:
  - a. in computer programming
  - b. in other subjects, such as math, for which programmed-instruction diskettes or cartridges were developed
2. Keeping track of personal finances and other household book-keeping.
3. Tax preparation.
4. Building, maintaining and using files of addresses, telephone numbers and birthdates.
5. Word processing for preparation of letters, term papers, and essays without retyping for changes and corrections.
6. Entertainment with games.

Attachments of one or more components lets the home computer act to:

1. Monitor home security, and turn lights/radios on/off at predetermined times.
2. Control heating, air-conditioning and other appliances.

The addition of a communications adapter and a modem allows the home computer to talk (exchange data) with other small computers or with larger computers over telephone lines.

One of the common hookups available is one of the national or regional information source services. Through such a service the home computer user can:

1. Send and receive electronic mail. You can leave messages for and get messages from other users of the service (friends, strangers, children away at college).
2. Obtain stock market quotations, and worldwide news and sports event results.

3. Exchange information with other users.

Another arrangement that is becoming more popular is for a person, whose professional duties can be performed from a computer terminal, e.g., a computer programmer, or a technical writer, to actually work from a home computer which is dialed-up as a terminal from the employer's central computer.

Bank-from-home and shop-from-home services can also be used by a home computer user who installs the necessary communications adapter and modem and makes arrangements where these services are available.

## COMPUTER SYSTEM COMPONENTS

A computer system has two component categories, hardware and software.

### HARDWARE

Hardware encompasses all of the physical parts of a computer system. Each component performs a particular function and plays a specific role in processing data:

1. Central Processing Unit — Arithmetic Logic Unit.
2. Memory (internal).
3. Memory (external) — disk drives and disks, tape drives and tapes.
4. Input devices — keyboards, etc.
5. Output devices — cathode ray tube (CRT), display screens, printers.
6. Communications adapters, modems.
7. Cables, circuit boards.

### Central Processing Unit (CPU)

The CPU is the "heart" of a computer. Data are processed in the CPU. It contains all the arithmetic and logical circuitry in the computer, and often has a component called the Arithmetic and Logic Unit (ALU). All other circuitry in the computer is essentially for data transfer — to/from the CPU, internal memory, external memory — under the control of the CPU.

The execution of the program instructions currently in the computer is also performed in the CPU. The machine-language instructions are loaded into an instruction register and decoded into either specially-wired circuits or unique microcoding to accomplish the steps of that specific instruction.

The CPU contains:

1. Control circuitry, including a next instruction address register.
2. Greater, less than, and equal indicators to reflect the result of the latest comparison instruction executed.
3. Arithmetic overflow and zero result indicators.
4. In many cases, one or more sets of "address registers" (storage areas each large enough to store a memory address, such as the base address for a block of coding, a block of data, or a table of information; a return point for a branch out-of-line; or an interrupt routine address).

Data to be processed arithmetically or logically are normally retrieved from internal memory into the CPU under control of the CPU. Data resulting from CPU operations are stored back into internal memory.

## **Memory**

The term memory encompasses the various hardware devices used by the computer to "remember" or store data and instruction sets it requires to process data. Two types of memory are used: internal and external.

### **Internal Memory**

Internal memory is the storage area within the computer to which CPU has direct access. The "memory size" of the computer is normally stated as the number of bytes of internal memory, such as 128KB, 640KB, where K (Greek kilo, or thousand) represents 2 to the 10th power or 1024 bytes.

Two primary types of internal memory are random access memory (RAM), sometimes called "User memory" in smaller personal computers, and read only memory (ROM).

RAM is used as temporary memory. Only the programs and data with which the computer is currently working are in memory at any instant. The operating system programs and the applications

programs are read from external storage into internal memory at the start of the day or the start of the specific run under CPU control.

Data files are read from external memory into internal memory as needed. In fact, unless a data file is relatively small, only the portion of the file currently being accessed is read into internal memory. Portions of files are read either sequentially or randomly, depending on the characteristics of the external memory hardware and the design of the application program.

Also, data are input into internal memory from an input keyboard or other device if required by the program.

When processing of the data in internal memory is complete, then data modified, added, or created are written out to external memory. Information to be printed or displayed to the operator on the CRT is also transferred from internal memory, under CPU control.

When the current program is finished, the next set of application programs and data to be processed replaces the information in the internal memory.

Information in RAM memory is recorded electronically, but is "volatile". That is, its content is maintained by a constant small electric current; the information is lost if the current is interrupted.

ROM memory, by contrast, is permanent; the information stored is not affected if the power to the computer is turned off. Information stored in ROM when it is manufactured cannot be changed.

One almost universal use of ROM memory is to contain a routine to set up ("boot") the machine for processing whenever the power is turned on. This routine normally loads the operating system software from external memory and then passes control to the operating system.

Another use of ROM in some small business and personal computers is to contain BASIC language interpreter routines.

## **External Memory**

External memory includes all forms of data storage other than internal memory. Most external memory devices magnetically record information on and read information from some form of magnetic disks or tapes. Other types of external memory (used much less in recent years) are nonmagnetic, such as punched cards or punched paper tape.

External memory devices which record and read magnetically are of two primary types:

## 1. Disk Drives

- a. Fixed disk drives use either a single disk, or a stack of disks (a disk “pack”). Each disk is a rigid circle of plastic or aluminum with a metal oxide coating on one or both sides.

Removable disks are disks, or disk packs, that can be physically removed from the drive.

Fixed disks are disks that are permanently installed in the drive.

- b. Flexible disk drives use a single soft circle of plastic material with a metal oxide coating on one or both sides. The flexible disk (diskette) is always removable.

The industry standard sizes of diskettes are 8-inch and 5-1/4-inch.

Either size diskette can be single- or double-density (bits per inch [bpi] of recorded information), single or double-sided, and soft-sectored or hard-sectored.

## 2. Magnetic Tape Drives

- a. Devices normally referred to as magnetic tape drives use reels of industry standard tapes with a metal oxide coating on one side.
- b. Cassette tape drives use industry standard digital cassettes.
- c. Cartridge tape drives use industry standard tape cartridges.

General characteristics of external memory are:

1. It is an extension of main memory because information recorded in external memory is written there initially from internal memory under CPU control and read back into internal memory for processing.
2. It is permanent, that means that the information is not erased from memory when the power is turned off.
3. With the exception of fixed disks, it uses removable, replaceable, interchangeable storage elements (disks, diskettes, magnetic tapes). Thus any number of storage elements can be created or stored, and can be kept for as long as needed.

4. You can modify it. New data or current data in modified form can be recorded over previously recorded data when the storage element is attached to, or inserted into, the external memory device.

### **Input Devices**

Programs and data are read into the computer's internal memory, under CPU control, through input devices for use in processing.

Most external memory devices are used for input of data previously recorded by your computer or another computer or data capture device. Examples of devices through which entry of data or program instructions can be made are a keyboard, a light pen, or a mouse.

Many computers can receive input via communications lines from original entry terminals, programmable terminals, i.e., terminals that process the data before sending it, and other computers.

### **Output Devices**

Data and programs are transferred from internal memory, under CPU control, to output devices during or after the system has finished processing. Much of a computer's output is to external memory (disks, diskettes, magnetic tapes) for future recall.

The display is an output device, one that displays instructions or questions to the operator, and final output from many functions.

A hardcopy of the final results from many processing functions is printed, if a printer is present.

Many computers can send, or return, output over communication lines to terminals or other computers.

### **SOFTWARE**

The term software has come into general use to categorize the portions of any computer system that does not include the hardware. It consists of programs (sets of instructions) used to:

1. Process data
2. Create other programs
3. Control the computer's operation

The software program types are determined by the purpose for which the program is used. The three main types are:

1. System — operating systems, run-time interpreters and utilities.
2. Program development — editors, compilers, assemblers, and linkers.
3. Application — payroll, billing, games, word processing, etc.

Programs are written in a language called a source language. The file created by entering source language instructions into the computer is referred to as source code. Depending on the source language used, the source code may be translated by a compiler or assembler which then produces the object code. The object code is usually machine-language code (the language understood by the CPU). On some computers, the object code is directly executable. Othertimes, the object code requires further processing by a linker into an executable load module which the CPU and the operating system can use.

### **System Software**

System software are standard programs whose presence is essential for your computer to operate. They consist of:

1. Operating system program — control programs that permit and initiate the running of all other kinds of programs, such as application programs.
2. Run-time interpreter routines.
3. Utility programs.

Some manufacturers supply not only a primary operating system with the hardware, but any necessary run-time interpreters, and a comprehensive set of utility programs. You may want to obtain multiple operating systems. A great variety of software is available to you from either the manufacturer (or dealer) or retail software development companies.

### **The Operating System**

The operating system provides an orderly link between the hardware and software of a computer system. It is a program, or a collection of programs, that control all other programs in the computer, allocate the computer's resources (memory, disk space, printer, etc.) and prepare the computer to accept the commands or instructions of other programs.

The operating system provides communication abilities between you and your computer through prompts and commands. A prompt is a displayed message or other signal by the operating system that indicates you should make a decision or perform some action before the system can continue. Sometimes you are given a specific set of choices, such as Y/N (Yes/No). Other times the system completes a portion or all of a task and you enter one of the set of commands recognized by your operating system. These commands direct the system to perform tasks like:

1. Begin the next program desired.
  2. Rename or delete a file.
  3. Display the directory (list of contents) of a disk.
- An example of an operating system is the NCR-DOS.

### **Run-time Interpreter Routines**

A computer that executes directly from a source code needs a run-time interpreter. The run-time interpreter has routines which perform specific sets of machine-language operations to accomplish the purpose of each instruction. The GW-BASIC interpreter is an example of a run-time interpreter.

### **Utility Programs**

Every computer needs utility programs to perform very common functions, such as text editing of data or program source code, copying, comparing, or sorting data files, formatting of disks or diskettes, etc. Utility programs can be called in by operating system commands, or they can be accessed like application programs.

### **Program Development Software**

A specific set of source code instructions, data description techniques and conventions, and procedures used to create programs make up a programming language. Included also are control instructions to direct the program development software or run-time interpreter to translate the source code into object code which is (after any necessary linking and conversion) machine-understandable.

The final code tells the computer what operations to perform and in what sequence.

This type of software consists of programs that make it possible for other programs to be written or modified, translated into machine language, or stored until they are used.



The primary program development software for use on your personal computer is often supplied by the computer manufacturer. Additional software can be obtained from the manufacturer or a software development company.

To write any new programs or make changes in any accounting program, game, or other programs you have on hand, you need the program development software. To use across-the-counter application software, you do not need to learn the use of this software. You may, however, have to run LINK on some purchased software to make it readable by your computer.

### **Editors**

An editor program lets you create or modify source code for one language, store the code, and test and run the program directly. To test and run the program you need a run-time interpreter for the language. GW-BASIC contains such an editor.

### **Assemblers**

An assembler program translates source code from the computer assembly language to an object code. Such a program is a low-level program language, so called because each program, in general, generates one machine-language instruction. For example, the instruction ADD tells the assembler to generate the machine instruction for addition.

Macro-instructions, "Macros", are the exceptions to one-for-one translation. A typical Macro is a single statement to get the next data record from a file of records. The assembler includes, from its Macro library, the standard set of machine instructions necessary to:

1. Locate the record.
2. Read a data block from external memory, if necessary.
3. Test for read errors.
4. Set a register or other pointer to the beginning address of the record in internal memory.

MS-MACRO Assembler, available through your NCR Personal Computer dealer, is an example of this type of software.

## **Compilers**

A compiler program translates source code from a program language into object code. These languages are called "high-level" languages because each program statement generates several machine-language instructions. These languages may be designed to be either more like common English (i.e., BASIC and COBOL), or to use normal mathematical/scientific notation (i.e., FORTRAN and ALGOL). The languages can also be procedure-oriented, i.e., Pascal and PL/1. Your NCR Personal Computer dealer has compilers available for GW-BASIC, COBOL, FORTRAN, and Pascal.

## **Linkers**

Linker programs process one or more object code modules which have been output from a compiler or assembler into one load module, to create a program the computer can run.

## **Application Software**

Application software programs are the tools you use to perform specific functions such as:

1. Accounting, inventory, and order management.
2. Word processing, office automation, electronic mail.
3. Personal finances and correspondence.
4. Entertainment and education at home.
5. Processing sales, purchases, billings, and other transactions.
6. Processing tax and Social Security data.
7. Controlling and monitoring space flights and military operations.
8. Student record keeping, teaching programming, and research.
9. Communicating with information source services and, through them, with other computer users.
10. Bank-at-home, shop-at-home, and even work-at-home arrangements.

System software and program development software do not accomplish data processing. However, they are used in creating and

utilizing application software. Application software does the actual processing of business, government, school, and personal data. Different application programs are required to perform different application requirements. If you first want to process data for your household budget, and then you want to correct a draft of a letter or term paper, you switch from the personal finance software to your word processing program.

You can acquire application software from a variety of sources. Some computer manufacturers contract with independent software development companies for distribution rights to some application programs. Other manufacturers develop and sell application programs. You can buy many programs directly from independent software development companies.

NCR offers a wide variety of applications for your NCR Personal Computer. Any application software marketed by NCR or by independent companies specifically for the NCR Personal Computer may be used. Some application software originally developed for use on other PC's may also be used.

## **READING, WRITING, PRESENTATION OF DATA**

### **The Binary System**

Electronic circuits and magnetic storage devices are capable of carrying, storing, or recognizing only two "states", either voltage is present (high) or absent (low); magnetizable (ferrite) particles are either lined up in the same direction (polarized) for a high, or unpolarized for a low state.

The high state is considered to have the value "1"; the low state "0". Every character of information is represented by a pattern of ones and zeroes. This form of representation is the binary system.

Each individual element in the pattern is called a "bit" (binary digit). In most computers, the smallest addressable element is a group of eight bits, known as a byte. Within eight bits, the number of possible combinations is 2 to the power 8 or 256.

It is convenient to think of each bit location in magnetic storage or electrical circuitry as if it were a switch (see Figures 1-1, 1-2, and 1-3).

Most computers represent data in accordance with the American Standard Code for Information Interchange, ASCII (pronounced "As key") Code. In ASCII 128 possible unique characters are defined, from 0000 0000 (NUL) through 0111 1111 (DEL) (see Figure 1-4). Another

code used in many computers is EBCDIC which uses B sub8 as a data bit and thus has 256 possible unique characters.

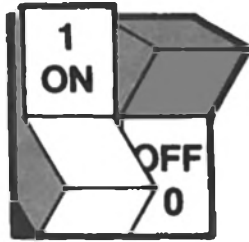

Figure 1-1 Switch Representation — Binary 1 and 0

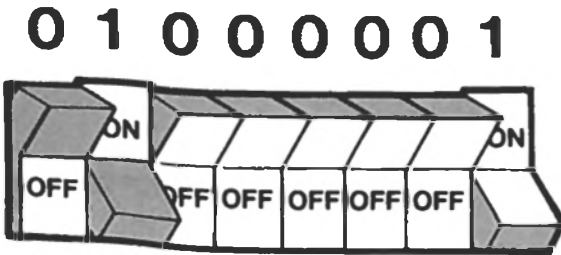

Figure 1-2 Switch Representation — Binary A



Figure 1-3 Binary Representation — D

| NCR ASCII CODE CHART  |      |      |      |      |      |      |      |      |      |      |      |      |      |      |      |      |     |
|-----------------------|------|------|------|------|------|------|------|------|------|------|------|------|------|------|------|------|-----|
| $B_4 \rightarrow B_1$ | 0000 | 0001 | 0010 | 0011 | 0100 | 0101 | 0110 | 0111 | 1000 | 1001 | 1010 | 1011 | 1100 | 1101 | 1110 | 1111 |     |
| $B_8 \rightarrow B_5$ | 0    | 1    | 2    | 3    | 4    | 5    | 6    | 7    | 8    | 9    | A    | B    | C    | D    | E    | F    |     |
| 0000                  | 0    | NUL  | SOH  | STX  | ETX  | EOT  | ENO  | ACK  | BEL  | BS   | HT   | LF   | VT   | FF   | CR   | SO   | SI  |
| 0001                  | 1    | DLE  | DC1  | DC2  | DC3  | DC4  | NAK  | SYN  | ETB  | CAN  | EM   | SUB  | ESC  | FS   | GS   | RS   | US  |
| 0010                  | 2    | ␣    | '    | "    | #    | \$   | %    | &    | '    |      | ~    | .    | ,    | -    | _    | /    |     |
| 0011                  | 3    | 0    | 1    | 2    | 3    | 4    | 5    | 6    | 7    | 8    | 9    |      |      | <    | =    | >    | ?   |
| 0100                  | 4    | @    | A    | B    | C    | D    | E    | F    | G    | H    | I    | J    | K    | L    | M    | N    | O   |
| 0101                  | 5    | P    | Q    | R    | S    | T    | U    | V    | W    | X    | Y    | Z    | [    | \    | ]    | ^    | _   |
| 0110                  | 6    | `    | a    | b    | c    | d    | e    | f    | g    | h    | i    | j    | k    | l    | m    | n    | o   |
| 0111                  | 7    | p    | q    | r    | s    | t    | u    | v    | w    | x    | y    | z    | {    |      | }    | ~    | DEL |

Figure 1-4 ASCII Code Chart

## Recording Data in Internal Memory

The ability of hardware designers to package more and more memory into smaller and smaller spaces has been a major factor in the reduction in size from the days when Univac I, as the state-of-the-art, required a bedroom-sized memory and processor enclosure to hold a memory of 10,000 12-bit words.

In the Univac I, bits were stored as electrical pulses recirculated through tanks of liquid mercury. Soon that and other early storage techniques were superseded by the use of magnetic core memories. Each ferrite core, shaped like a tiny donut, represented one bit of information. From 16K to 64K bytes of data could be stored in a core array about the size of a suitcase. Core memories, in turn, have been followed by metal oxide semiconductor (MOS) memories. Integrated circuits using MOS technology make possible the storage of 64K or more bits on a single, small chip.

Your NCR Personal Computer, an example of today's state-of-the-art, can have up to 640K 8-bit bytes within its relatively small cabinet along with the disk drives, main processor, other circuit boards, and the power supply.

## Recording Data in External Memory

### Fixed Disks

The fixed disk available on the NCR Personal Computer can store over 20,000,000 bytes (20 megabytes, or 20 MB). Since the maximum capacity of each diskette used in your flexible disk drive(s) is 368,640 bytes (360 KB), you can see that with one fixed disk drive you have the

capacity of over 54 diskettes, greatly expanding your external memory capacity. If you need the larger capacity, the fixed disk is very valuable to you.

### **Flexible Disks**

The flexible disk is contained in a square protective jacket. The diskette spins within the jacket when it is mounted in the disk drive and the drive mechanism is on. Replace the diskette in the heavy protective paper envelope in which it came when you are not using it.

There are two industry-standard diskette sizes: 8-inch, and 5-1/4-inch diameter. Your NCR Personal Computer uses the 5-1/4-inch diskette. Let's examine the characteristics of that diskette:

1. Your computer can record data on one side of the single-sided diskette or on both sides of a double-sided diskette.
2. Diskettes look alike in their protective jackets. The magnetic recording surface of the diskette shows through three openings on each side of the jacket:
  - a. the center opening, where the mechanism that spins the diskette makes contact,
  - b. the small circular hole near the center opening, used for reading an indexing or positioning signal from the diskette,
  - c. the larger oval opening through which data are written to and read from the diskette.

**NOTE:** Do not touch the recording surfaces of the diskette. You can damage it and lose all of the data stored on it.

Keep the diskette away from any magnetized object.

Use a felt tip marker to write on the diskette labels.

Ballpoint pens make an indentation, and pencils leave an abrasive dust.

3. A small notch, called a write-protect notch, is on the edge of most diskettes. On a 5-1/4-inch diskette, if the write-protect notch is not covered you can record data on the diskette. If it is covered with opaque tape, you cannot write to disk. Adhesive tabs are supplied with the diskettes. You can protect the data on your diskette by covering the write-protect notch with an adhesive tab. Cellophane and similar tapes are not satisfactory, since they are not opaque. You can remove the tab easily if you decide to write to your diskette at another time.

4. Diskette labels are at the top when the oval opening is at the bottom. A manufacturer-supplied software diskette, such as NCR-DOS and NCR TUTOR, usually has one wide label across the top. Blank diskettes usually have a smaller square or rectangular label at the top left which includes the manufacturer's name and certification. The user label, or temporary label, is then placed at the top right. You can write identifying information on this, e.g., names of files, programs on the diskette, or a legend like "NCR-DOS back-up", plus the date you created the file, the volume number — it's your choice. Whenever the information on the diskette is replaced by new data, you probably want to replace the label.
  
5. Although the metallic oxide coating over the diskette surface is uniform, it is, for purposes of recording and reading data, considered to consist of concentric circles of magnetizable spots. Each circle is called a "track". On the standard 5-1/4-inch diskette, 40 tracks are defined to exist on each side of the diskette. The tracks are numbered 0 through 39 on one side, and, if the diskette is double-sided, 40 through 79 on the other side (see Figure 1-5).

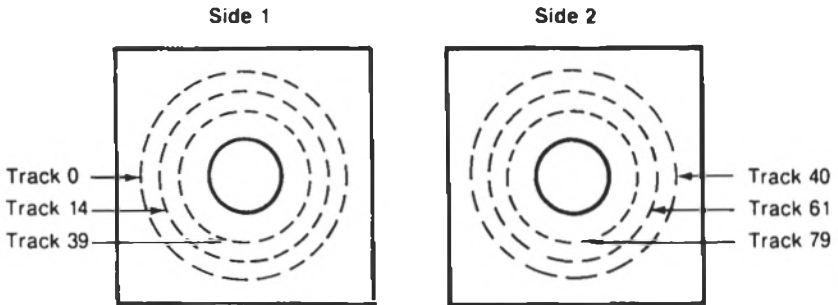

Figure 1-5 Diskette Track Layout

6. Each track is further divided into sectors (see Figure 1-6). Either eight or nine sectors per track can be defined on a diskette. Recording or reading of data by most programs, including application programs, is performed one sector at a time. Thus, the data in each sector can be referred to as a data block, or a physical record (see Figure 1-7). Each data block or physical record can be treated by the software as containing one logical record (the record of one account, one customer, one order, etc.), or as part of one larger logical record, or multiple logical records. A set of

related logical records, such as all customer records, comprises a file.

7. Each sector on the 5-1/4-inch diskette contains 512 bytes. Thus, the maximum storage capacity of a double-sided, double-density diskette is:

512 bytes per sector, times 9 sectors per track, times 40 tracks per side, times 2 sides per disk = 368,640.

A single-sided diskette has a capacity of one-half that, or 184,320 bytes.

8. Each new diskette must be formatted before any data can be stored on it. Formatting consists of recording a track and sector address and a test pattern of bits in every sector of every track of the diskette, reading the test pattern back from every sector to verify write and read accuracy, and creating a file directory so that subsequent programs can create and use files on the diskette.
9. Diskettes are removable and interchangeable. You can create as many as you need and store them for as long as you need. You can reuse each diskette as often as required, either to reread the stored information or to replace it with new information.
10. Each diskette can contain any wanted mix of program and data files up to its storage capacity. This attribute is especially useful if your machine has one disk drive, since you do not need to continually alternate between program diskettes and data diskettes.

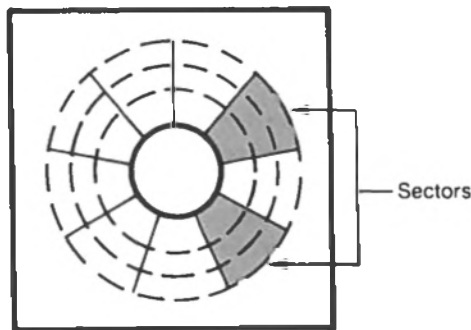

Figure 1-6 Diskette Sectors



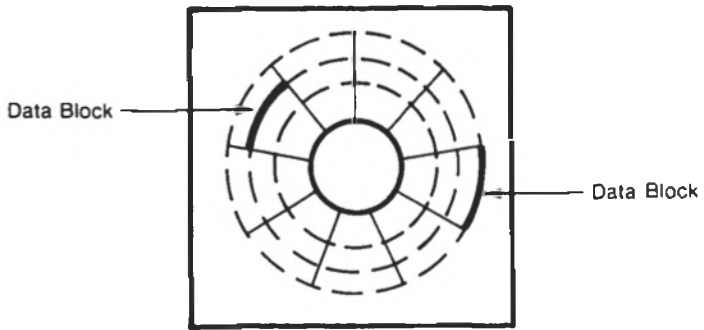

Figure 1-7 Diskette Data Blocks

## RELATIONSHIP BETWEEN HARDWARE, SOFTWARE, AND DATA

A computer can operate only if the hardware and software work together. Normally, the hardware needs to contain an operating system and an application program to perform a task.

Data must be present for productive performance of a task. Data can be a file of customers, inventory, budget information, checks written, or joystick movements directing your spaceship to avoid hazards.

The critical concept is that data does not define part of your computer system. However, the existence of data, and the need to process, rearrange, summarize, store, and report data, justified and caused the existence of the computer.

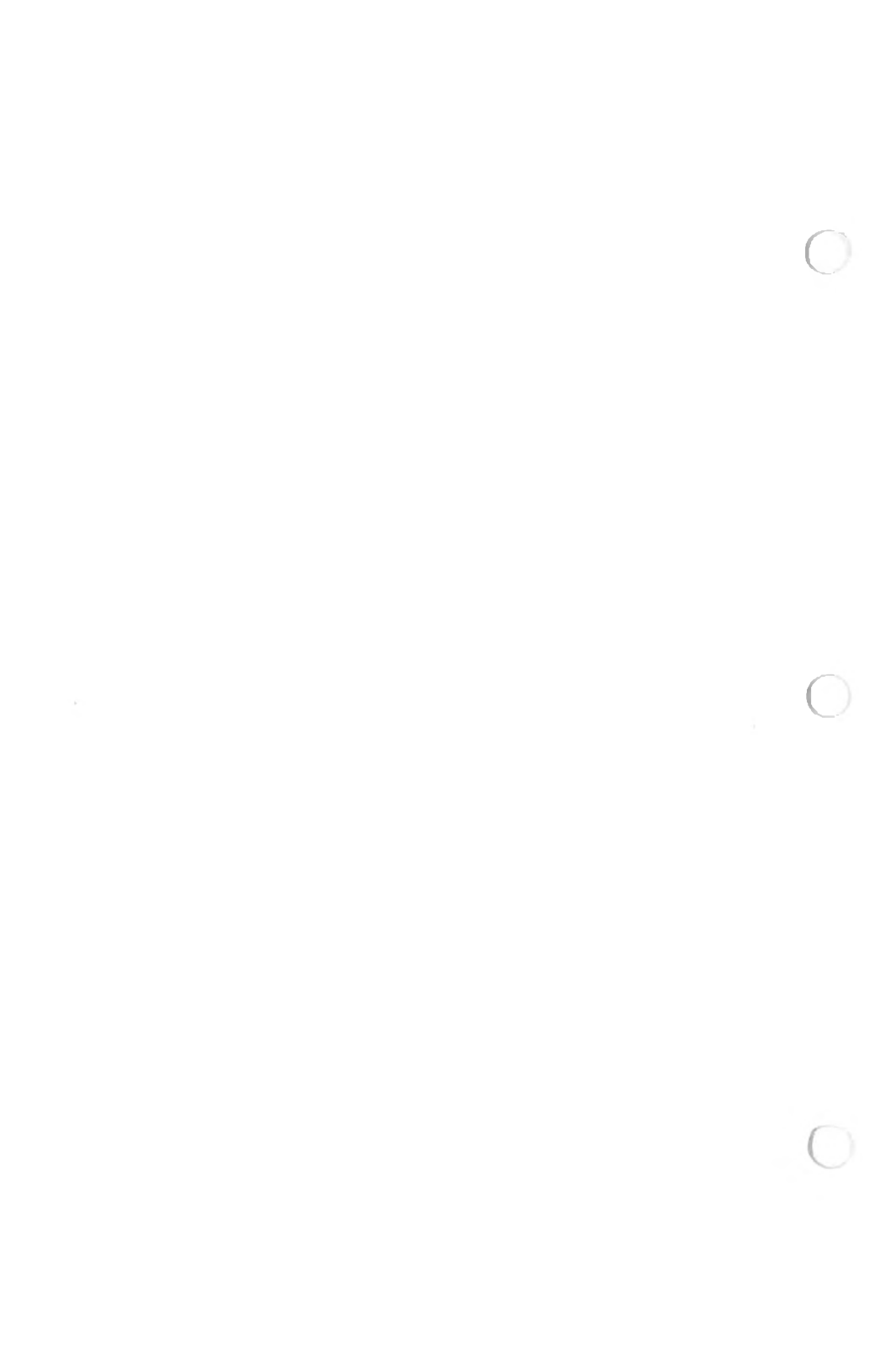

## Ready — Set — Go

### READY

Your NCR Personal Computer is set up. Now you are anxious to get on with it, and to do this you need to know just what equipment you are supposed to have and how it functions. Let's get **READY!**

### SITE SELECTION AND PREPARATION

Be kind to yourself and your computer in selecting a permanent location for your NCR Personal Computer. Select an area conducive to comfort and productivity. Ideally the area should have:

1. No heavy traffic or dust.
2. No extremes in temperature or humidity.
3. No direct sunlight, and away from any heating system.
4. Room for sufficient airflow to cool the unit.
5. An adequate number of properly grounded outlets (3-hole receptacles) for the computer and any associated peripherals.
6. Adequate circuit capacity (circuit breaker or fuse rating less the current required for lights and other devices plugged into the circuit).
7. If possible, no radio or TV receivers on the same circuit.
8. Space to put the power cables and interconnecting cables out of the way of traffic.
9. A work surface strong enough to support the combined weight of the computer, monitor, and peripherals.
10. Sufficient work surface and storage space for work in progress and finished work.

## UNPACKING

If you haven't finished unpacking your computer and the peripherals, do it now.

1. Remove the computer from the box. Save the box and the packing to use in any future moves. Refer to your Getting Started booklet for instructions.
2. If any damage to the computer or peripherals is visible, report it immediately to your dealer or NCR representative.
3. Remove the tabbed inserts in the drives and save these with the boxes (see Figure 2-1).
4. Arrange the components on your workspace in an order comfortable to your use.
5. Make sure the power switch on the front of your computer is in the OFF position before you plug in the power cord (see Figure 2-2).

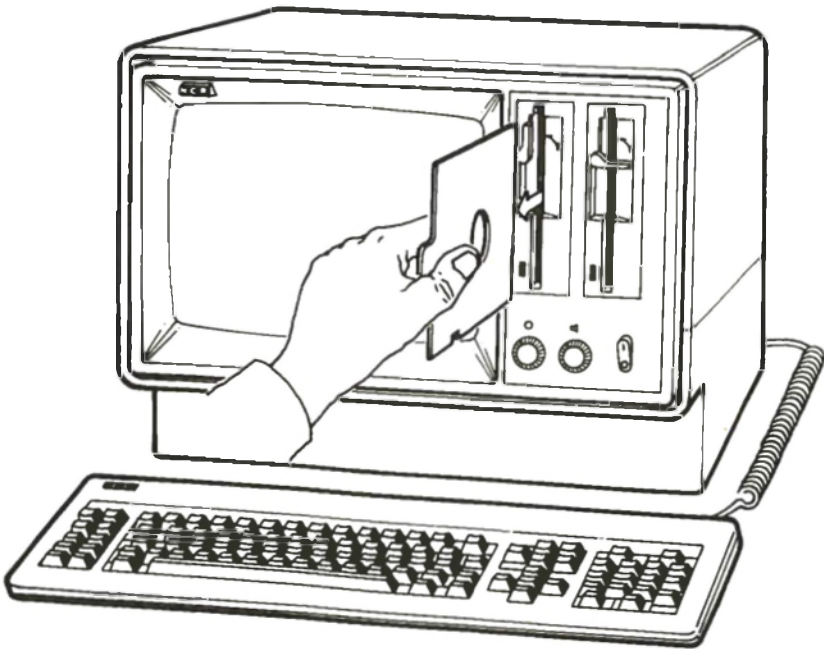

Figure 2-1 Remove Tabbed Inserts From Drives

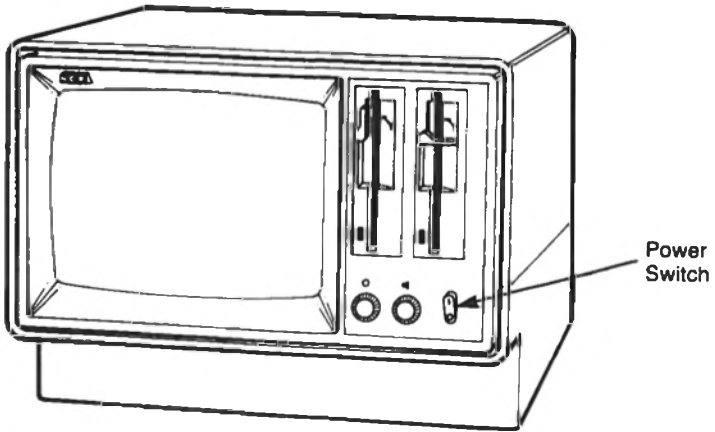

Figure 2-2 Power Switch

## CONNECTIONS

Connect your unit in the following sequence:

1. Plug the keyboard cable into the computer at the rear (see Figure 2-3).
2. Plug the power cord into the computer at the rear (see Figure 2-4).
3. Plug the power cord into a grounded wall outlet.
4. If you have a printer, connect it according to the instruction booklet furnished with it and to the Option Installation chapter in this manual. (NOTE: Many printer types cause vibration on the work surface, so you may want to either set your printer on a separate surface, or on a soft pad to absorb the vibrations.)

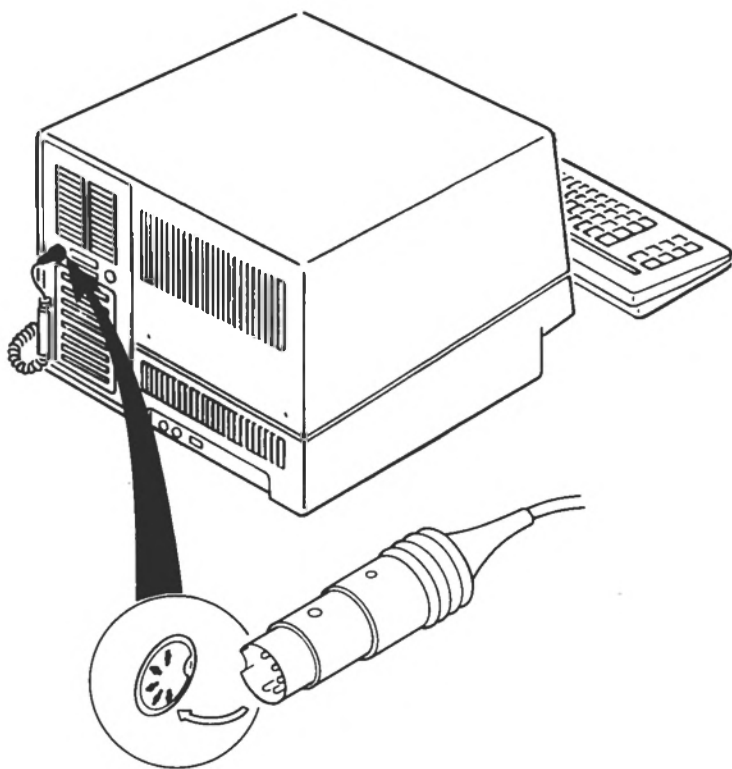

Figure 2-3 Keyboard Cable Connection

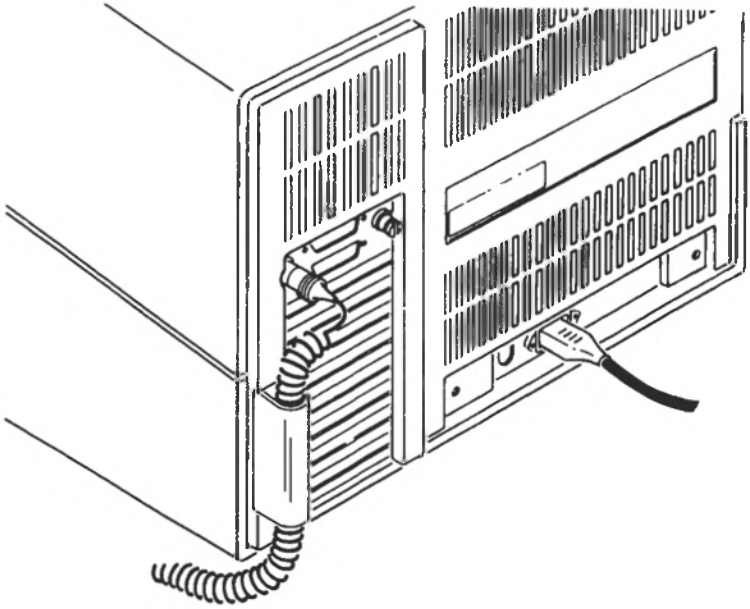

Figure 2-4 Power Cord Connection

### COMPUTER COMPONENTS CHECKLIST

Your NCR PERSONAL COMPUTER PC4i has six different basic models, all of which have 256KB memory capacity. There are available to you several options; these options and how they interface with your computer, are discussed later. Now, you have one of the following basic models:

- |           |  |
|-----------|--|
| 3277-1101 | A 12-inch monochrome display with 1 flexible disk drive and Alpha display controller                       |
| 3277-1102 | A 12-inch monochrome display with 2 flexible disk drives and 32K graphics controller                       |
| 3277-1103 | A 12-inch monochrome display with 1 flexible disk drive and 1 fixed disk drive and 32K graphics controller |
| 3277-1201 | A 12-inch color display with 1 flexible disk drive and 32K graphics controller                             |

3277-1202      A 12-inch color display with 2 flexible disk drives  
and 32K graphics controller

3277-1203      A 12-inch color display with 1 flexible disk drive  
and 1 fixed disk drive and 32K graphics controller

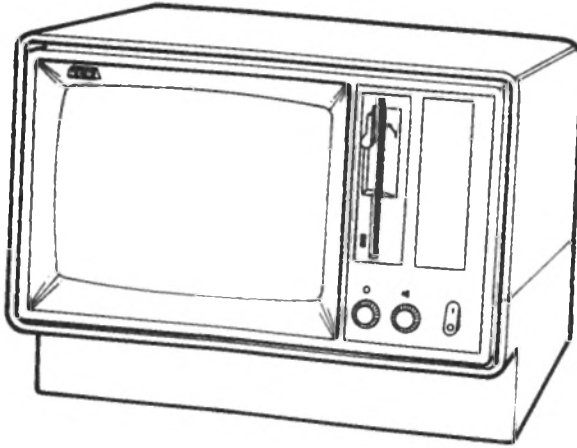

Figure 2-5 One Flexible Disk Drive

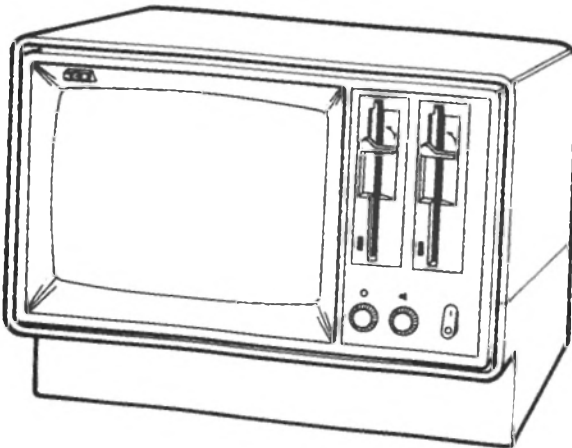

Figure 2-6 Two Flexible Disk Drives



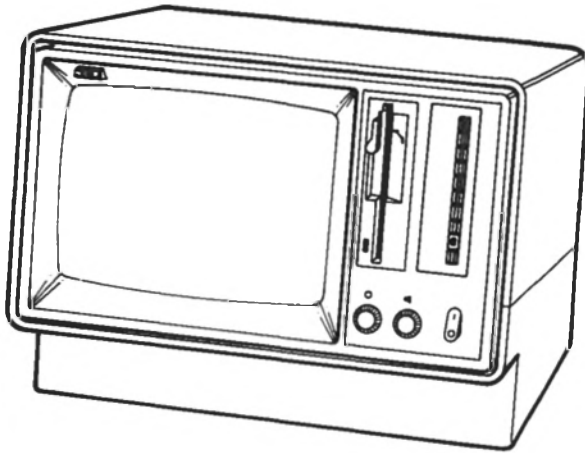

Figure 2-7 One Flexible Disk Drive and One Fixed Disk Drive

### Cabinet

The computer cabinet encloses:

1. A power supply
2. A microprocessor board with:
  - a. 8088-2 microprocessor
  - b. 256 KB random access memory (RAM)
  - c. 16 KB read only memory (ROM)
  - d. RS232C serial interface
  - e. Parallel interface for Centronics type printers
  - f. 8 plug-in board expansion slots
  - g. Controller for up to 2 flexible disk drives
3. Drive slots for 1 flexible disk drive and one optional slot for another flexible disk drive or a fixed disk drive.
4. 12-inch monochrome video display or 12-inch color video display

### Keyboard

The keyboard is a standard feature of this computer and it is described in detail later in this chapter.

## **Software**

Your computer comes with a comprehensive set of system and program development software. A broad selection of application software is available to you in the business and the home computer field. Included are:

1. NCR-DOS
2. GW-BASIC
3. USER DIAGNOSTICS
4. NCR PAL and BLACKJACK
5. NCR TUTOR

## SET

You have everything **READY**, now to get the computer **SET** to operate you should become familiar with the typical computer hums and buzzes.

### POWER-ON PROCEDURE

Each time you turn on your computer the “power-on self-test” is performed by the internal program in the ROM. The sequence is:

1. Turn ON the power switch.
2. The program performs a self-diagnosis of all major components including a memory check.
3. Don't worry! The whirring motor noise from the disk drive is normal.
4. A blinking cursor appears on the screen.
5. The computer beeps to indicate that the system self-test is completed.

If you hear nothing, or if you hear sounds other than those described:

- a. Check the volume control on the speaker and adjust this control, if necessary.
- b. Turn OFF the power switch and turn ON the switch again.
- c. Check that the wall outlet is working properly; plug in a lamp that you are sure works.
- d. If the test is still unsuccessful, call your dealer or NCR representative for advice or to arrange service for the computer. If you purchased a maintenance agreement, follow the instructions you received with that agreement.

If you plan to do the service on your own computer you could refer to the Troubleshooting Nonoperative Systems chapter in the **Hardware Maintenance and Service Manual** (refer to Additional Manuals).

6. If the test is successful and you have optional equipment that you plan to install, turn to the Options Installation chapter in this manual and follow the instructions there and in the installation kit.

**When you have finished with the options installation, return here and continue.**

- 7. Turn ON the power switch; this performs a whole-system power-on test.**
- 8. Adjust the display brightness to your own visual comfort.**
- 9. Sounds may emit from your optional equipment (ignore for now).**
- 10. Go to the troubleshooting section in this manual and perform a diagnostics test on your complete system. Make a note of any error messages and notify your dealer or NCR representative if it is something that you are unable to correct (e.g., you failed to turn the drive lever that locks the diskette in operating position).**

## GO

Finally! Everything is **SET**, and you're anxious to get that equipment doing something.

### TURN IT ON

Your computer must have software to operate. Before you turn on your computer, insert your DOS diskette in the flexible disk drive and turn the drive lever to lock the diskette in operating position. Turn ON the computer, and automatically, the program loads into memory.

### APPLICATION SOFTWARE

There are many application software programs that are compatible with your computer. Your dealer can demonstrate a variety of programs, many of which will meet your software needs.

Each software program has its own instructions for loading and for use. Carefully read these instructions and follow the specific procedure described to load the software into your computer's memory.

Your NCR-DOS manual gives detailed instructions on how to use DOS commands to operate your computer and your GW-BASIC manual tells you how to prepare your own special programs. The diskettes for both GW-BASIC and NCR-DOS are in the back of the NCR-DOS manual.

### KEYBOARD FEATURES

When you begin to experiment with the keyboard, don't be afraid to press different keys just to see what happens. The hardware cannot be damaged by playing with the keys and controls. However, the software can be damaged, so don't experiment when you're using important files. Read the following information carefully.

#### **Rollover**

You can press several keys almost simultaneously and the computer will accept the information in sequence. The keys don't stick or jam, thus you have greater input speed.

#### **Auto-repeat**

Almost every key on your keyboard repeats automatically when you hold it down. The touch of the keyboard is light and you may not realize, at first, that you are depressing a key. Don't worry, just read the key function information and delete the unwanted key strokes.

## Keys

The letters, numbers, and symbols on the keys designate the functions they perform while in the NCR-DOS program. You can program the function of the keys in different programs. The experienced user can do this easily in DOS or in many other software programs.

Some keys have more than one function. With the exception of the Scroll Lock/Break key, the functions of each key are identified by a label on the top of the key (the Break function is on the front of the key). You can determine the different functions of the keys by:

1. Press the key only. This accesses the “unshifted” value of the key, that is:
  - a. the lower function or symbol on the face of the key
  - b. the lowercase representation of the alphabetic letter on the key
  - c. a function designated by the program in use
  
2. Press the key and the **shift** key simultaneously. This accesses the “shifted” value of the key, that is:
  - a. the function or symbol on the face of the key
  - b. the uppercase representation of the alphabetic letter on the key
  - c. a function designated by the program in use
  
3. Press the key and the **Ctrl** key simultaneously. This accesses the “control” value of the key, that is:
  - a. the function labeled on the face of the key
  - b. a function designated by the program in use

## Groups

Keys are grouped according to their functions in DOS. On your left are the program function keys (**F1, F2, F3, F4, F5, F6, F7, F8, F9**,

F10); center stage are the alphanumeric (typewriter) keys and a few control keys; to the right of the alphanumeric keys are the cursor pad keys; and at the far right is the numeric keypad (see Figure 2-8).

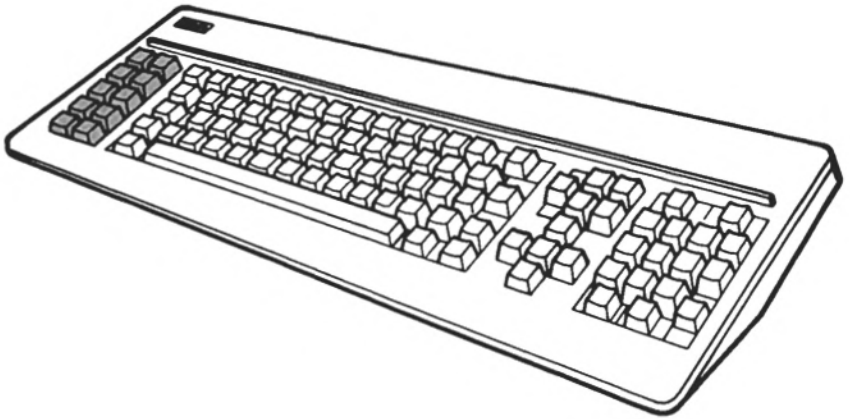

Figure 2-8 Function Keys

### Control Keys

You use the control keys to perform specific acts that are often software dependent. Read the documentation that came with the software program to determine the function of the keys while in that program. You may recognize some of them as being similar to the keys on a typewriter (see Figure 2-9). The following functions are applicable when your computer is running NCR-DOS.

**Enter ( ↵ )** One function of this key is to move the cursor from one line to the next. It works like a typewriter carriage return key. The other function of this key is to enter a program command. In DOS, the **Enter** key terminates entry sequences. There are two **Enter** keys on your keyboard.

**Back Space** This key moves the cursor to the left by one position each time you press it. As it travels backwards the **Back Space** key erases any character it passes over.

B  
 K  
 S  
 P  
 ( ← )

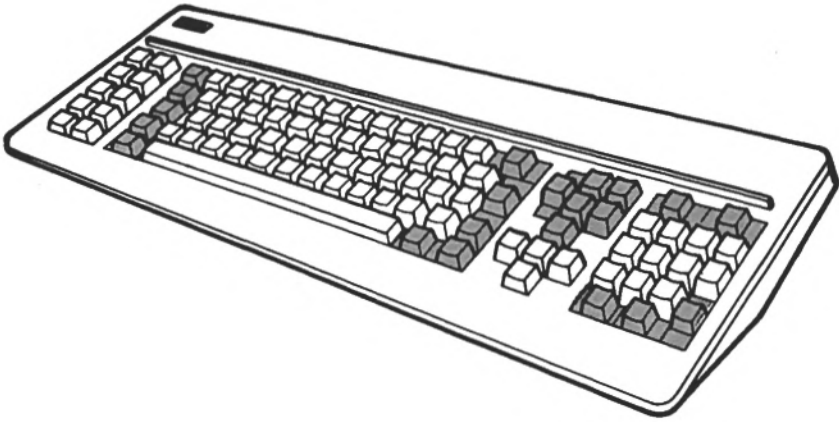

Figure 2-9 Control Keys

- Caps Lock** This key changes the alpha keyboard between the shifted mode and unshifted mode. Press the **Caps Lock** key to activate it and any letter printed will be in uppercase. A small keytip light reminds you that **Caps Lock** is in effect. Press the key again to deactivate it.
- PrtSc\*** The print screen key prints an asterisk when used alone. Used in conjunction with the **Shift** key it causes the printer to print all the data on the screen. The printing process continues until all the screen display is printed. The **Ctrl** key used with the **PrtSc\*** key causes the printer to print what you type until you deactivate it by using the **Ctrl** key with the **PrtSc\*** again.
- Alt** The Alternate key modifies functions of other keys. Hold down the **Alt** key and press the key with the desired function.
- Ctrl** The Control key accesses alternate functions of other keys. Hold the **Ctrl** key down and press the key with the desired alternate function. There are two **Ctrl** keys on your keyboard.
- Esc** The **Escape** key marks the line the cursor is on with a “\”, indicating that this line is to be ignored. The cursor then moves down to the next line.



**Shift** Your keyboard has two **Shift** keys just like a typewriter keyboard. Either key activates the upper-case letters when they are used together. The **Shift** key also accesses the shifted value of keys according to the program in use.

←  
→

The **Tab** key functions similarly to a typewriter tab key. Your DOS program has preset positions on the line so when you press the **Tab** key it moves to these preset positions. Tabs are selectable with software programs.

**Del** The **Delete** key removes characters from text. It does not affect programs, just the data that you enter. There are two **Del** keys on your keyboard. The **Del** key in the numeric keypad has a secondary function as a period.

**Home** The **Home** key returns the cursor to the top left corner of the screen. There are two **Home** keys on your keyboard, one in the Cursor keypad and one in the Numeric keypad.

**Ins** The **Insert** key activates an insert mode in which characters can be entered at the cursor position. Characters that are already on the line are moved to the right to make room for the new characters entered. There are two **Ins** keys on your keyboard.

**Pg Dn** The page down key, inactive in DOS, moves the screen down in predetermined increments. There are two **Pg Dn** keys on your keyboard.

**Pg Up** The page up key, inactive in DOS, moves the screen up in predetermined increments. There are two **Pg Up** keys on your keyboard.

### **Typewriter Keys**

The typewriter keys, identical to a typewriter, are used to write commands or type text (see Figure 2-10). Their function is software dependent.

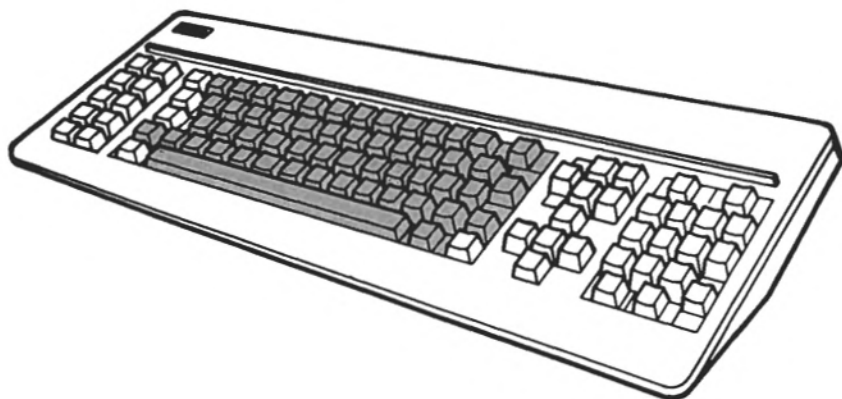

Figure 2-10 Typewriter Keys

## Cursor Keys

- ↑ This upward-arrow key, inactive in DOS, moves the cursor up one line each time you press it. There are two up-arrow keys on your keyboard, one in the Cursor keypad and one in the Numeric keypad (see Figure 2-11). It moves multiple lines if you hold it down. This key is software dependent.
- ↓ This downward-arrow key, inactive in DOS, moves the cursor down one line each time you press it. There are two down-arrow keys on your keyboard, one in the Cursor keypad and one in the Numeric keypad. It moves multiple lines if you hold it down. This key is software dependent.
- The cursor-right key moves the cursor one character to the right each time you depress it. It does not delete any character it passes. There are two right-arrow keys on your keyboard, one in the Cursor keypad and one in the Numeric keypad. It moves multiple spaces if you hold it down.
- ← The cursor-left key moves the cursor one character to the left each time you depress it. It does not delete any character it passes. There are two left-arrow keys on your keyboard, one in the Cursor keypad and one in the Numeric keypad. It moves multiple spaces if you hold it down.

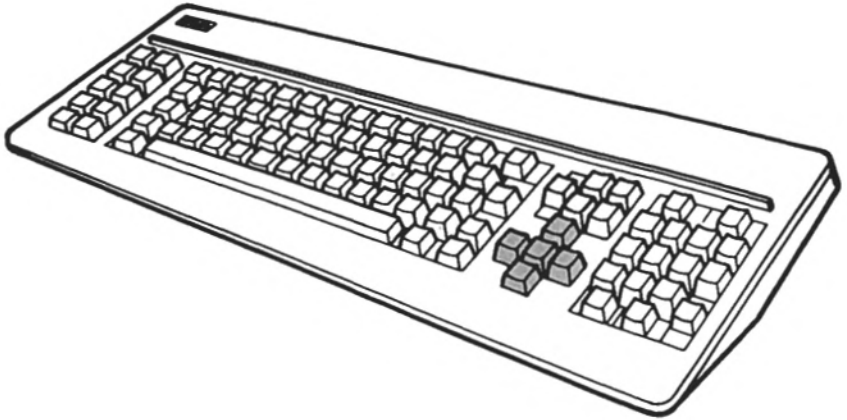

Figure 2-11 Cursor Keys

**End**                    The **End** key, inactive in DOS, moves the cursor to the last character in the current line. You have two **End** keys on your keyboard, one in the Cursor keypad and one in the Numeric keypad. This key is software dependent.

### Numeric Keys

The **Num Lock** key is used to activate and deactivate the number keys on the keypad. When the light on the **Num Lock** is off; the **Pg Up**, **Pg Dn**, **Ins**, **Del**, **Home**, **End** and the **arrow** keys are activated, and they perform the same functions as their counterparts on the cursor keyboard (see Figure 2-12).

Several keys on the Numeric keypad are active at all times: **Num Lock**, **Scroll Lock**, **—**, **+**, **↵ (Enter)**.

### Num Lock

Pressed alone, the **Num Lock** key switches the Numeric keypad between numeric input and cursor movement control mode. When the key light is on, the numeric keys are operational; when the light is off, the cursor movement keys are operational.

If you press the **Num Lock** key with the **Ctrl** key the operation in process is suspended. You can reactivate the process by pressing any key other than **Ctrl**, **Shift**, **Alt**, and **Del**.

**Scroll Lock/Break** When you press this key and hold down the **Ctrl** key the command program stops running.

**0,1,2,3,4,5,6,7,8,9** These keys work interchangeably with the typewriter keypad numeric keys to perform numeric data entry. Use the shift key or the Caps Lock key with the numeric key to type the upper characters on these keys.

**Del .** With the **Num Lock** activated the **Del .** key places a decimal point in your numeric operation.

**—** You use the minus key in numeric functions.

**+** You use the plus key in numeric functions.

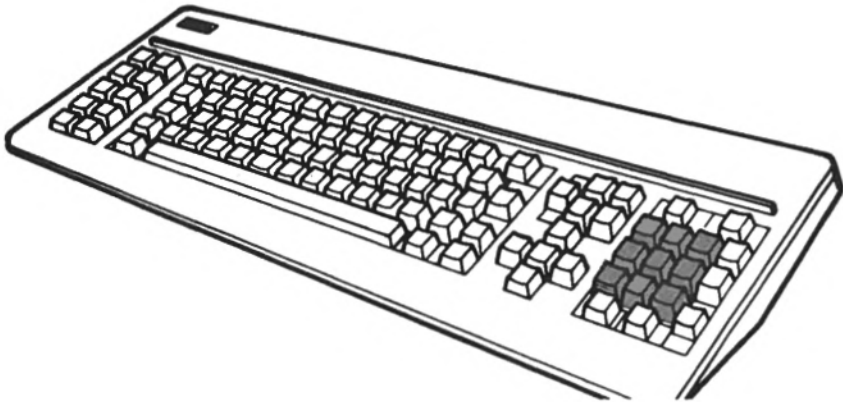

Figure 2-12 Numeric Keys

## AN OUNCE OF PREVENTION

Good operating habits are an ounce of prevention, and in the care and daily operation of your computer, it is certainly worth a pound of cure. So take time to read the Maintenance and Troubleshooting chapter and learn to prevent problems as well as detect them.

## Human Error

Protect yourself from human error:

1. Update your backup copies as you change the originals.
2. If you add or change any information in a data file, then store that information on diskette to prevent loss should the computer lose its power and memory.

### Daily Care

Check to see if any magnetized hardware has been moved into the computer environment. Remember that magnetized objects might damage the diskettes and can affect the computer's memory. Even jewelry can have magnetic properties, so be careful.

Keep your computer environment as static free as possible.

Keep the air circulation vents uncovered (see Figure 2-13).

Remove dust that could get into the computer and affect its performance by cleaning the unit periodically (see Figure 2-14). Clean the display and the cabinets as described in the following:

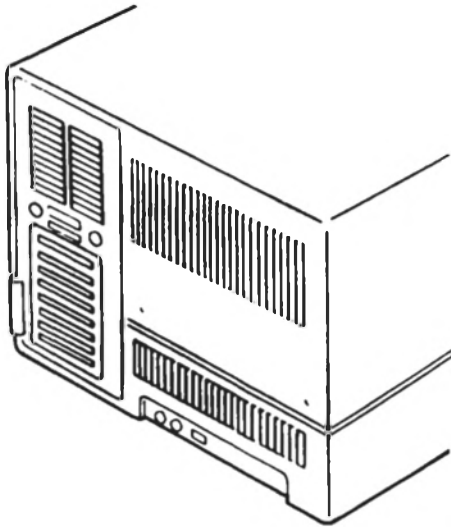

Figure 2-13 Don't Cover Air Vents

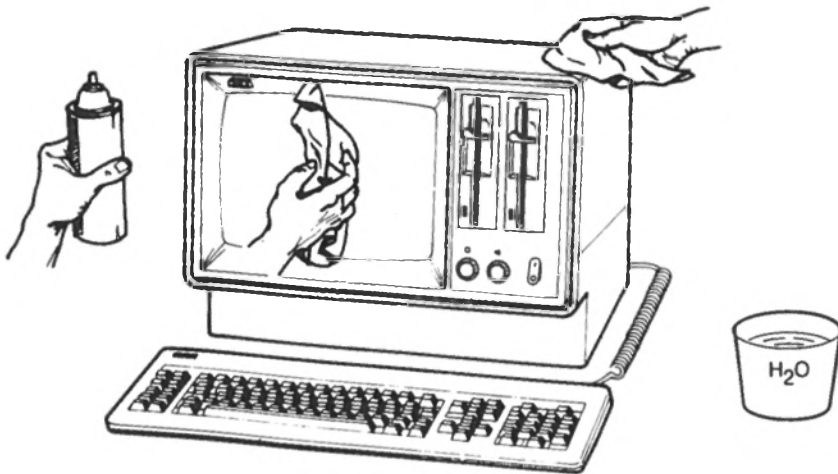

Figure 2-14 Housekeeping

1. Turn OFF the unit.
2. Wipe the screen with a soft cloth and an ammonia-based glass cleaner, a very mild detergent solution, or a water dampened cloth. Dry the screen with a soft cloth.
3. Wipe the cabinet with a cloth slightly dampened by a mild detergent solution, but be careful not to damage the unit by allowing liquid to get inside the cabinet.

## OPTIONS INSTALLATION

NCR offers a variety of computer equipment available in kit form for the NCR PERSONAL COMPUTER PC4i. The procedures here detail only the major ones available. You receive installation instructions with all purchased options and these instructions should be placed in the back of this section for future reference.

### PREPARATIONS

Before starting an installation, assemble the correct tools and parts required to perform the task. Read the instructions specific to your device and heed the WARNING and CAUTIONS given here.

### WARNING

Turn OFF the power switch and unplug the power cord from the wall socket and from the back of the computer before you begin work to avoid electrical shock.

### CAUTIONS

Make sure you have grounded yourself by touching a metal surface before you handle boards or components. A static charge may build up on your person when working with electronic equipment and it could damage these devices.

Use only shielded cables to make printer connections. Nonshielded cables may cause radio and TV reception interference.

### CABINET DISASSEMBLY

1. Turn the screw-lock that secures the card rack assembly 90 degrees counter-clockwise (see Figure 3-2).

2. Grasp the card rack at both sides and carefully pull out two to three inches from the cabinet. (NOTE: The card rack must be pulled away from the cabinet a few inches to allow clearance for the cabinet top.)
3. With a screwdriver, remove the two screws in the lower back of the cabinet (see Figure 3-1).
4. Grasp the cabinet top at both sides, with a slightly outward pull, slide the top off toward the rear.
5. Lay the cabinet top to the side out of the way.

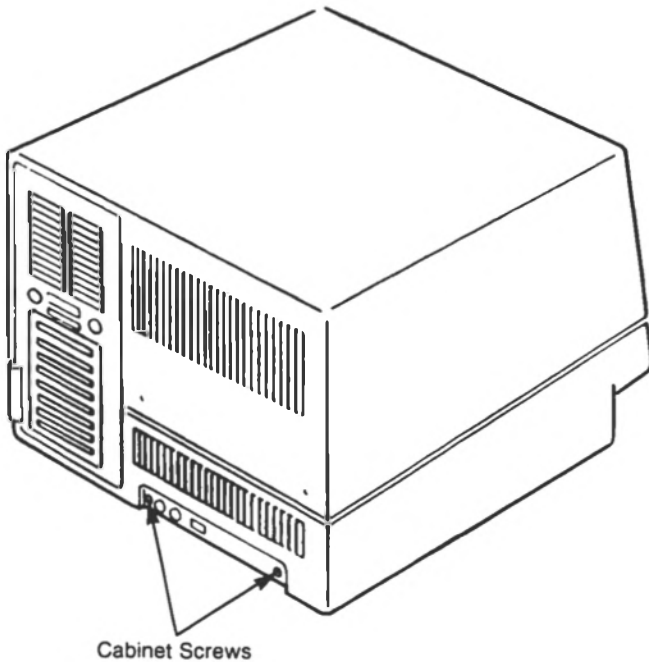

Figure 3-1 Cabinet Removal

### Card Rack Assembly Removal

1. Make a note of their positions, and disconnect any cables that may be connected to the exterior of the card rack assembly. (See Figure 3-8.)
2. Turn the screw-lock that secures the card rack assembly 90 degrees counter-clockwise (see Figure 3-2).



3. Grasp the card rack at both sides and carefully pull out the assembly towards the rear.

The cables connecting the card rack assembly are long enough to allow the assembly to be withdrawn completely from the cabinet.

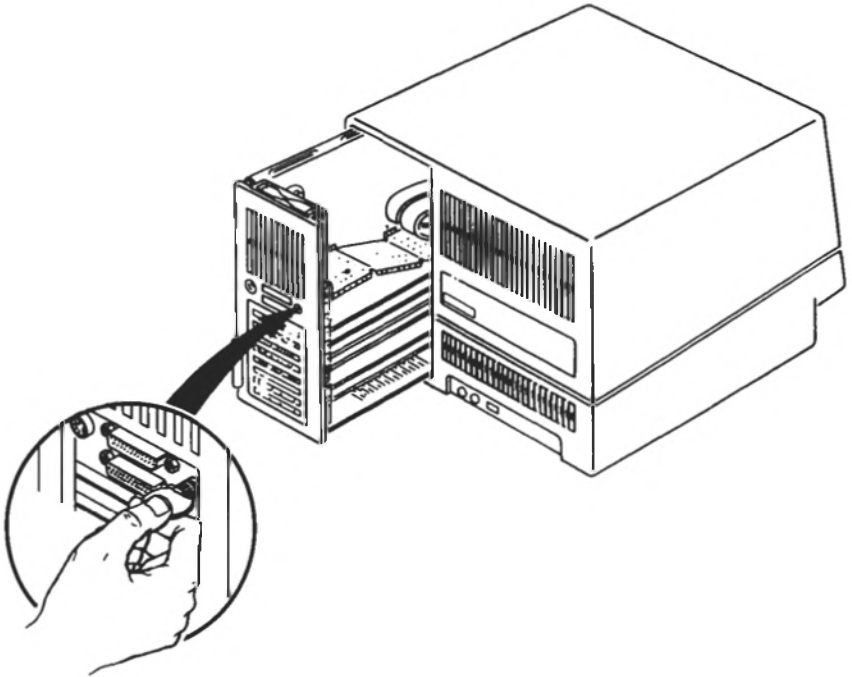

Figure 3-2 Card Rack Assembly Removal

## CABINET REASSEMBLY

1. Place the cabinet top in the grooves of the cabinet bottom and slide the cabinet top over the computer from the back to the front.
2. Replace the two screws into the lower back of the cabinet (refer to Figure 3-1).

## Card Rack Reassembly

1. Carefully slide the card rack assembly into the back of the computer (refer to Figure 3-2). Push firmly into position until the back panel is flush with the cabinet.

NOTE: Make sure the cables connecting the assembly to the computer are not crimped.

2. Turn the screw-lock clockwise to secure the rack into position.
3. Install any peripheral device cables to the appropriate connector at the back of the card rack assembly.

### MAIN PROCESSOR BOARD (MPB)

A layout of the MPB illustrates the location of the switches that may require adjustments when an option is installed (see Figure 3-3). The MPB is mounted vertically in the card rack wall (see Figure 3-4).

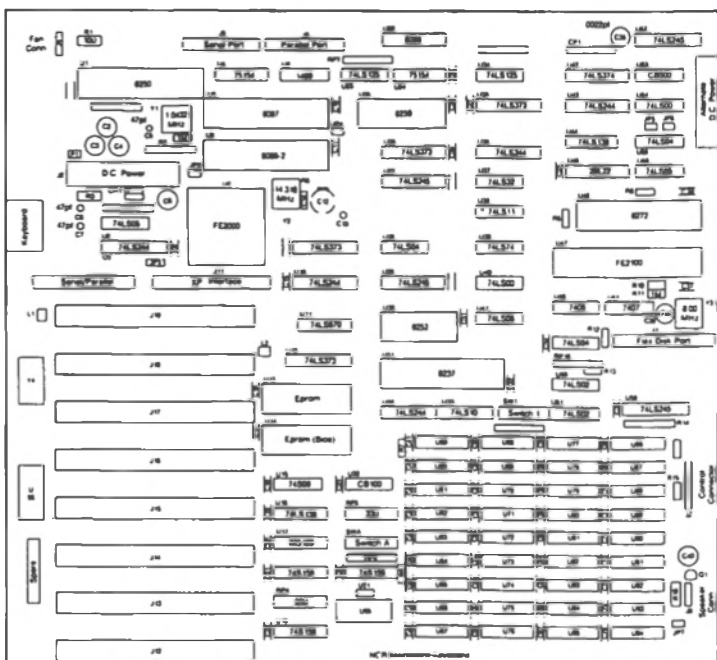

Figure 3-3 Main Processor Board

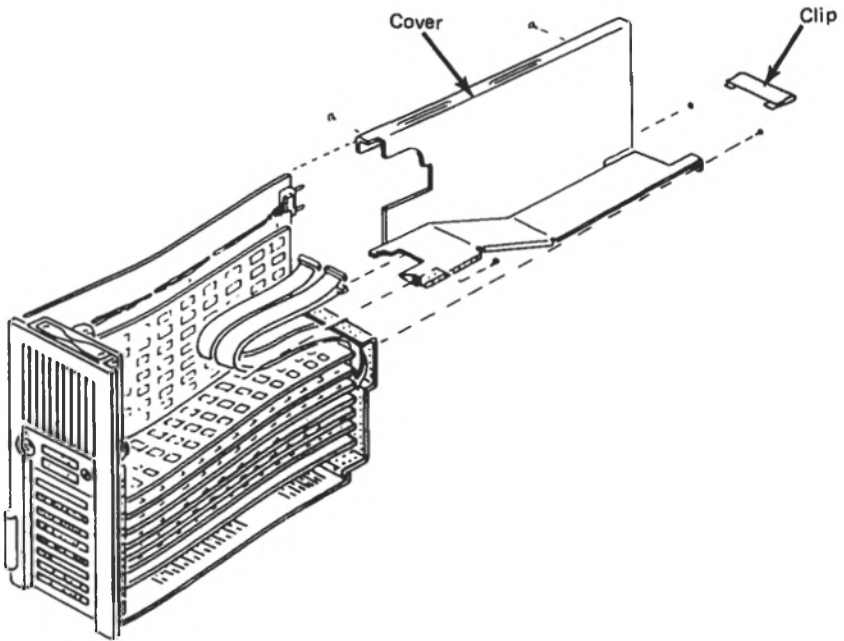

Figure 3-4 MPB Installed

## BOARD INSTALLATION

Carefully read the instructions in the preparation section at the beginning of this chapter and heed the **WARNING** and **CAUTIONS**, then proceed as follows to install a board in your computer:

1. Leave the board in the protective plastic envelope and place it on the working surface beside your computer.
2. Remove the screw from an empty support bracket of the card rack assembly (refer to Figure 3-5).
3. Remove the plastic retaining strip (refer to Figure 3-5).

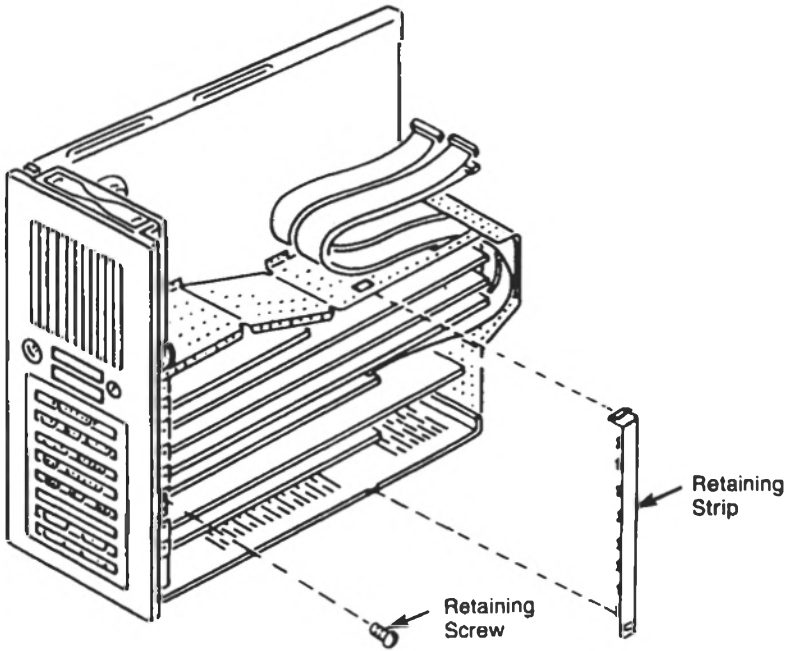

Figure 3-5 Plastic Strip

4. Line up the board with the support bracket and the card guide in the card rack (see Figure 3-6).
5. Push in the board, in a gentle but firm manner, until it is securely plugged into the socket on the MPB.
6. Replace the screw taken out in step 2. Make sure you tighten it securely.

**NOTE:** To install the Numeric Coprocessor, it is necessary to remove the cable clip and cover shown in Figure 3-4. The cover is held in position by five screws.

Installation of a fixed disk drive requires the clip to be removed: the cables leading from the controller to the drive must be held by this clip in the same way that the flexible disk cable is held.

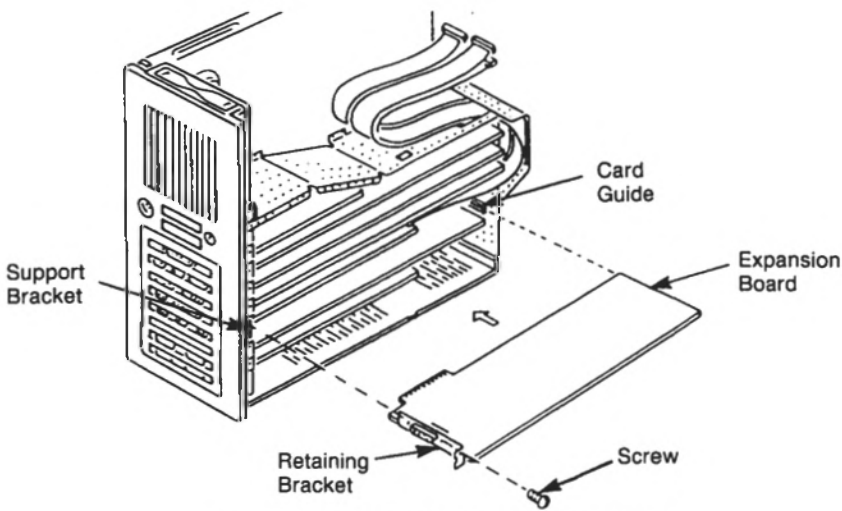

Figure 3-6 Card Guide and Board Alignment

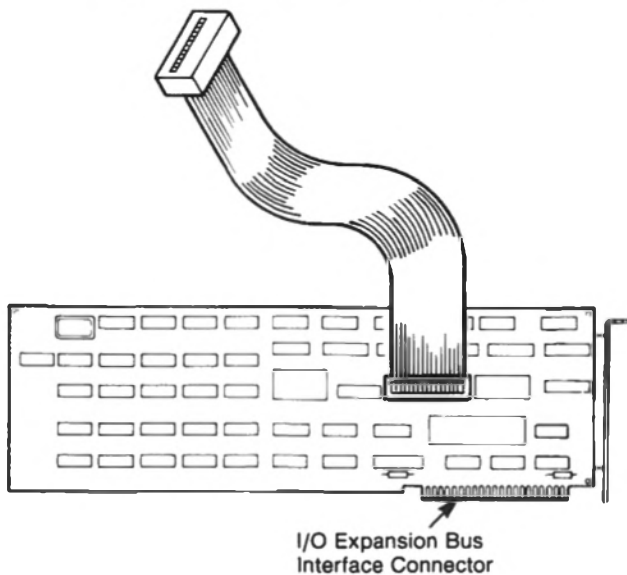

Figure 3-7 Feature Cable Attachment

7. If the feature you are installing has a cable to be attached to the controller board, then connect it at this time (see Figure 3-7).
8. Bring the connecting plug up to the opening in the grill at the back of the computer and attach the cable to the board. If the cable requires retaining screws, then install these now (see Figure 3-8).

9. Replace the plastic retaining strip removed in Step 3.

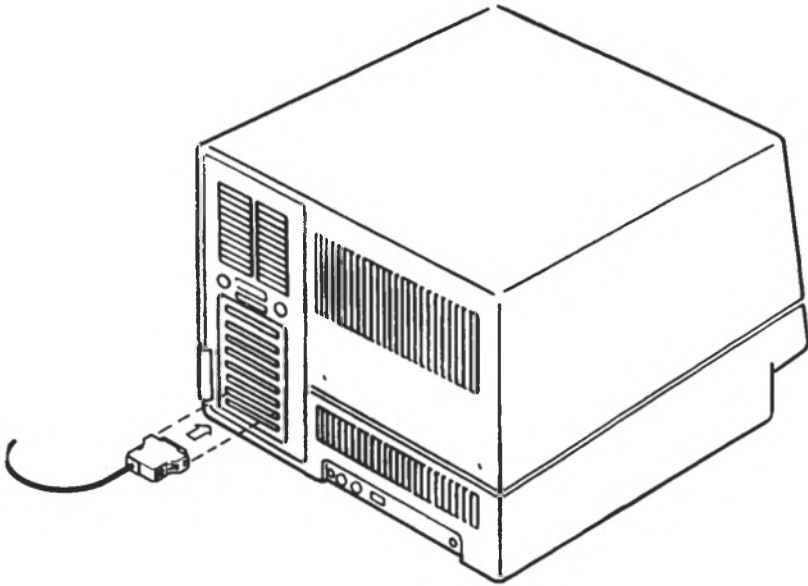

Figure 3-8 Option Cable Attachment

## BOARD REMOVAL

Carefully read the instructions in the preparation section at the beginning of this chapter and heed the **WARNING** and **CAUTIONS**, then proceed as follows to remove a board from your computer:

1. Remove the card rack assembly; refer to the cabinet disassembly instructions in this chapter.
2. Remove the screw holding the board retaining bracket (refer to Figure 3-6).
3. Remove the plastic retaining strip.
4. Disconnect any cables leading from the board to another connection (refer to Figure 3-7).
5. Rock the board slightly while keeping a constant pulling pressure on it (see Figure 3-9).
6. Replace the mounting screw in the bracket mount and tighten.

- If you plan to save the board for future use, put the board back in the antistatic plastic bag it came in to protect it from dust and static. If you are removing the board temporarily to get at the MPB, set it aside out of the way.

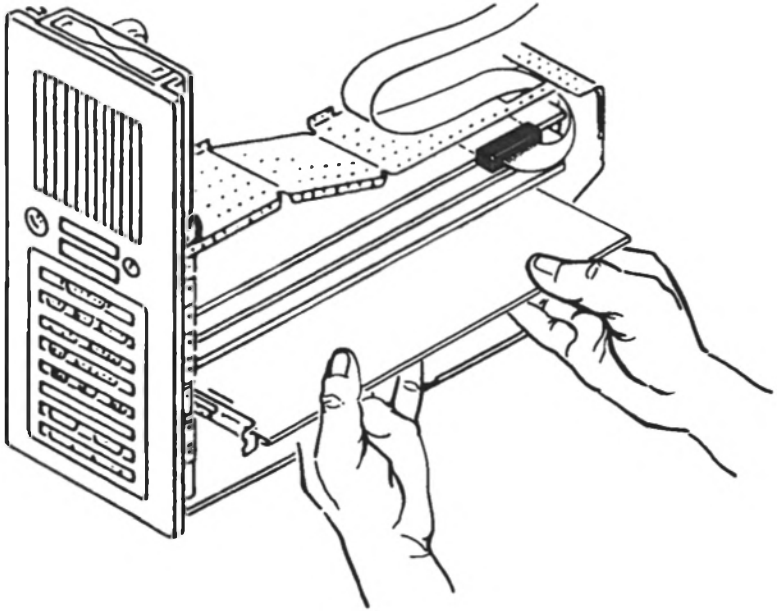

Figure 3-9 Board Removal

### **Monochrome Monitor Adapter Board (Freestanding Display)**

You can add a freestanding display when you install the Monochrome Monitor Adapter Board. This adapter board is used to drive a freestanding monochrome display but it is not suitable for connection to the integrated display of your personal computer.

You activate the option when you reset the switches in the first switch block SW1 (see Figure 3-10). The switches 5 and 6 on the SW1 block indicate the type of monitor. Using a ball-point pen, or a similar object, set switches 5 and 6 to OFF to use a monochrome display (see Figure 3-11). Leave the remaining switches set as they are.

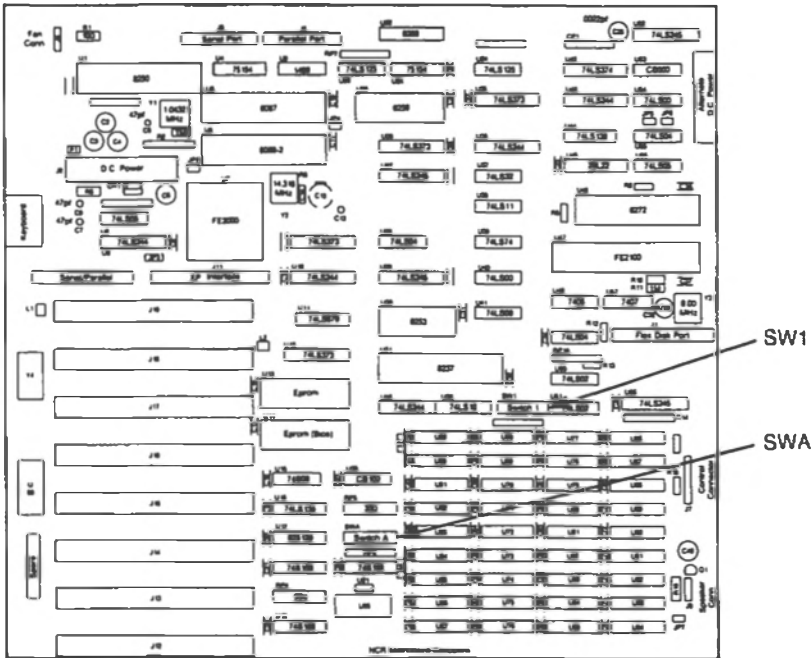

Figure 3-10 Monochrome Display Switch Block

This feature board can be used in a system that is already supporting a color display. You must set the switches on the MPB so that the computer starts in the monochrome mode to prevent possible damage to the displays.

The switch settings are:

SW1 switches 5 and 6 to OFF.

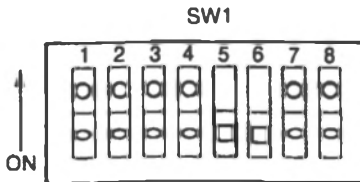

Figure 3-11 Monochrome Board Switch Settings



## **Color Display/Graphics Display Board (Freestanding Display)**

You can add a freestanding display when you install the Color/Graphics Display Adapter board. This adapter is not suitable for connection to the integrated display on your computer.

You can use the board with a color display or to enable your external monochrome display to function with graphics software. There are two video output connectors available from this board which can be used in the following manner:

1. RGB output — A color display must be used with the 9-pin D-Shell connector of the RGB (Red, Green, Blue) outlet, and this connector must be used for a standard color video display.
2. Composite video output — An RCA phono-jack connector that can be used to connect the following:
  - a. The RCA phono-jack connector can be used with a modulator to connect a television set for a display. Connect one end of a modulator to the phono-jack connector and connect the other end of the modulator to a color television.
  - b. The RCA phono-jack connector can be used to connect a composite monochrome video display.
  - c. The RCA phono-jack connector can be used to connect a composite color display.

The RGB color display can be used in any of three modes:

1. Low resolution 160 x 100 pixels GW-BASIC command: SCREEN 0
2. Medium resolution 320 x 200 pixels GW-BASIC command: SCREEN 1
3. High resolution 640 x 400 pixels GW-BASIC command: SCREEN 2

Low and medium resolution modes display color/graphics. High resolution mode displays only in monochrome.

If you have two displays in the system, one color and one monochrome, the switches must be set for monochrome to prevent possible damage to the monochrome display.

The SW1 switch setting is: 5 and 6 to OFF

Leave the other switches set as they are. In this position, when you turn on your system the monochrome display is activated. You must use your NCR-DOS mode commands to switch to the color display.

If you do not have a monochrome display in your system, change the switches to the appropriate setting (see Figure 3-12). The SW1 switch location is shown in Figure 3-10.

The SW1 switch settings for are:

Color/Graphics (40x25) 5 OFF and 6 ON

Color/Graphics (80x25) 5 ON and 6 OFF

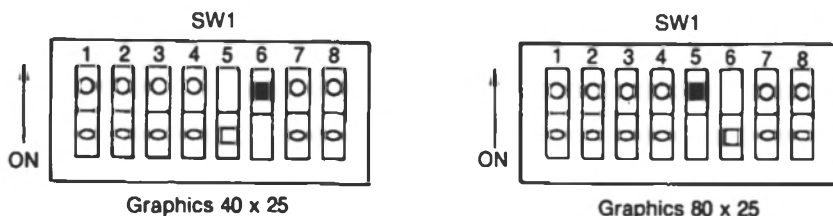

Figure 3-12 Freestanding Color/Display Switch Settings

### Alpha Controller Board (Internal Display)

Your computer is delivered with this board installed when you order a unit with one flexible disk drive and a monochrome display. The controller board provides both text and block graphics.

This feature board can be used in a system that is also supporting a freestanding color display. Refer to the board installation section to install the board and set the switches on the MPB so that the computer starts in the monochrome mode to prevent possible damage to the displays (see Figure 3-13). The SW1 location on the MPB is shown in Figure 3-10.

The switch settings are:

SW1 switches 5 and 6 to OFF.

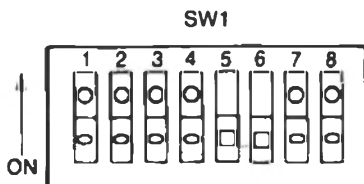

Figure 3-13 Monochrome Display Switch Settings

Plug the cable from the display into the 9-pin connector on the board and tighten the two connector screws (see Figure 3-14).

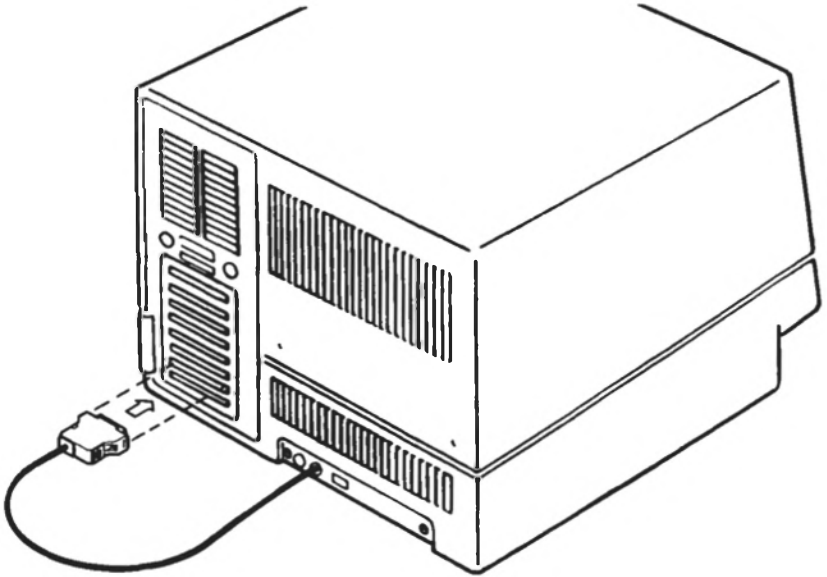

Figure 3-14 Display Connector

### **32K/64K Graphics Controller Boards (Internal Display)**

The 32K high-resolution graphics controller board can be installed in a computer with either a monochrome or color display. This controller is supplied as a standard feature except on Model 3277-1101. It supports both text and bit-mapped graphics in a range of colors on a color display, or in shades of gray on a monochrome display.

The optional 64K graphics controller board is similar to the 32K controller board, but provides displays with a higher resolution.

The switch settings are made according to your system arrangement (see Figure 3-15). If you have a monochrome and a color display in your system, the switches must be set for monochrome to prevent possible damage to the display. The NCR-DOS MODE command is used to switch to the color display.

The SW1 switch setting is: 5 and 6 to OFF

If you have a color display in your system, change the switches to the appropriate setting as shown below. The SW1 switch location is

shown in Figure 3-10. Also, you must set the jumper J1 to the correct setting (see Figure 3-16).

The SW1 switch settings are:

- Color/Graphics (40×25)      5 OFF and 6 ON
- Color/Graphics (80×25)    5 ON and 6 OFF

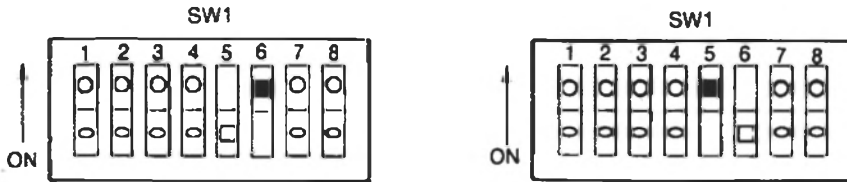
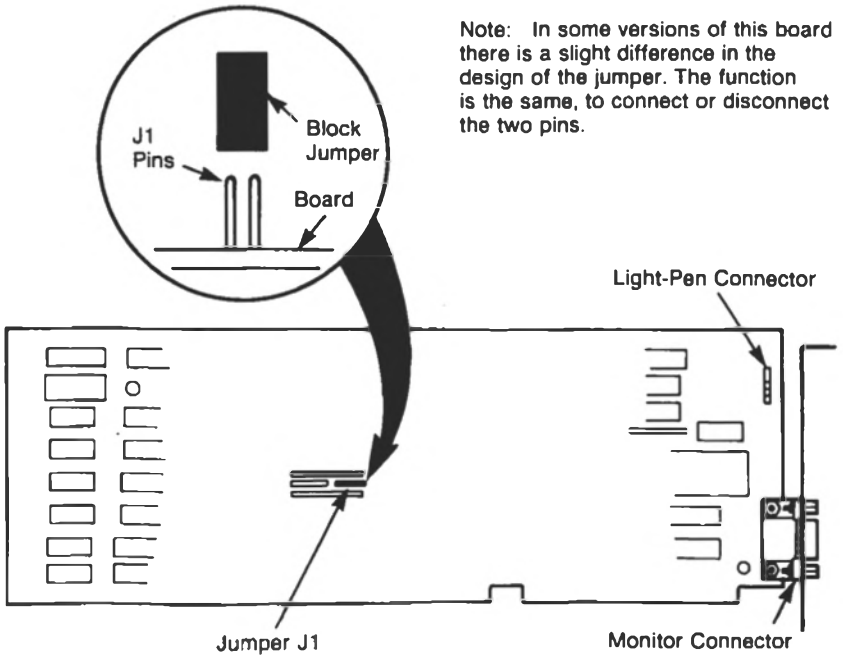

Figure 3-15 Color/Graphics Board Switch Settings

Remove the jumper block for an open position and leave the jumper block in place on J1 for a closed position.

- The jumper settings are:    Color            J1 Open
- Monochrome    J1 Closed

**NOTE:** There are two similar but slightly different designs of the jumper device. One design is shown in Figure 3-16. The function is the same for both.



Note: In some versions of this board there is a slight difference in the design of the jumper. The function is the same, to connect or disconnect the two pins.

Figure 3-16 Color/Graphics Board Jumper Location

Plug the cable from the display into the 9-pin connector on the board and tighten the two connector screws (see Figure 3-17).

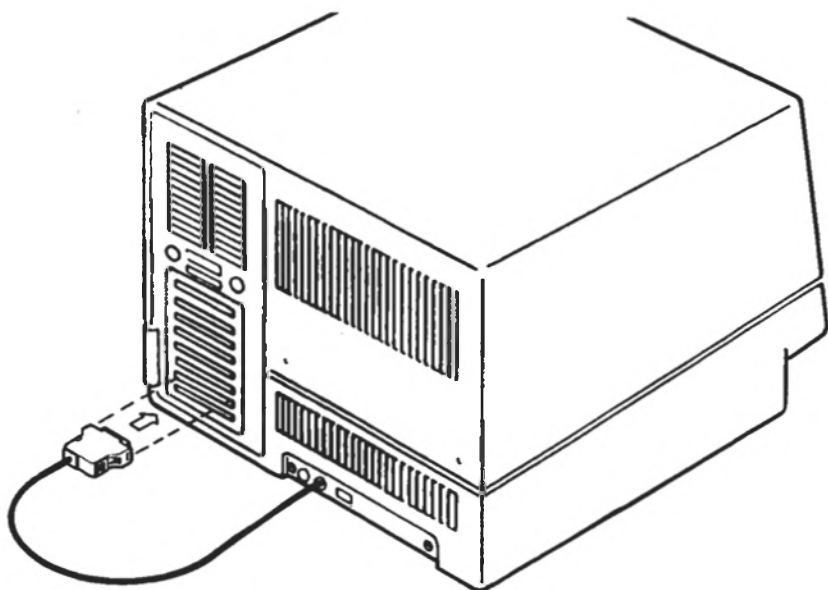

Figure 3-17 Display Connection

### **32K Graphics Controller Board Memory Expansion**

The Four chips can be installed on the 32K Controller Graphics Board to increase the memory capacity to 64K graphics memory. You need to remove the controller board to get at the chip sockets.

Refer to the cabinet disassembly section in the front of this chapter for instructions to remove the card rack assembly. Then follow the instructions given in the expanded memory section of this chapter to install the chips in the board (see Figure 3-19).

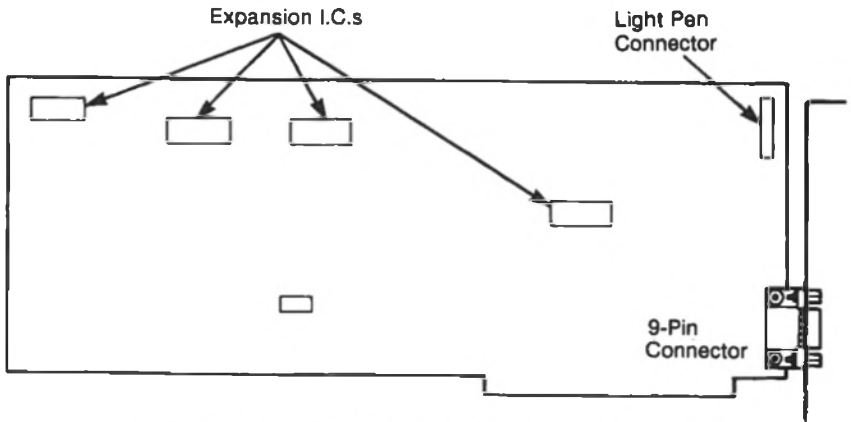

Figure 3-18 Graphics Controller Board Chip Socket Locations

### Expanded Memory

You can increase the system memory in two ways:

1. You can add 256KB chips, or 256KB and 64KB chips, on the MPB in the empty slots to bring your memory capacity up to 448 KB, 512 KB, 576 KB, or 640 KB.
2. You can purchase an expansion board and add chips in increments of 64 KB up to a system maximum of 640 KB. (NOTE: The MPB must contain sufficient chips to total exactly 256KB before a memory expansion board can be added.)

The MPB in your computer contains one of the following combinations of chips. You can add 256 KB chips and 64 KB chips in the empty slots, or substitute 256 KB chips for two banks of 64 KB chips if your computer is presently equipped with 64 KB chips, to bring your total memory capacity to 640 KB.

| Bank 0 | Bank 1 | Bank 2 | Bank 3 | Total |
|--------|--------|--------|--------|-------|
| 64     | 64     | 64     | 64     | 256   |
| 256    | 0      | 0      | 0      | 256   |

### To Install Chips:

Carefully read the instructions in the preparation section at the beginning of this chapter and heed the **WARNING** and **CAUTIONS**, then proceed to add the chips as follows:

1. Orient the pins correctly, make sure that pin 1 of the new chip is oriented the same as those already installed (see Figure 3-19).
2. Locate the specific sockets you want to use.

The chips socket locations for the MPB are shown in Figure 3-21. The memory chips on the MPB in Banks 0 and 1 may be soldered in place. You can remove the chips in Banks 2 and 3 and replace them with higher capacity chips.

If you are installing chips to an expansion board refer to that specific board for the correct socket locations (see Figure 3-22).

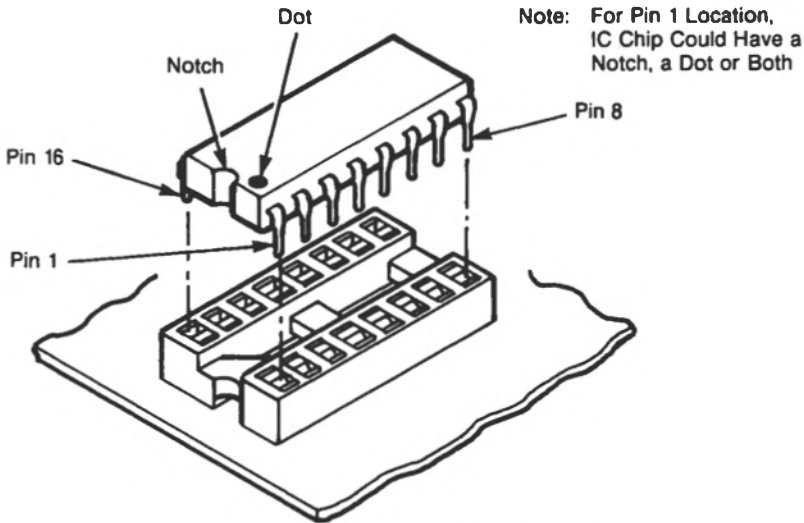

Figure 3-19 Chip Orientation

4. If the pins are too wide or incorrectly angled for the socket, press them against a surface that is both smooth and firm. Gently roll the chip until the pins are the correct angle.
5. Gently push each chip into its correct socket. Make sure that all pins are actually in the holes.
6. Set the switches on the MPB and/or expansion board as needed for your specific installation.



The switches in the switch block SWA on the MPB must be set according to the amount of memory present (see Figure 3-20).

If you use an expansion board to increase the system memory, you need to set the switches on that board (see Figure 3-22). The settings shown assume that the MPB memory totals 256 KB and the additional memory chips have been installed on an expansion board.

### Main Processor Board Memory

You can increase the memory on the MPB in several combinations of memory chips. The seven possible combinations of memory, including the two possible ways the computer is originally equipped, are shown in the chart below. The switch settings for SWA switch block are also shown in all combinations (see Figure 3-20). The chip socket locations are shown in Figure 3-21.

| Bank 0 | Bank 1 | Bank 2 | Bank 3 | SWA   |       | Configuration of Switches |
|--------|--------|--------|--------|-------|-------|---------------------------|
|        |        |        |        | No. 1 | No. 2 |                           |
| 64 K   | 64 K   | 64 K   | 64 K   | OFF   | OFF   | A                         |
| 256 K  | 0      | 0      | 0      | OFF   | ON    | B                         |
| 256 K  | 256 K  | 0      | 0      | ON    | ON    | C                         |
| 256 K  | 256 K  | 64 K   | 0      | ON    | ON    | C                         |
| 256 K  | 256 K  | 64 K   | 64 K   | ON    | ON    | C                         |
| 64 K   | 64 K   | 256 K  | 64 K   | ON    | OFF   | D                         |
| 64 K   | 64 K   | 256 K  | 256 K  | ON    | OFF   | D                         |

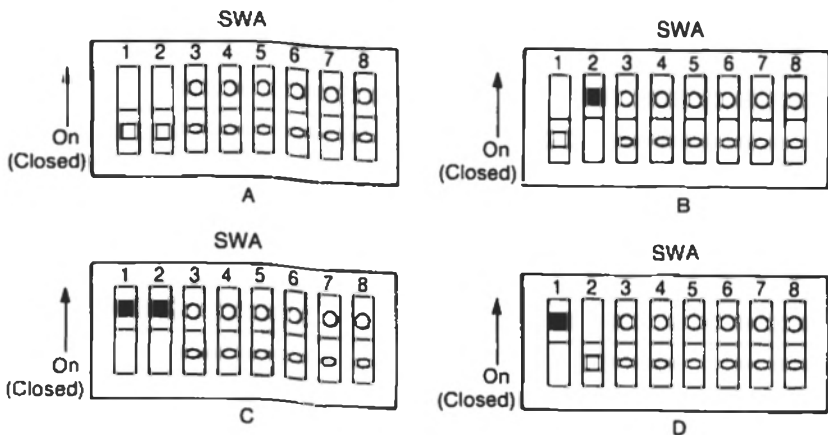

Figure 3-20 MPB SWA Switch Settings

If you are installing the additional memory to the MPB, you may need to remove boards to get to the chip sockets and switches. Refer to the cabinet removal section for instructions to remove the card rack assembly.

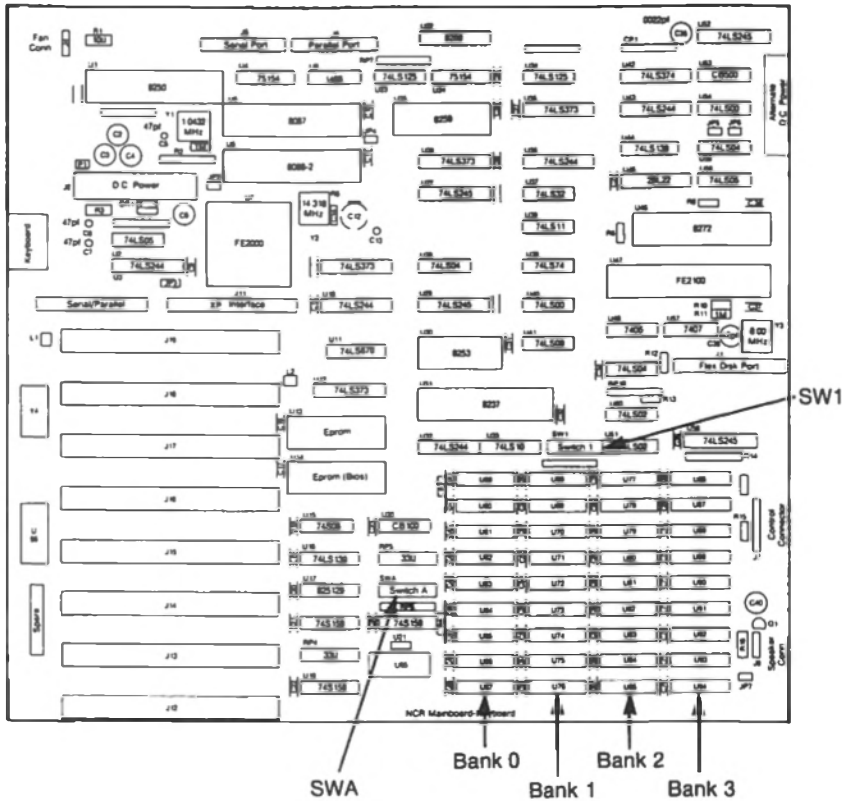

Figure 3-21 MPB Socket Locations

### Memory Expansion Board

If you are adding the memory chips to the expansion board, you need to set the switches on that board (see Figure 3-22). The settings shown assume that the MPB memory totals 256 KB and the additional memory chips have been installed on an expansion board. The chip socket locations are shown in Figure 3-23.

| Switch No. |     |     |    | Memory Size | Explanation            |
|------------|-----|-----|----|-------------|------------------------|
| 1          | 2   | 3   | 4  |             |                        |
| ON         | ON  | ON  | ON | 64 KB       | Setting as delivered   |
| OFF        | ON  | ON  | ON | 128 KB      | First 64 KB expansion  |
| ON         | OFF | ON  | ON | 192 KB      | Second 64 KB expansion |
| OFF        | OFF | ON  | ON | 256 KB      | Third 64 KB expansion  |
| ON         | ON  | OFF | ON | 320 KB      | Fourth 64 KB expansion |
| OFF        | ON  | OFF | ON | 384 KB      | Fifth 64 KB expansion  |

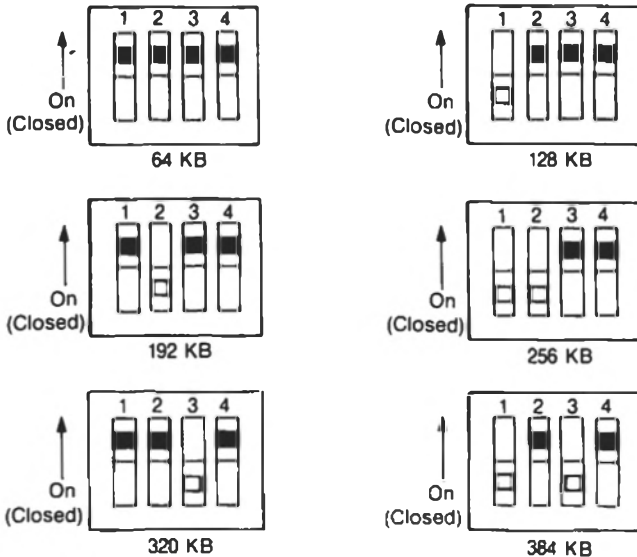

Figure 3-22 Expansion Board Switch Settings

When you install an expansion board to increase the system memory, refer to the instructions in the card rack disassembly section and in the board installation section of this chapter.

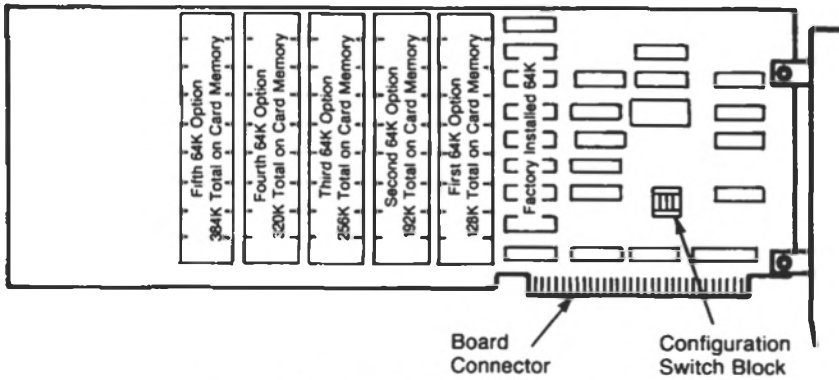

Figure 3-23 Expansion Board Socket Locations

### Numeric Coprocessor

The Numeric Coprocessor can be installed to the MPB to enhance the arithmetic capabilities of your system. Follow the instructions given in the memory expansion section of this chapter to install the chip (refer to Figure 3-19). Refer to Figure 3-25 for chip location. You need to change the switches for MPB SW1 switch block (see Figure 3-24).

|          |                           |
|----------|---------------------------|
| Switch 2 | Explanation               |
| ON       | Coprocessor not installed |
| OFF      | Coprocessor installed     |

| Switch 2 | Explanation               |
|----------|---------------------------|
| ON       | Coprocessor not installed |
| OFF      | Coprocessor installed     |

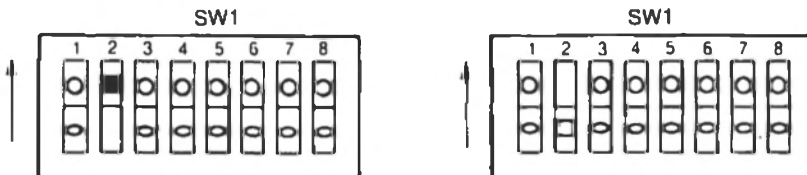

Figure 3-24 MPB SW1 Switch Settings

You may need to remove boards to get to the chip socket and switches (see Figure 3-25). Refer to the cabinet disassembly and board installation sections in the front of this chapter.

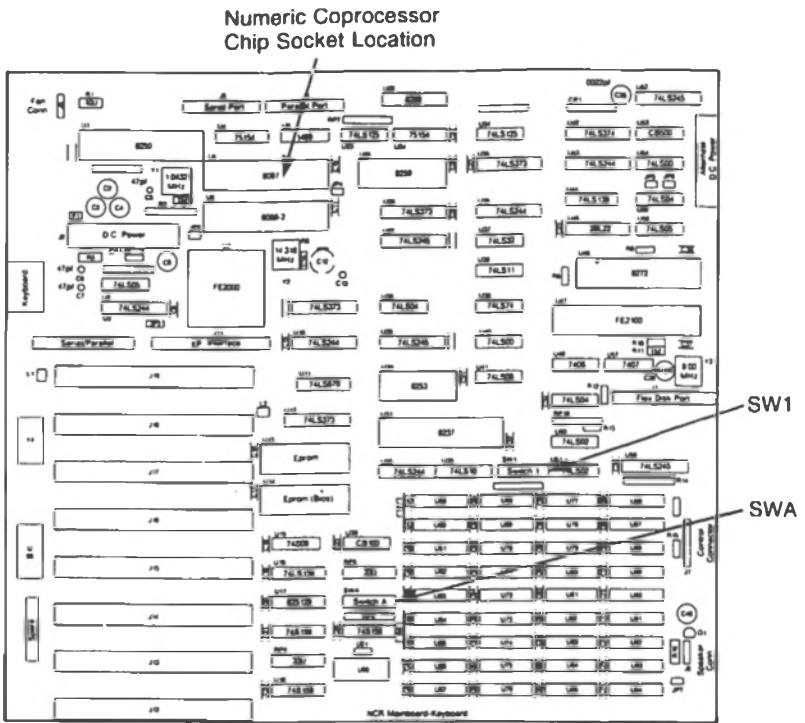

Figure 3-25 MPB Chip Socket Location

## SERIAL AND PARALLEL PORTS

The serial and parallel ports are located on the back panel of the card rack assembly. (see Figure 3-26). You use the parallel port with a parallel printer. The serial port is used to connect a serial printer, an RS232C compatible modem for telecommunications, or any other RS232 terminal device.

Carefully read the instructions in the preparation section at the beginning of this chapter and heed the WARNING and CAUTIONS, then proceed as follows:

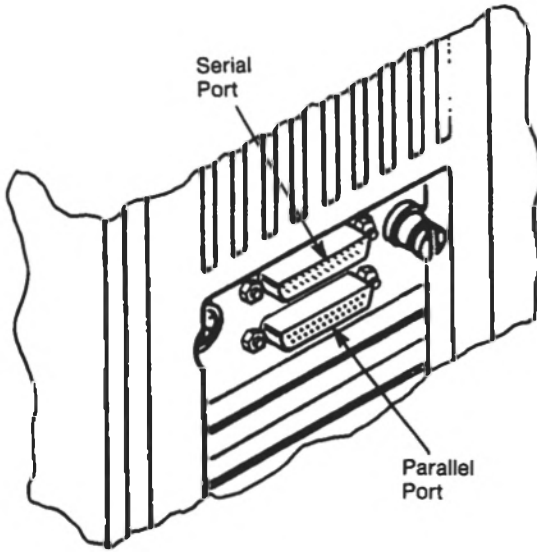

Figure 3-26 Serial and Parallel Port Receptacles

### Serial Port

The serial port is controlled by switch 3 on SWA (see Figure 3-27). Plug the serial printer connector into the serial port receptacle. Use the NCR-DOS MODE command to enable the port for a serial printer.

| Switch 3 | Explanation          |
|----------|----------------------|
| ON       | serial port enabled  |
| OFF      | serial port disabled |

| Switch 3 | Explanation          |
|----------|----------------------|
| ON       | serial port enabled  |
| OFF      | serial port disabled |

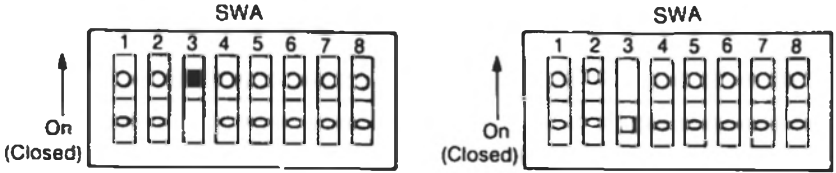

Figure 3-27 Serial Port SWA Switch Settings

### Parallel Port

Plug in the parallel printer connector to the parallel port receptacle. The parallel port (Centronics) is controlled by switch 4 on SWA (see Figure 3-28).

| Switch 4 | Explanation            |
|----------|------------------------|
| ON       | parallel port enabled  |
| OFF      | parallel port disabled |

| Switch 4 | Explanation            |
|----------|------------------------|
| ON       | parallel port enabled  |
| OFF      | parallel port disabled |

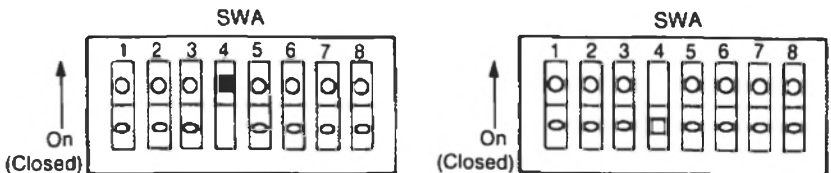

Figure 3-28 Parallel Port SWA Switch Settings

## EXTERNAL VIDEO DISPLAYS

You may have chosen to install the freestanding video display yourself rather than have the NCR representative install it. In any case, you need to set the switches on the MPB to the correct configuration and to install an adapter board. Please read all the instructions carefully before beginning the installation.

### Display Switch Settings

You may elect to use an external monochrome display, or a color display. The switches of SW1 on the MPB must be set according to the configuration you choose (see Figure 3-29).

| Switch Block SW1 |     |                       |      |
|------------------|-----|-----------------------|------|
| Switches No. 5   | 6   | Display Configuration | Fig. |
| OFF              | ON  | Graphics (40x25)      | B    |
| ON               | OFF | Graphics (80x25)      | C    |
| OFF              | OFF | Monochrome            | D    |

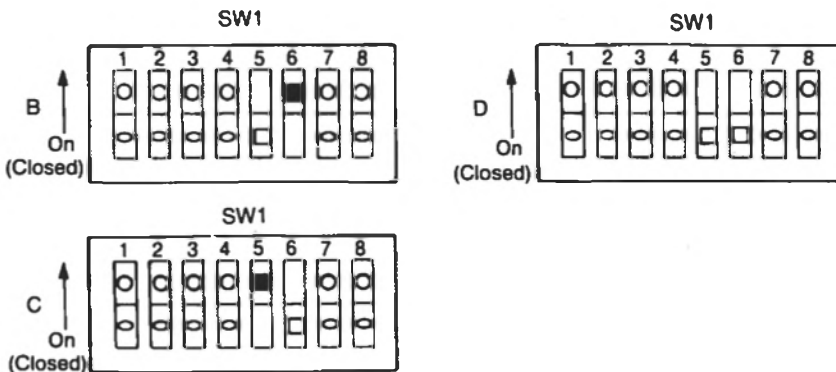

Figure 3-29 Display Switch Settings

## EXTERNAL DISPLAY INSTALLATION

Carefully read the instructions in the preparation section at the beginning of this chapter and heed the WARNING and CAUTIONS, then proceed as follows:

To install the display:

1. Set the display on the desk within cable reach of the back of the computer.



2. Install the display adapter board. Refer to the installation instructions in the display kit you chose, and to the board installation instructions in this chapter.
3. Set the appropriate switches (refer to Figure 3-29).
4. Insert the AC cord into a properly grounded outlet.
5. Connect the video cable to the adapter on the computer (refer to Figure 3-30).
6. Insert the computer's power cord into a power outlet, but leave the power switch off.
7. Turn ON the video display power switch.
8. Turn ON the computer power switch.
9. Within a few seconds a blinking cursor appears in the upper left hand corner of the display, indicating a correct installation.
10. Adjust the brightness and contrast controls to obtain optimum viewing comfort for your eyes.
11. Insert the installation booklet that came with the display into this section for future reference.

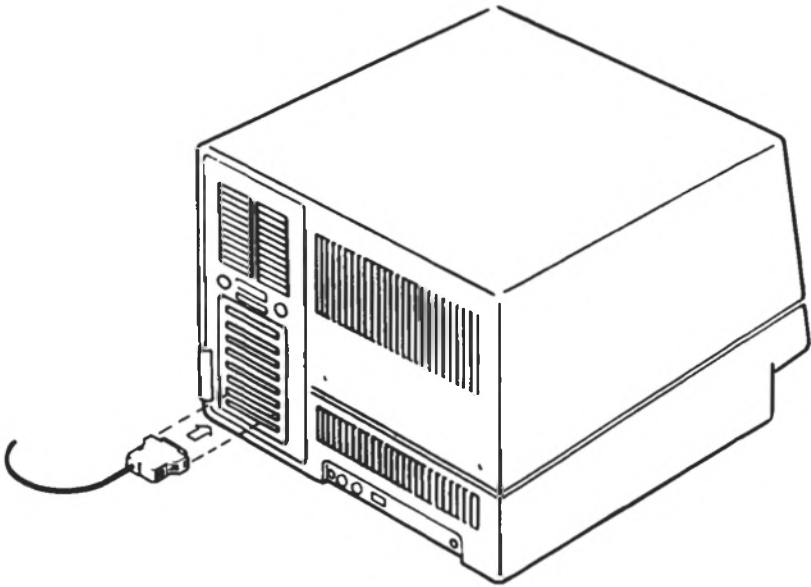

Figure 3-30 Display Cable Connections

### **FLEXIBLE DISK DRIVE**

This computer operates with a maximum of two integrated drives in the system and Drive A must be a flexible disk drive. The other drive may be either another flexible disk drive or a fixed disk drive.

The procedure for installing the flexible disk drive is straightforward. Carefully read the instructions in the preparations section at the beginning of this chapter and heed the **WARNING** and **CAUTIONS**, then proceed as follows:

1. Remove the top cover; refer to the cabinet disassembly section in the front of this chapter.
2. If you are adding a drive to an empty slot, remove the snap-out face plate (escutcheon) from the drive slot front (see Figure 3-31).
3. If you are replacing a drive, refer to the drive removal section later in this chapter.

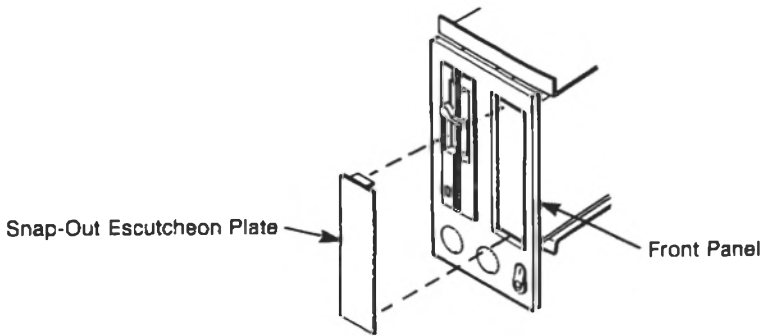

Figure 3-31 Face Plate Removal

4. Install the jumpers. Jumpers are always installed for positions PM and ML (see Figure 3-32). You must position the jumper to designate the address location of the drive in the system: DS0 (Drive A), or DS1 (Drive B).
  
5. The drive is supplied with a resistor pack J3. Leave this in place, but remove the equivalent resistor pack from Drive A.
  
6. Remove the single connector data cable from the existing drive. Remove the other end of the data cable from the MPB, if you are installing an additional drive.

Before removing the data cable from the drive or from the MPB, make a note of the cable route. The color-coded edge of the cable must always be in the correct position for the keyed connectors to mate.

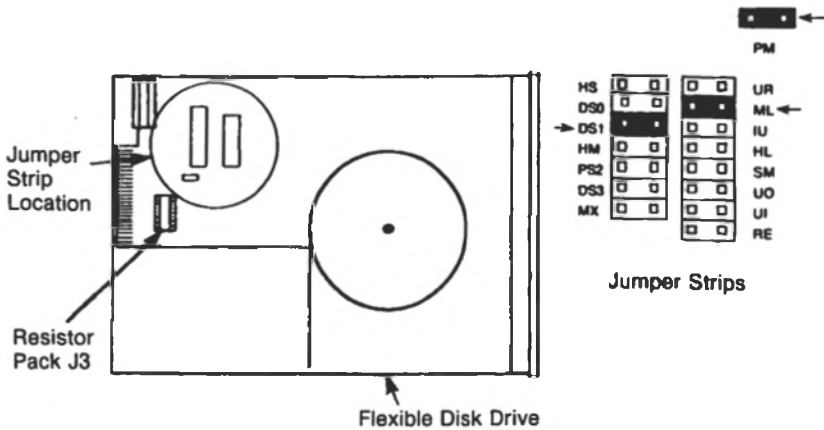

Figure 3-32 Jumper and Resistor Pack Locations

7. Insert the rear end of the drive unit into the rectangular opening in the front panel. Slide it rearward into the computer opening until the front of the drive is flush with the front computer panel (see Figure 3-33).

8. Align the top two mounting holes with the elongated slots on top of the drive bracket. Insert the two screws into the top mounting holes and drive holes and turn clockwise (see Figure 3-34).

**NOTE:** The bracket slots are elongated to allow some adjustment of the drive unit position relative to the rest of the system. If it is required, loosen the screws slightly and slide the drive unit either rearward or forward to adjust the alignment. This step is not critical to the functioning of the unit but is for cosmetic purposes.

9. Insert the remaining screw into the hole in the lower portion of the drive and turn clockwise to tighten. Some kits provide a thumb-screw for easy installation.

10. Attach one keyed connector of the data cable from the drive kit to the mating connector on the drive (see Figure 3-34).

**NOTE:** Remember to place the end connector of the data cable on the flexible disk drive with the resistor pack. Position the data cable so that the cable will not be crimped when the drive is installed completely (see Figure 3-35).

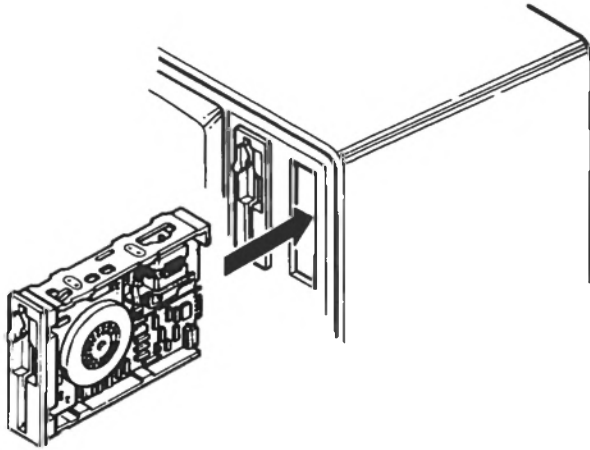

Figure 3-33 Drive Installation

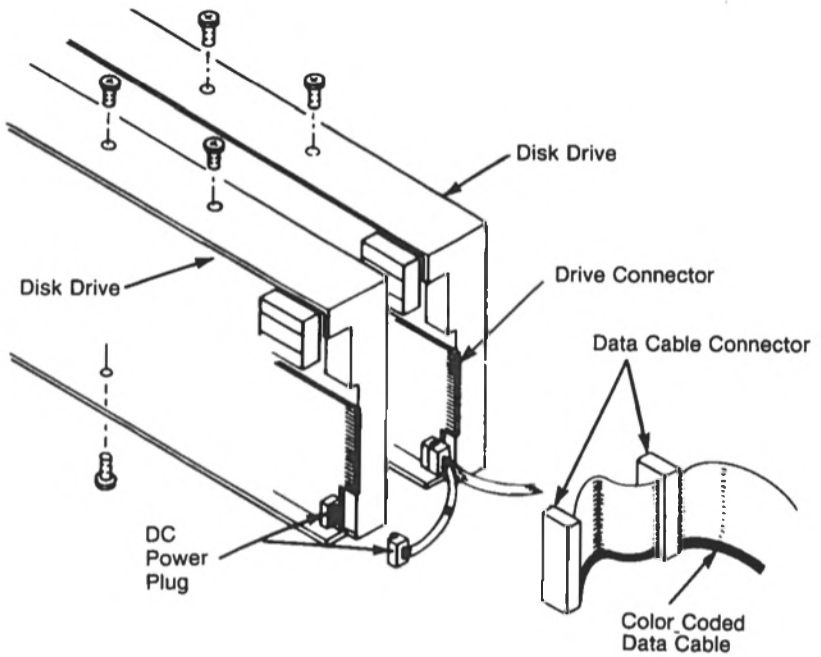

Figure 3-34 Drive Connectors

11. Attach the other connector of the data cable to the mating connector on the second drive, if you are installing an additional drive.
12. Attach the single connector end of the data cable to the mating connector on the MPB.
13. Attach the DC power plug to the receptacle at the rear of the drive unit.
14. Reassemble the cabinet; refer to the cabinet reassembly section in the front of this chapter.

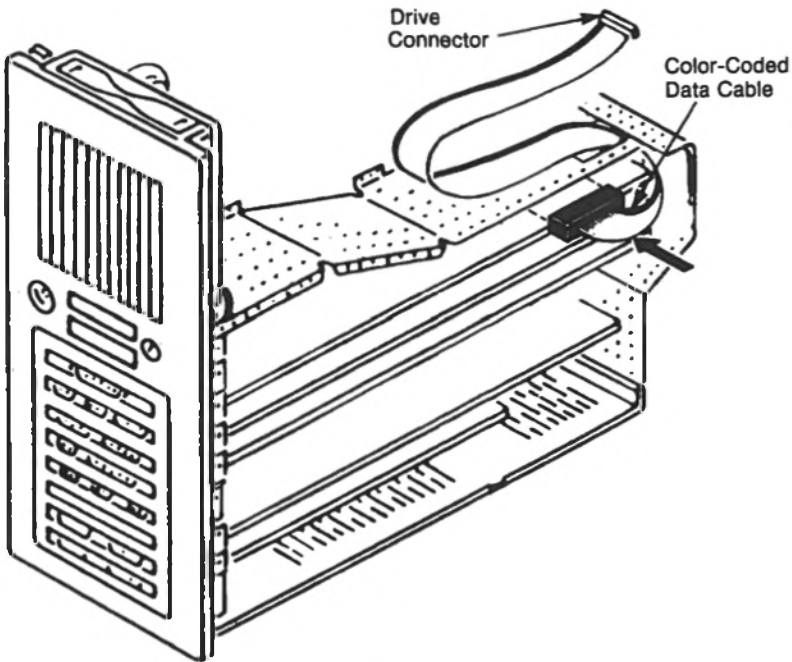

Figure 3-35 Cable Placement

### FIXED DISK DRIVE

This computer operates with a maximum of two integrated drives in the system and Drive A must be a flexible disk drive. The other drive may be either another flexible disk drive or a fixed disk drive.

The procedure for installing a fixed disk drive is simple and quick. If not previously installed, this drive requires a controller board in a joint installation.

Carefully read the instructions in the preparations section at the beginning of this chapter and heed the **WARNING** and **CAUTIONS**, then proceed as follows:

1. Remove the top cover; refer to the cabinet disassembly section in the front of this chapter.
2. If you are adding a drive to an empty slot, remove the snap-out face plate (escutcheon) from the drive slot front (see Figure 3-31).

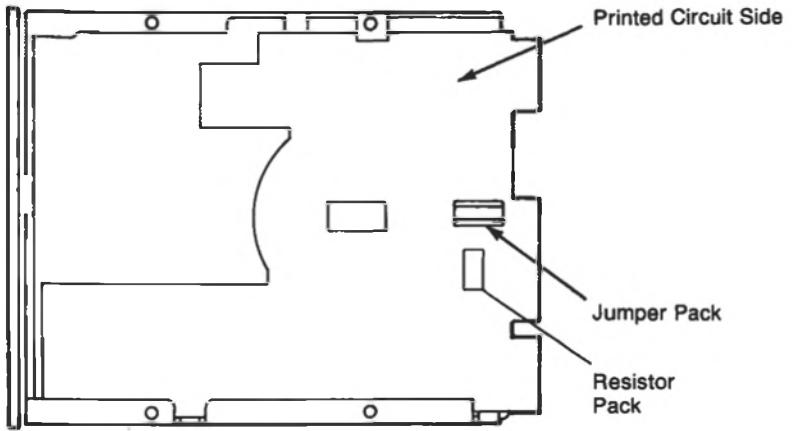

Figure 3-36 Jumper and Resistor Pack Locations

3. If you are replacing a drive, refer to the drive removal section in the back of this chapter and remove the drive.
4. Position the fixed disk drive as shown in Figure 3-36 and locate the jumper pack on the printed circuit side of the drive. Use Figure 3-37 to configure your jumper pack; cut the jumpers as follows:

4, 5, & 6

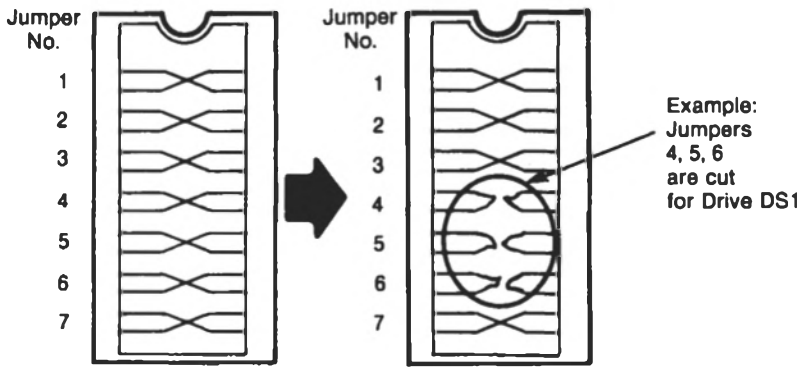

Figure 3-37 Jumper Cuts

5. Insert the rear end of the drive into the rectangular opening in the front panel (see Figure 3-38). Slide it rearward into the computer opening until the front of the drive is flush with the front computer panel.
6. Align the top two mounting holes with the elongated slots on top of the drive bracket. Insert the two screws into the top mounting holes and drive holes and turn clockwise (see Figure 3-39).

**NOTE:** The bracket slots are elongated to allow some adjustment of the drive unit position relative to the rest of the system. If it is required, loosen the screws slightly and slide the drive unit either rearward or forward to adjust the alignment. This step is not critical to the functioning of the unit but is for cosmetic purposes.

7. Insert the third screw (A) into the hole in the lower portion of the drive and turn clockwise until tight.



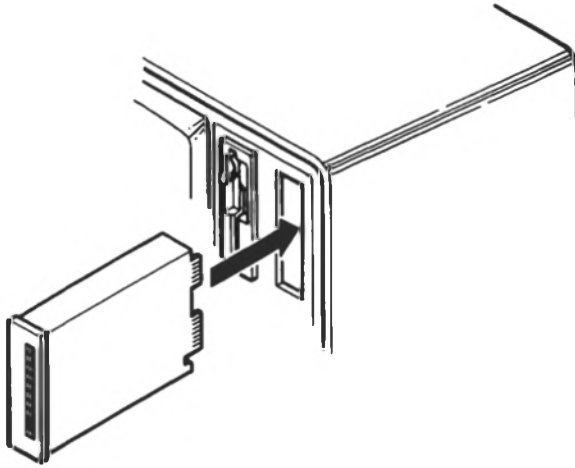

Figure 3-38 Drive Installation

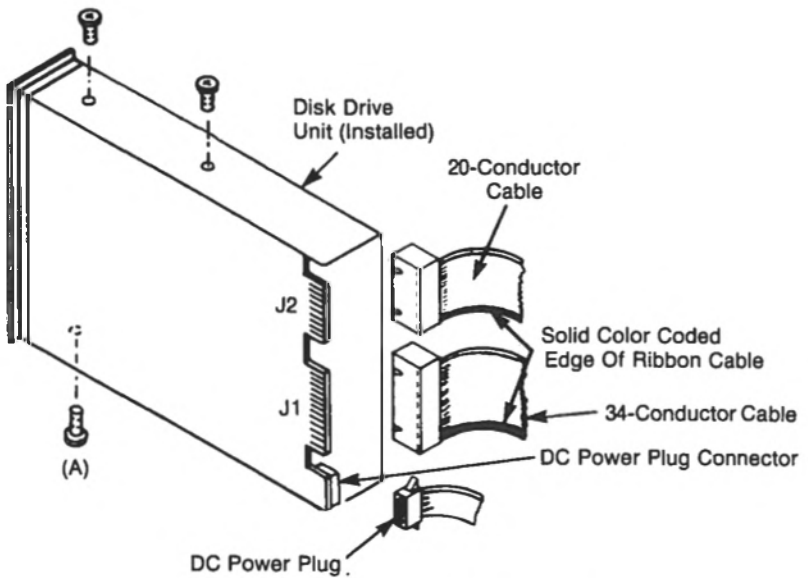

Figure 3-39 Drive Connectors

8. Attach one keyed connector of the 34-conductor controller cable to the mating connector (J1) on the drive.
9. Attach one keyed connector of the 20-conductor data cable to the mating connector (J2) on the drive.

10. Attach the DC power plug to the mating drive receptacle.

**NOTE:** Position the data cable so that the cable will not be crimped when the drive is installed completely (see Figure 3-40).

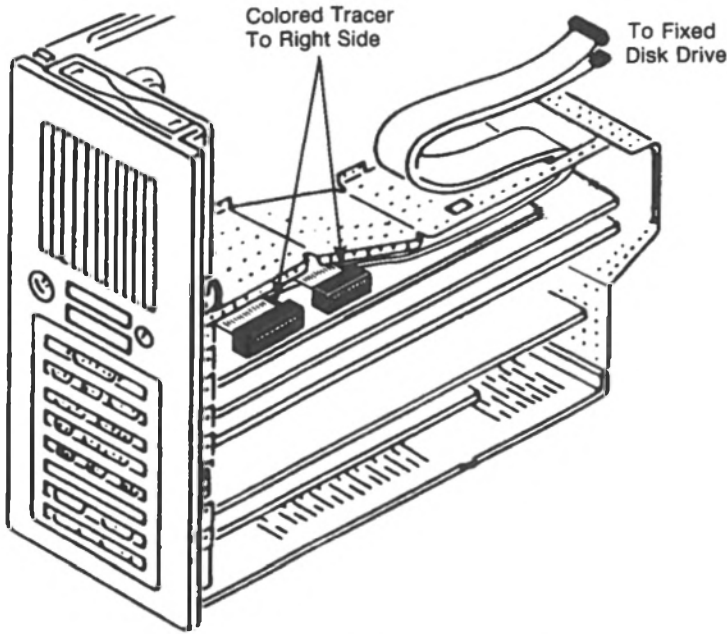
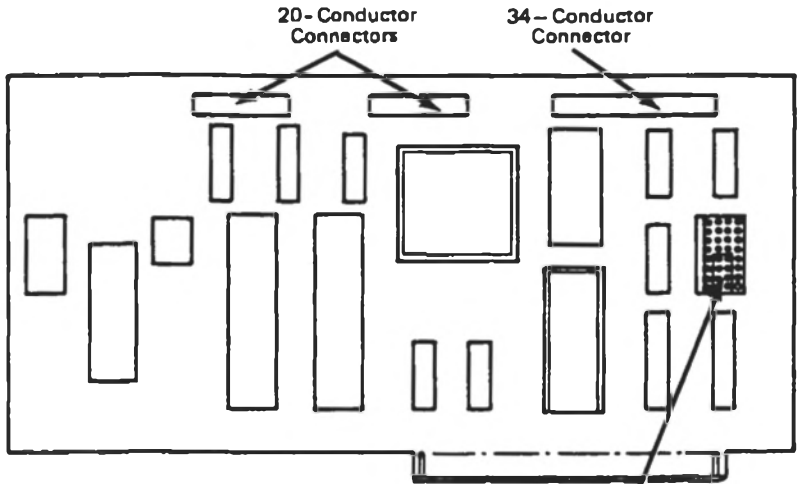

Figure 3-40 Cable Placement

If not previously installed, you must install the controller board for your fixed disk drive.

11. Take the controller board from the kit and set the jumpers as shown in Figure 3-41.
12. Install the board according to the directions in the board installation section of this chapter.
13. Connect the other end connector of the 34-conductor controller cable to the J1 controller board position.

- Connect the other end connector of the 20-conductor controller cable to the J2 or J3 board position.



0 open } - 10 MB drive  
 1 open }

0 closed } - Seagate 20 MB drive  
 1 closed }

0 closed } - other 20 MB drive  
 1 open }

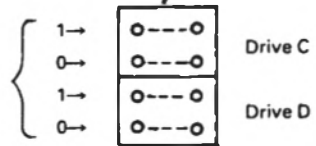

### DRIVE REMOVAL

The procedures for removing the flexible disk drive and the fixed disk drive are performed in the same manner.

Carefully read the instructions in the preparation section at the beginning of this chapter and heed the **WARNING** and **CAUTIONS**, then proceed as follows:

- Remove the top cover; refer to the cabinet disassembly instructions in this chapter.
- Disconnect the ribbon cables and the DC power plug from the drive (see Figure 3-42).

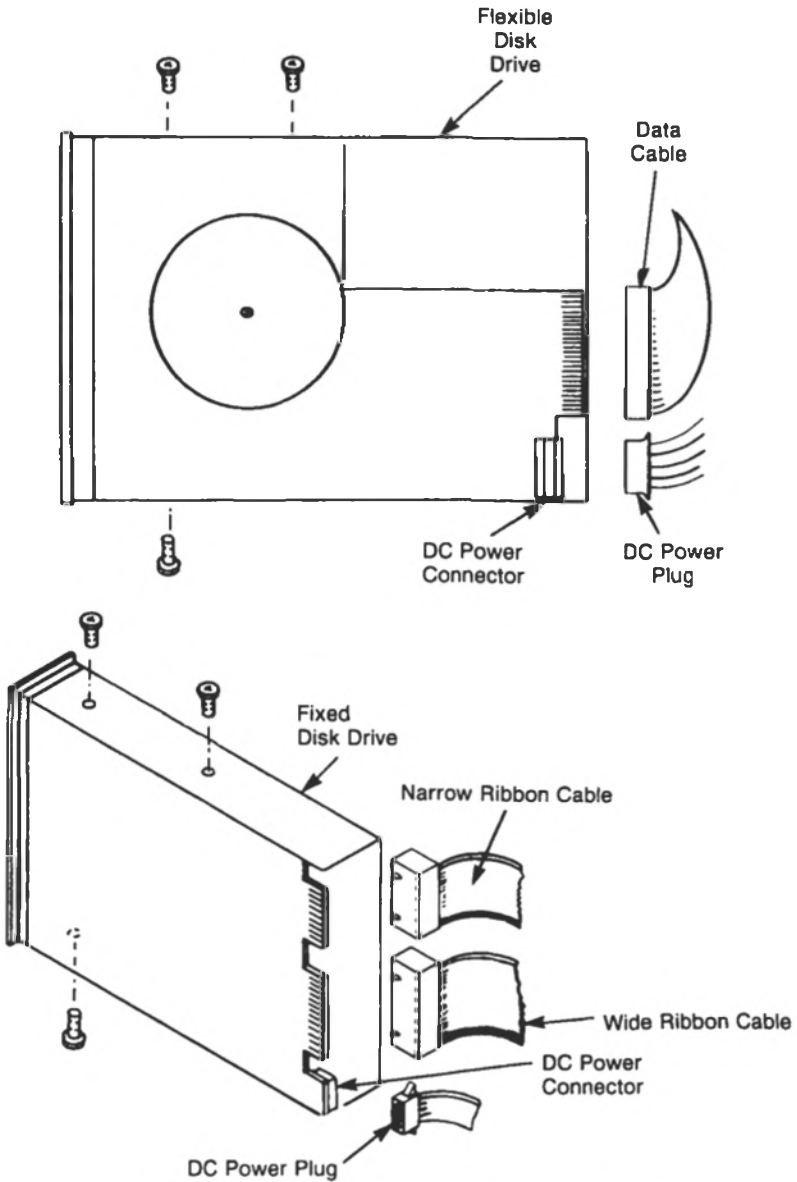

Figure 3-42 Ribbon Cable and Power Harness Removal

3. If you are removing a flexible disk drive disconnect the other end of the ribbon cable from the MPB. Do not disconnect the cable from the MPB, if you are installing a replacement drive.

If you are removing a fixed disk drive, disconnect the other end of the controller cable from the controller board that is located in the card rack assembly. Do not disconnect the controller cable if you are installing a replacement drive.

4. Remove the three screws holding the drive in position and set aside.
  5. Pull the drive through the front slot of the computer.
  6. If you removed the drive with the resistor pack, remove the pack and install it into the drive that is located at the end of the appropriate cable.
- NOTE:** The resistor pack must be located on the flexible disk drive at the end connector of the data cable and on the fixed disk drive at the end connector of the controller cable.
7. If you are replacing a drive, store the removed drive in a heavy plastic bag for safe keeping.

### **COMPUTER TILT AND SWIVEL MECHANISM**

The installation of this mechanism is simple and requires only a few preparatory steps to avert possible damage to your system. Before you move your computer, refer to the relocation section in the maintenance and troubleshooting chapter to properly prepare the drive(s) in your computer for this installation.

Carefully read the instructions in the preparation section at the beginning of this chapter and heed the **WARNING** and **CAUTIONS**, then proceed as follows:

1. Prepare the disk drives as for a move. See the relocation instructions in the Maintenance and Troubleshooting chapter.
2. Turn **OFF** the computer and disconnect all cables or cords connected to the computer.
3. Carefully turn your computer upside-down, with the display facing you.
4. Position the tilt and swivel device on the bottom of your computer so that the projections align to the hole in the computer side (see Figure 3-43). (**NOTE:** The projections and computer holes are keyed to allow only a correct installation.)

5. Rotate the base plate so that the access holes in the tilt and swivel align with the screw holes in the computer.

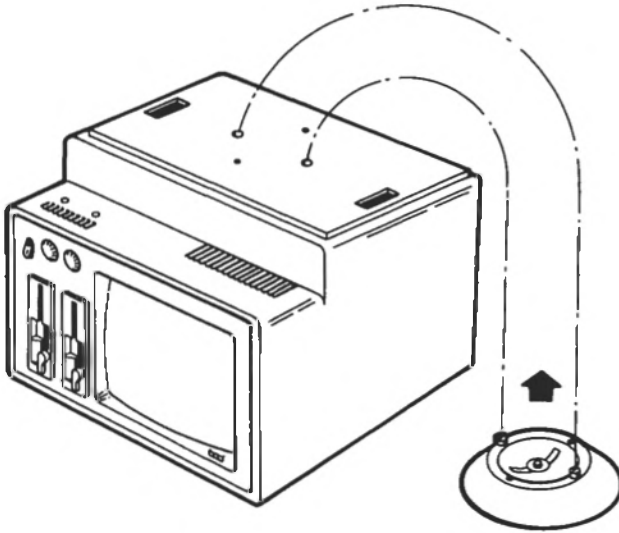

Figure 3-43 Position the Tilt and Swivel

5. Install the four screws to the bottom of the computer and turn clockwise until tight (see Figure 3-44).
6. Turn the computer upright so that it is standing on the tilt and swivel device.
7. Reconnect the cables and cords that may have been removed.
8. Make sure that you remove the inserts from your flexible disk drives upon completion of this installation.

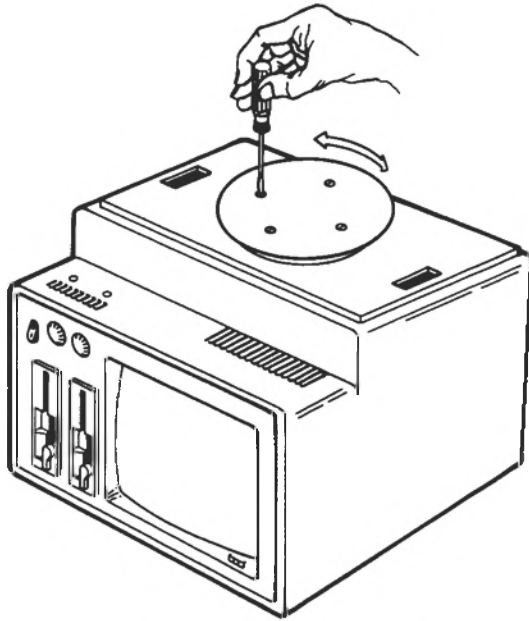

Figure 3-44 Tilt and Swivel Installation





## *Maintenance and Troubleshooting*

### **MAINTENANCE**

You can prevent many problems with your computer by daily preventive maintenance steps. Much of preventive maintenance is simple daily housekeeping:

1. Keep the unit free of dust.
2. Turn OFF your computer before connecting or disconnecting the AC power or any peripheral devices to your computer.
3. Keep food and drinks away from the computer.
4. Don't smoke in the computer area.
5. Cover the computer and any peripherals when not in use.
6. Put your diskettes away when not in use. Place them in protective envelopes and store in a closed container.
7. Check to see if any magnetized hardware is in the computer environment. Remember that magnetized objects might damage the diskettes and can affect the computer's memory. Even jewelry can have magnetic properties, so be careful.
8. Keep your computer environment as static free as possible.
9. Keep the air circulation vents uncovered (refer to Figure 2-13).
10. Remove dust that may get into the computer and affect its performance by cleaning the unit periodically. Clean the display and the cabinets (refer to Figure 2-14).
  - a. Turn OFF the power switch.

- b. Wipe the screen with a soft cloth and an ammonia-based glass cleaner, a very mild detergent solution, or a water dampened cloth. Dry the screen with a soft cloth.
- c. Wipe the cabinet with a cloth slightly dampened by a mild detergent solution, but be careful not to damage the unit by allowing liquid to get inside the cabinet.

11. Your diskettes will serve you well if you remember:

- a. Do not touch the exposed parts of diskettes.
- b. Do not bend diskettes.
- c. Do not write on the diskette labels with anything other than a soft felttip pen.
- d. Keep food, drinks, and tobacco away from them.
- e. Do not bring components that may be magnetized into the area with diskettes.

## **RELOCATION**

When you move your computer any distance there are certain steps you need to take to prepare the system. The steps are simple and could avert possible damage to your computer.

## **Flexible Disk Drive**

### **CAUTION**

Install a protective insert in each drive during a move to prevent possible severe damage to the head.

1. Put the cardboard insert that was in the drive at unpacking into the flexible disk drive. If you have not retained this, you can use an old "scratch" diskette in its place.
2. Close the drive access lever. The read/write head engages and keeps the head locked into place.

## Fixed Disk Drive

### CAUTION

Follow the instructions on your Diagnostics diskette to prepare your fixed disk for a move. The procedure takes only a minute or two and can prevent possible damage to the head.

To operate the Utilities routine from the User DIAGNOSTICS diskette (in the back of the OWNER'S MANUAL):

1. Insert the DIAGNOSTIC diskette in Drive A.
2. Turn ON the power switch.
2. Follow the instructions on the screen.

To operate the Utilities routine if you have already turned on the computer, you can follow the steps below:

1. Insert the DIAGNOSTICS diskette in drive A.
2. Hold the **Alt** key and **Ctrl** key and press the **Del** key.
3. Follow the instructions on the screen.

### Position the Fixed Head

1. From the Main Menu choose the Utilities selection <F6> (see Figure 4-1).
2. At the Utilities Menu choose the number corresponding to the wanted function — positioning the head for relocation (selection 2) (see Figure 4-2).

```

The NCR Personal Computer                               Page 1 of 2
Diagnostic Shell Version 1.0
Copyright 1985 NCR Corp.

                                MAIN MENU

Available Tests

1  Memory
2  Controllers (Circuit Devices)
3  Keyboard
4  360KB Flexible Disk Drive(s)
5  Fixed Disk Drive
6  Monochrome Display
7  Color/Graphics Display
8  Peripherals

<F1>  Explanation of Tests          <F7>  Run All Tests Once
<F6>  Utilities                    <F8>  Run All Tests Continuous
<F9>  Add/Delete Tests to Main Menu <PgUp> Previous Page
<F10> Exit to DOS                  <PgDn> Next Page

Press selection and <Enter> for running test once OR
Press selection and <F8> for continuous run of selection [ <F4> to stop]
SELECTION =>
    
```

Figure 4-1 Main Menu Screen

```

The NCR Personal Computer                               Page 1 of 1
Copyright 1985 NCR Corp.

                                UTILITIES

Available Selections

1  Initialize Fixed Disk           -Prepares Fixed Disk for DDS operations
2  Position Head for Relocation   -Positions fixed disk head for transportation
3  Error Log Maintenance          -Provides utilities for error log maintenance

<F3>  Return to previous menu     <PgUp> Previous Page
                                           <PgDn> Next Page

Press selection number and <Enter> to choose from Available Selections.
SELECTION =>
    
```

Figure 4-2 Utilities Menu Screen

3. When the head is positioned, the following message is displayed on your screen (see Figure 4-3):
4. Turn OFF the power switch. The fixed disk head is positioned in place and protected for a move.

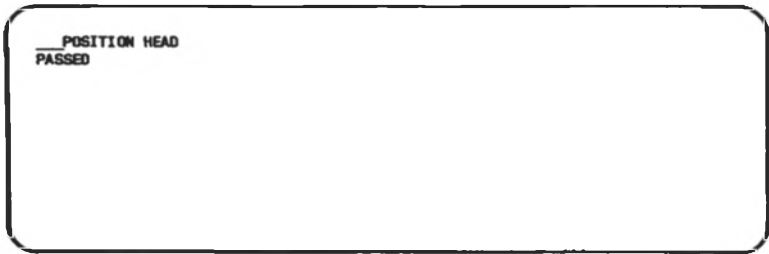

Figure 4-3 Fixed Disk Head Positioned Screen

## System

1. Turn OFF the power switches on all modules.
2. Disconnect the power cable from the outlet.
3. Disconnect all the cables from the rear of the unit.
4. Wrap the connectors with material such as foam sheets, heavy paper, etc.
5. Coil the cables and tape them securely to the computer module.

Your computer is now ready for a short move. If you are planning on a long distance move then you should take these additional precautions.

1. Put each module in its own plastic wrap.
2. Pack the modules in the original cartons and packing material.
3. Position the cushioning material about each module, and carefully place the component in its packing box.
4. To avoid damage, the modules must be packaged so they won't slide around in the boxes. Add more cushioning if necessary.
5. Tape the boxes shut with strong packing tape.

## Set-Up

Set up your system and modules at your new location according to the instructions in your Getting Started booklet and in Chapter 2 of this manual.

## **Radio/TV Interference**

This equipment generates and uses radio frequency energy and if not installed and used properly, that is, in strict accordance with the manufacturer's instructions, may cause interference to radio and television reception. It has been type tested and found to comply with the limits for a Class B computing device in accordance with the specifications in Subpart J of Part 15 of FCC Rules, which are designed to provide reasonable protection against such interference in a residential installation. However, there is no guarantee that interference will not occur in a particular installation. If this equipment does cause interference to radio or television reception, which can be determined by turning the equipment off and on, you are encouraged to try to correct the interference by one or more of the following measures:

1. Reorient the receiving antenna
2. Relocate the computer with respect to the receiver
3. Move the computer away from the receiver
4. Plug the computer into a different outlet so that computer and receiver are on different branch circuits.

If necessary, you should consult the dealer or an experienced radio/television technician for additional suggestions. You may find helpful a booklet, "How to Identify and Resolve Radio-TV Interference Problems", prepared by the Federal Communications Commission and available from the U.S. Government Printing Office, Washington DC 20402, Stock No. 004-000-00345-4.

The NCR Corporation (NCR) is not responsible for any radio or television interference caused by unauthorized modifications of this equipment or the substitution or attachment of connecting cables and equipment other than those specified by NCR. The correction of interferences caused by such unauthorized modification, substitution or attachment will be the responsibility of the user.

## TROUBLESHOOTING

### USER DIAGNOSTICS

Let's review the use and function of the User Diagnostics on the diskette packaged with this manual. You can use these Diagnostics either to identify hardware problems you encounter with your computer or to prepare your computer for a move.

You are presented with optional test selections, status and error conditions, test patterns on your display, and diskette copy instructions for this diskette.

### Copy Diagnostics

You can use your NCR-DOS program to copy the DIAGNOSTICS program to another flexible diskette.

- a. Insert your DOS diskette into drive A.
- b. Turn ON your power switch.
- c. Insert a blank diskette in drive B. (It need not be formatted.)
- d. When the **A>** appears on the screen, type **DISKCOPY A:B:** and press the **ENTER** key.
- e. The system reads from the DOS diskette the information it requires to perform the function you have asked of it. A prompt message appears on the screen:

Insert source diskette in drive A:  
Insert destination diskette in drive B:  
Press any key when ready.

- f. Follow the instructions given on the display. Remove the DOS diskette and insert the DIAGNOSTICS diskette. Press any key when ready. When the system has finished the task, a message appears on the screen to that effect. Remove the diskettes. You now have a copy of your diagnostics diskette. Put your master copy back in the protective envelope and store it in a static-free place, or insert it in the pocket at the back of this manual.

You can use your NCR-DOS program to copy your DIAGNOSTICS program to your fixed disk:

- a. Turn ON your power switch.
- b. The prompt appears on the screen.
- c. Insert the DIAGNOSTICS diskette into drive A.
- d. Key in: **COPY A:\*. \* C:** and press the **ENTER** key.
- e. When the copy is complete, a message to that effect appears on the screen.
- f. Remove the master copy of your Diagnostics from Drive A and replace it in the pocket at the back of this manual.

You now have a working copy of your Diagnostics program.

## Error Messages

### Pass/Fail Message Field

Following testing, a PASS/FAIL message appears on the right-hand side of the Main Menu screen corresponding to each test module selection. If the message opposite a module is PASSED, then the test detected no error. If the message is FAILED, then the module has detected one or more errors. A blank field means that the test on the module was not executed. You can go to the Error Log on the Utilities Menu to display or print out any FAIL messages.

If you receive an error message following any test, the procedure is:

1. Run the test again in continuous mode for a few minutes to see if the error continues to occur.
2. If no further failures occur, it is reasonable to assume that some transient condition caused the error and it is not likely to recur.
3. If the error continues to occur, regularly or intermittently, call your dealer or NCR representative for advice. Or, if you purchased a Maintenance Agreement, follow the instructions in the agreement.



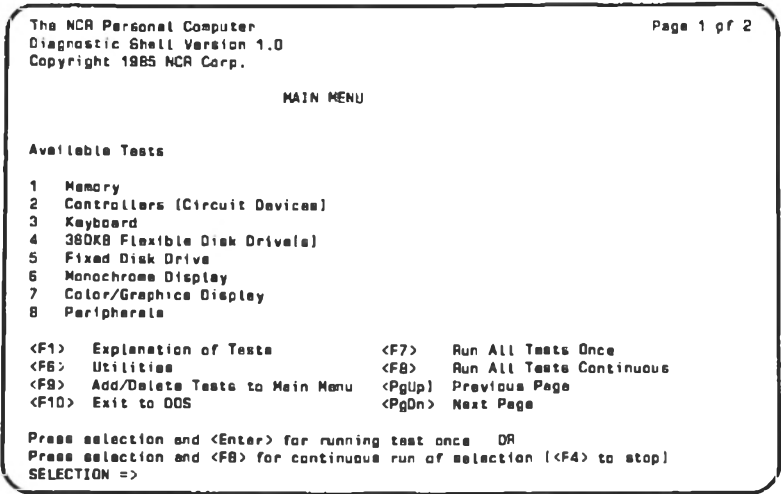

Figure 4-4 Sample Diagnostics Main Menu Screen

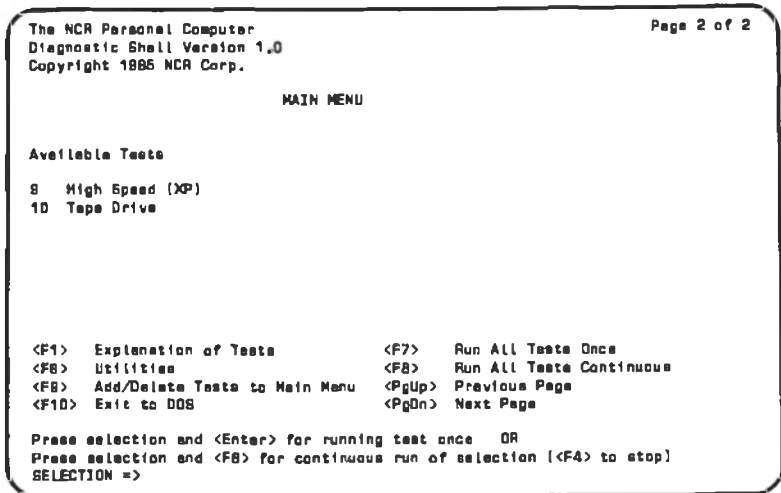

Figure 4-5 Sample Diagnostics Main Menu Screen (Page 2)

### A Typical Diagnostics Run-Through

Let's start with your new Diagnostics diskette copy. Turn On the system using the working copy diskette to start the program at the beginning. Now, the first screen is the Main Menu screen (refer to Figure 4-4). You can press the **Pg Dn** key to go to the second page of the

diagnostics program, or you can make a specific selection to run the test of your choice (see Figure 4-5). You can use the **F1** key to ask for an Explanation of Tests screen to explain the meaning of the choices (see Figure 4-6). To exit from the Diagnostics program, press the **F10** key. This takes you out of the Diagnostics program.

Let's take it from the top and run every test one time. When you select a test and press **ENTER**, the test runs once and stops. If you select a test and press the **F8** key, the test will repeat automatically (Continuous Mode) until you stop it by pressing the **F4** key.

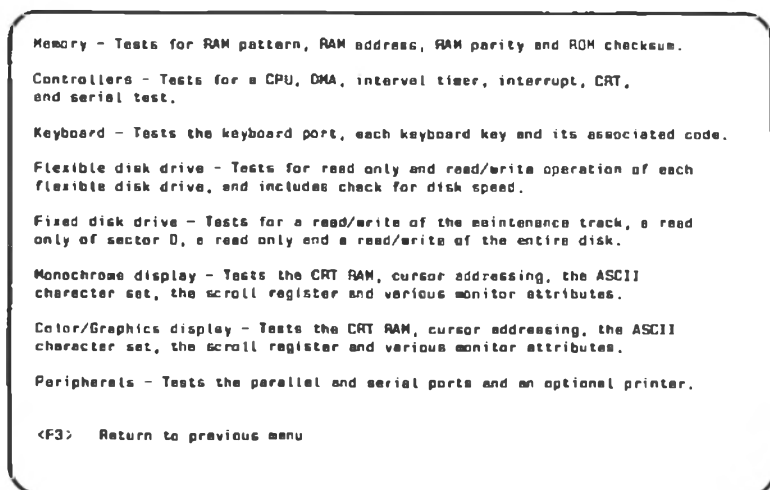

Figure 4-6 Sample Main Menu Help Screen

## Memory Test

When you choose the Memory Test, selection 1 on the Main Menu screen, the System Memory screen is displayed (see Figure 4-7). The program tests the memory for the various characteristics and displays a message as each one passes the test. If any of the characteristics of the memory fails the test, one or more of the messages shown in Figure 4-8 will be displayed.

```

The NCR Personal Computer                                Copyright 1985 NCR Corp.

                                MEMORY
                        Installed Memory = xxx KB

__RAM PATTERN
PASSED
__RAM ADDRESS
PASSED
__RAM PARITY
PASSED
__FIRMWARE CHECKSUM
PASSED

<F2> Terminate Test Module
    
```

Figure 4-7 Memory Test Screen

```

MEMORY           (date) (time)
RANDOM ACCESS MEMORY (RAM) PATTERN ERROR

MEMORY           (date) (time)
RANDOM ACCESS MEMORY (RAM) ADDRESS ERROR

MEMORY           (date) (time)
RANDOM ACCESS MEMORY (RAM) PARITY ERROR

MEMORY           (date) (time)
READ ONLY MEMORY (ROM) CHECKSUM ERROR
    
```

Figure 4-8 Memory Error Message Screen

### Controllers Test (Circuit Devices)

When you choose the Controllers Test, selection 2 on the Main Menu screen, the Controllers Messages screen is displayed (see Figure 4-9). The program tests each of the controllers in the system and displays a message as each one passes the test. If any of the controllers fail the

test, one or more of the messages shown in Figure 4-10 will be displayed.

```

The NCR Personal Computer                                     Copyright 1985 NCR Corp.

                                CONTROLLERS

__ CPU
PASSED
__ DMA
PASSED
__ FLEXIBLE DISK
PASSED
__ INTERVAL TIMER
PASSED
__ INTERRUPT CONTROLLER
PASSED
__ CPU CONTROLLER
PASSED
__ CRT, MONO
PASSED
__ SERIAL
PASSED

<F2> Terminate Test Module
    
```

Figure 4-9 Controllers Test Screen

```

CONTROL      (date)  (time)
CENTRAL PROCESSING UNIT (CPU) ERROR

CONTROL      (date)  (time)
DIRECT MEMORY ACCESS (DMA) CONTROLLER ERROR

CONTROL      (date)  (time)
FLEXIBLE DISK CONTROLLER BOARD ERROR

CONTROL      (date)  (time)
INTERVAL TIMER ERROR

CONTROL      (date)  (time)
INTERRUPT CONTROLLER ERROR

CONTROL      (date)  (time)
CPU CONTROLLER ERROR

CONTROL      (date)  (time)
MONOCHROME CRT CONTROLLER BOARD ERROR

CONTROL      (date)  (time)
COLOR CRT CONTROLLER BOARD ERROR

CONTROL      (date)  (time)
SERIAL PORT (COM1) ERROR
    
```

Figure 4-10 Controllers Error Message Screen

### Keyboard Test

When you choose the Keyboard Test, selection 3 on the Main Menu screen, the system performs a keyboard port test and a status message is displayed on the screen along with the keyboard verification test (see Figure 4-11).

The Keyboard Port test performs a port reset. If a keyboard is not attached, then the test performs a write and read on the port. If a keyboard is attached, then the test signals to the keyboard to perform its own internal diagnostics. If the keyboard self-diagnostics do not complete successfully, then the test fails (refer to Error Messages, Figure 4-12).

In the Keyboard Verification test you are prompted to press keys on the keyboard, then to verify that the keys displayed are the same as the ones you pressed. If the keys do not correspond then the program signals a keyboard error.

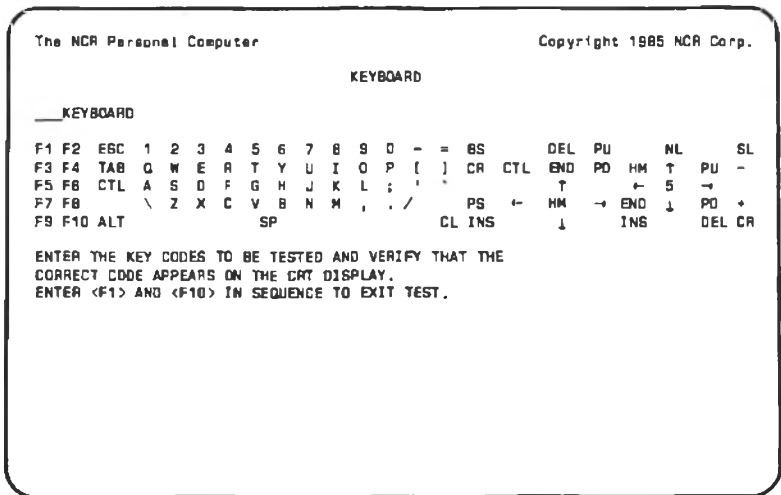

Figure 4-11 Keyboard Test Screen

```

KEYBRD      (date)      (time)
  KEYBOARD ERROR

KEYBRD      (date)      (time)
  KEYBOARD PORT ERROR
    
```

Figure 4-12 Keyboard Error Message Screen

### Flexible Disk Drive Test

When you choose the Flexible Disk Drive Test, selection 4 on the Main Menu screen, the program tests the read and write capability of all of the flexible disk drives in your system. Then it displays the Flexible Disk Drive test screen as the drives pass the test (see Figure 4-13). If any of the drives fail the test, an error message is displayed (see Figure 4-14).

The NCR Personal Computer

Copyright 1985 NCR Corp.

FLEXIBLE DISK DRIVE  
Number of drives = 2

\_\_\_ READ/WRITE, FLEXIBLE DRIVE A  
PASSED

\_\_\_ READ/WRITE, FLEXIBLE DRIVE B  
PASSED

WARNING - This is a destructive test to any diskette other than the diagnostic diskette.

Place a diskette in all of your disk drives.

Press any key to continue OR <F2> to terminate test module:

Figure 4-13 Flexible Disk Drive Test Screen

```

FLEX          (date)      (time)
  READ ONLY ERROR, DRIVE x

FLEX          (date)      (time)
  READ/WRITE ERROR, DRIVE x

where x is the letter of the drive with the failure.

```

Figure 4-14 Flexible Disk Drive Error Message Screen

### Fixed Disk Drive Test

When you choose the Fixed Disk Drive Test, selection 5 on the Main Menu screen, the program tests the read and write capability of the drives and displays the Fixed Disk Drive screen as each drive passes (see Figure 4-15). If any of the drives fail the test, one or more of the error messages shown in Figure 4-16 is displayed.

```

The NCR Personal Computer                               Copyright 1985 NCR Corp.

                                FIXED DISK DRIVE

__ FIXED DISK CONTROLLER
PASSED
__ READ/WRITE MAINTENANCE TRACK
PASSED
__ READ ONLY SECTOR 0
PASSED

<F2> Terminate Test Module

```

Figure 4-15 Fixed Disk Drive Test Screen

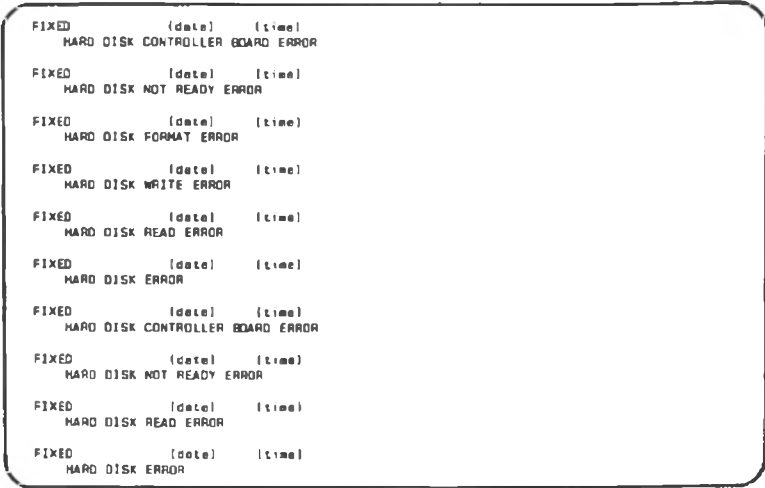

Figure 4-16 Fixed Disk Drive Error Messages

### Monochrome Display Test

When you choose the Monochrome Display Test, the program tests five different characteristics of the display and shows five messages in succession as the characteristics are passed (see Figure 4-17). If any of the characteristics fail the test, one or more of the error messages shown in Figure 4-18 is displayed.



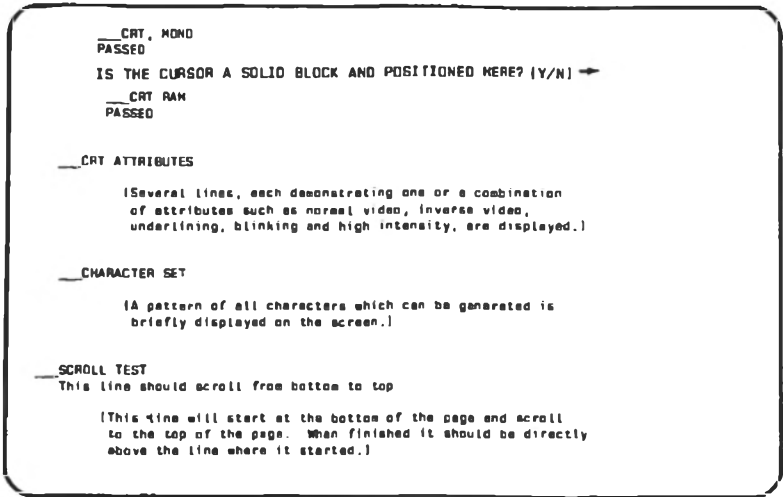

Figure 4-17 Monochrome Display Tests Screen

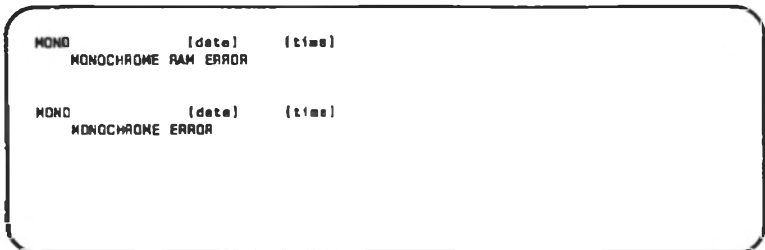

Figure 4-18 Monochrome Display Error Messages

### Color/Graphics Display Test

When you choose the Color/Graphics Display Test, selection 6 on the Main Menu screen, the program tests nine different characteristics of the display and shows nine messages in succession as the characteristics are passed (see Figures 4-19 to 4-27). If any of the characteristics fail the test, the error message shown in Figure 4-28 is displayed.

\_\_\_CRT, COLOR/GRAPHICS  
PASSED

Figure 4-19 CRT Color Test Screen

\_\_\_CRT RAM

[A pattern of all characters which can be generated is briefly displayed on the screen.]

Figure 4-20 CRT RAM Test Screen

\_\_\_CRT ATTRIBUTES

[Several lines, each demonstrating one or a combination of attributes such as normal video, inverse video, blinking, high intensity, blue highlight, white on blue/red/green, blue/red/green on white, are displayed.]

Figure 4-21 CRT Attributes Test Screen

\_\_\_CHARACTER SET

[A pattern of all characters which can be generated is briefly displayed on the screen.]

Figure 4-22 Character Set Test Screen

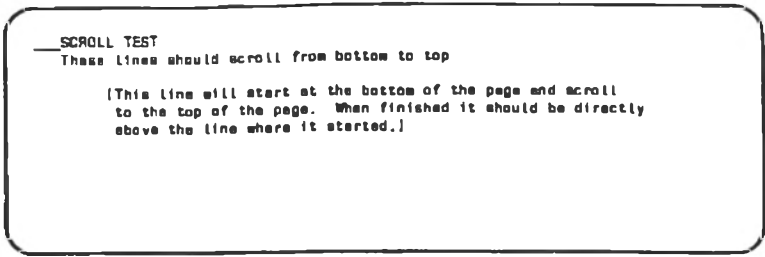

Figure 4-23 Scroll Test Screen

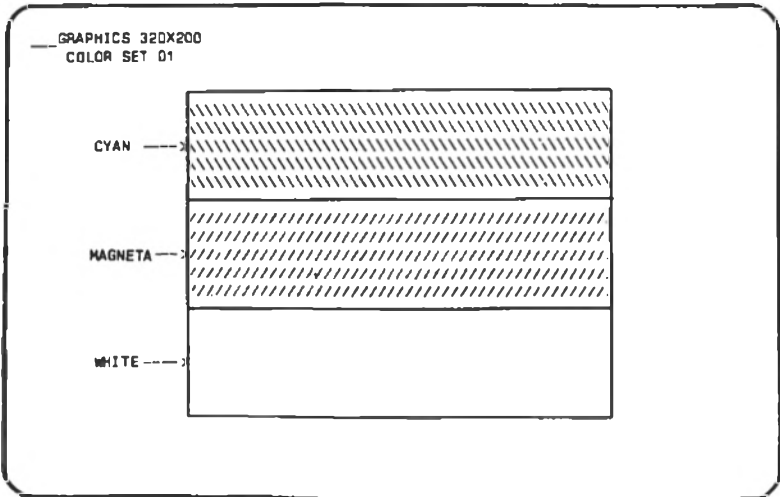

Figure 4-24 320 by 200 Graphics (First Color) Test Screen

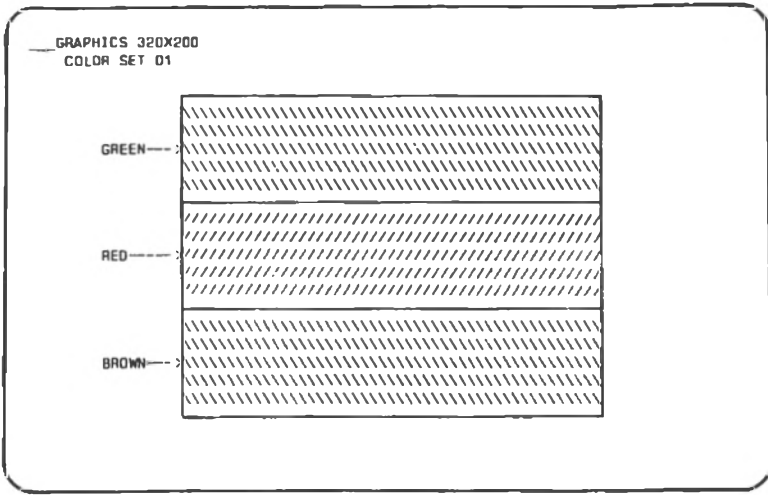

Figure 4-25 320 by 200 Graphics (Second Color) Test Screen

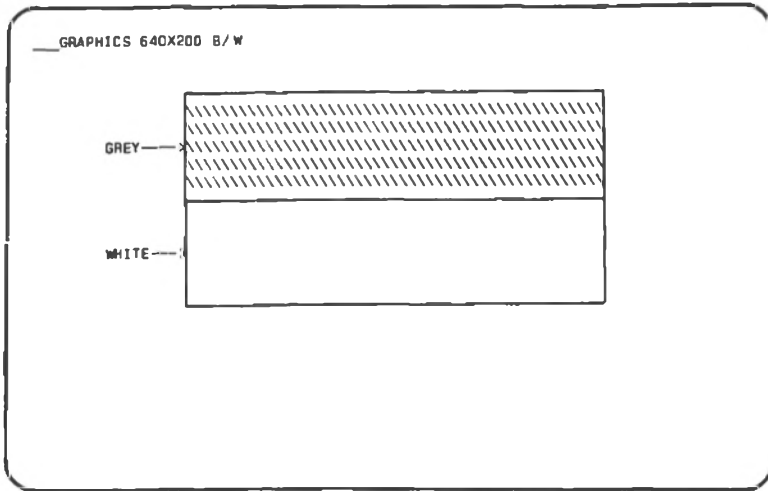

Figure 4-26 640 by 200 Graphics (Third Color) Test Screen

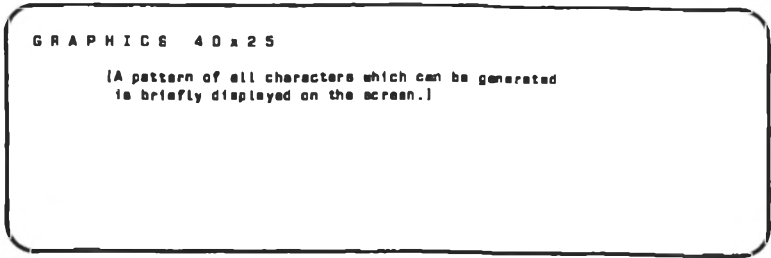

Figure 4-27 40 by 25 Graphics Test Screen

After the graphics portion of the test, a message is displayed on the screen asking if a light pen is installed. If you respond “no”, the next screen is displayed (see Figure 4-28). If you respond “yes”, the pen is tested before the next screen is displayed.

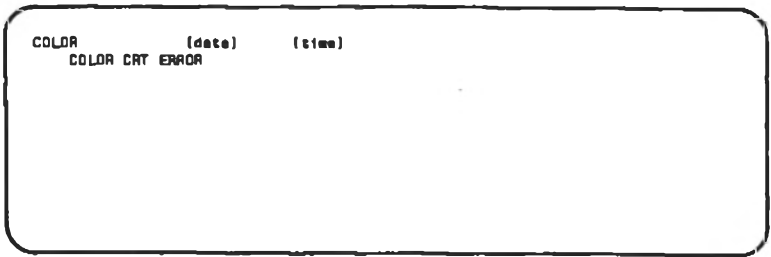

Figure 4-28 Color Display Error Message Screen

### Peripherals Test

When you choose the Peripherals Test, selection 8 on the Main Menu screen, the program tests each of the ports. (The printer test will be executed only if a printer is connected to the computer.) The test screen is displayed as each peripheral is passed (see Figure 4-29). If any of the peripheral devices fail the test, one or more of the messages shown in Figure 4-30 will be displayed.

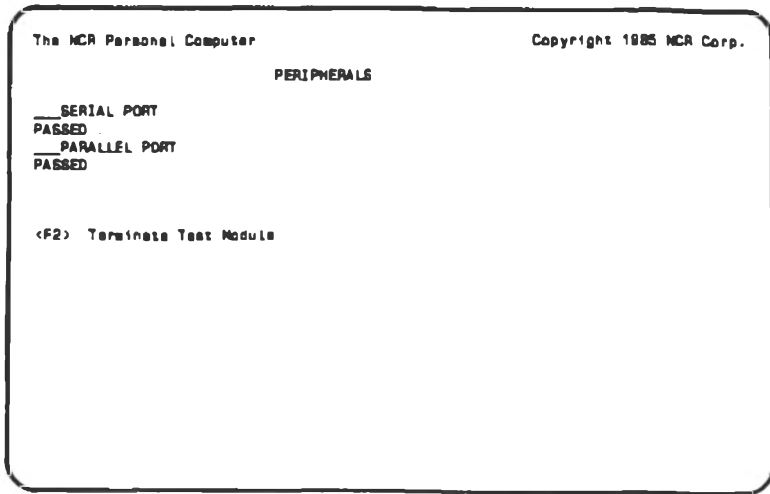

Figure 4-29 Peripherals Test Screen

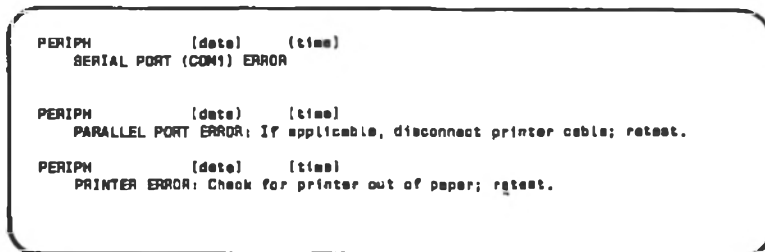

Figure 4-30 Peripherals Error Messages

### Tape Drive Test

When you choose the Tape Drive Test, selection 10 on the Main Menu screen, the program tests the read/write control. When the control passes the test the message shown in Figure 4-31 is displayed. If the tape drive fails the test, the message shown in Figure 4-32 is displayed.

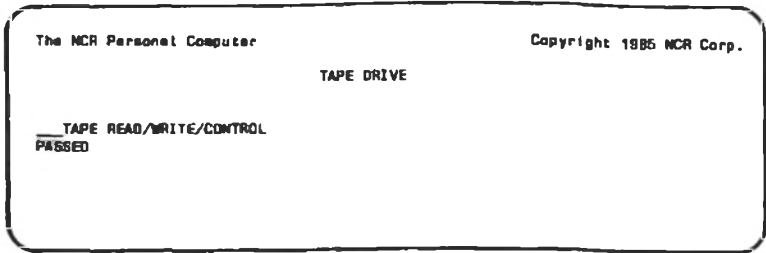

Figure 4-31 Tape Drive Test Screen

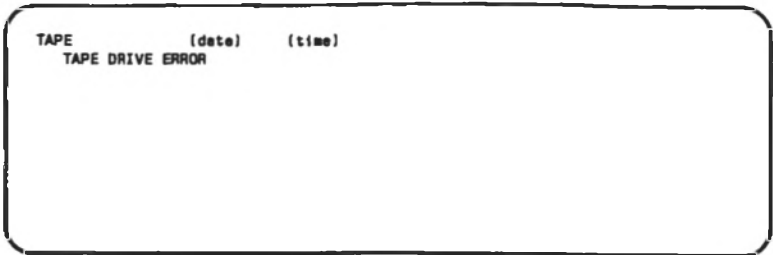

Figure 4-32 Tape Drive Error Message

### Continuous Run of Tests from Main Menu

You may select a continuous run of one or all of the tests from the Main Menu. You are not asked to respond to any prompts from this selection. The cycle continues until you cancel it by pressing the **F4** key. A continuous flow of the screens is displayed until the tests are halted. Any errors found are written to the Error Log and a message is displayed in a window to the right of the Main Menu.

### Utilities Menu

The Utilities Menu screen is displayed when you press the **F6** key from the Main Menu (see Figure 4-2 or 4-33). On this screen you have three selections from which to choose, or you may return to the Main Menu by pressing **F3**.





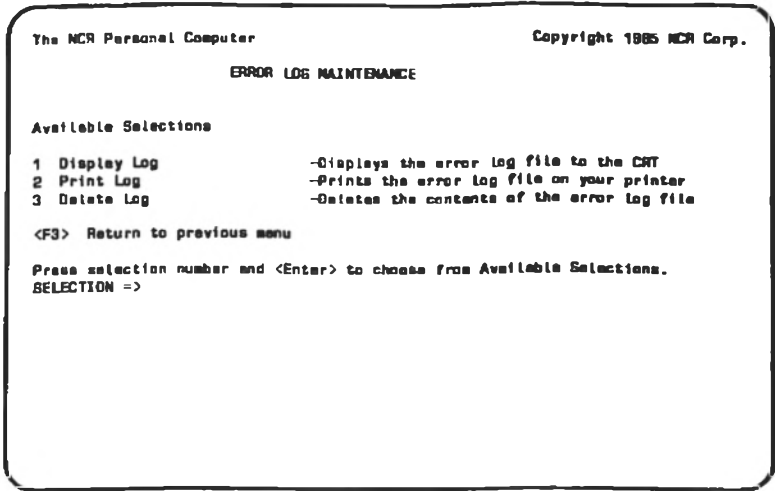

Figure 4-35 Error Log Maintenance Screen

### 1 Display Log

This selection causes the system to display the error log file to your display. The format of an error message is:

```

MEMORY          01-31-85   14:34:56
RANDOM ACCESS MEMORY (RAM) ADDRESS ERROR

```

### 2 Print Log

This selection causes the system to print the error log file to your printer. This gives you a hard copy of the errors logged during a diagnostics run. You may now want to choose selection 3 to clear your error log file. It is not necessary to delete the file, since the system logs in the time and date but you may need the data space on the diskette.

### 3 Delete Log

You delete the contents of the error log file when you make this selection. It's always a good idea to keep a record of any data from the error log, so print the contents of the log before you make this selection.

### Add/Delete Test Modules

The Add/Delete Test Modules screen is displayed when you press the **F9** key in the Main Menu (see Figure 4-36). Here you have the ability to

integrate test modules from new optional kits into your existing diagnostic system.

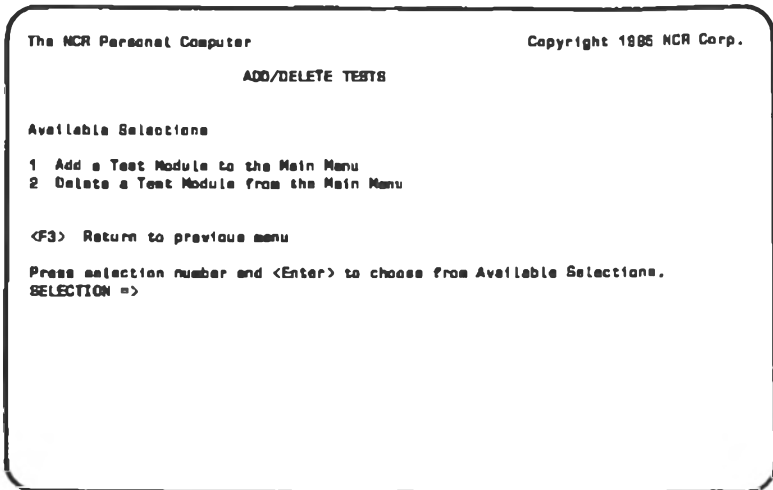

Figure 4-36 Add/Delete Tests Screen

### Selection 1 Add a Test Module to the Main Menu

The system displays a screen (see Figure 4-37) with blanks. You must fill in the blanks with the required information. You have the option of defining the selection number for the module you are installing. If you define the selection number, the other test numbers are automatically adjusted.

The file name on the diagnostics diskette of the module you are installing is the exact file name recognized by DOS. After you enter all the required information, another screen listing the new, updated, Main Menu is displayed. You may add another test by answering the prompt with a **Y** and pressing **ENTER**. If you want to return to the Add/Delete Menu screen, press **N**.

|   |                          |
|---|--------------------------|
| The NCR Personal Computer   | Copyright 1985 NCR Corp. |
| ADD TESTS   |                          |
| Selection number on Main Menu: <input type="text"/> (others will be adjusted) |                          |
| Name to appear on menu selection: <input type="text"/>                        |                          |
| Short description of selection: <input type="text"/>                          |                          |
| File name of Test Module: <input type="text"/>                                |                          |
| <ESC> to CANCEL Test Module Addition  |                          |

Figure 4-37 Add a Test Module Screen

### Selection 2 Delete a Test Module from the Main Menu

The system displays the *Delete Tests Menu Screen* (see Figure 4-38). At this screen you can **Pg Up** and **Pg Dn** to page through the available selections just as in the Main Menu. After you enter the number of the selected test module you want to delete, a prompt appears and asks you to verify the delete selection. It also asks you if you are sure of this selection.

If you press **Y**, the module test is deleted. A new Delete module screen is displayed with the updated modules.

If you press **N**, the module test is not deleted and the old Delete tests menu screen is displayed.

You may return to the Add/Delete Test Menu screen by pressing the **ESC** key.

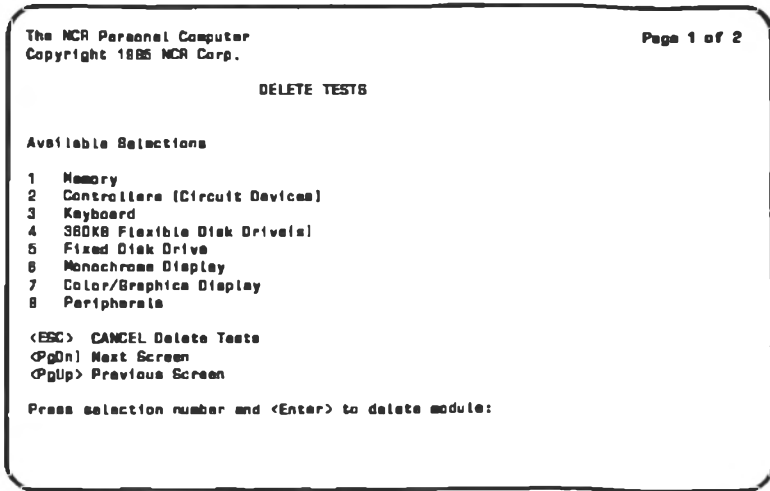

Figure 4-38 Delete a Test Module Screen

## Run All Tests

You can press the **F7** key to run all the tests once, or you can press the **F8** key to run all the tests continuously until you press the **F4** key to stop the tests. When you make the **F7** selection, the system runs all the tests in a sequential order. The actual tests within the module are also executed sequentially. You are not required to interact with the computer in the continuous mode.







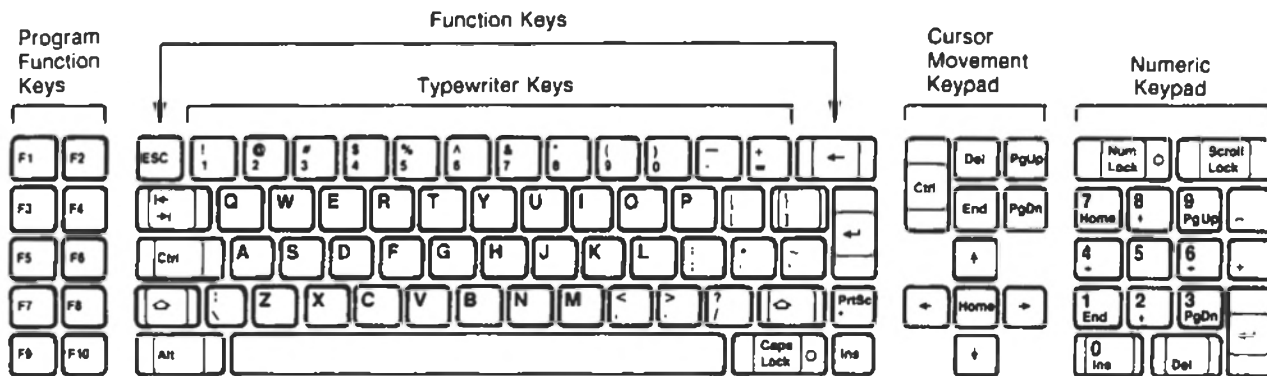



## Exit from Diagnostics













You can press the **F10** key to exit from the DIAGNOSTICS program. The DOS prompt is displayed.

# *Keyboard Functions*



KEYBOARD CHART

| KEY FUNCTION CHART   |  |   |
|--|--|---|
| Key/Name   | Function   | Notes   |
| <br>Escape        | Used to escape from the structure of a program                                       |   |
| <br>Tab           | Used to move cursor to tab positions   |   |
| <br>Control       | Used to access alternate functions of keys   |   |
| <br>Shift         | Used to access "shifted" functions of keys   |   |
| <br>Alternate     | Used to access alternate functions of keys   |   |
| <br>Backspace     | Moves cursor one character to the left with each stroke                              | Erases characters at cursor position.   |
| <br>Return        | Moves cursor from end of one line to beginning of next. Also used to enter commands. | Referred to as Enter key, or Carriage Return, <CR>  |
| <br>Capital Lock | Locks alpha keyboard in uppercase mode   | Does not access shifted modes of keys, caps lock only causes alpha keys to print uppercase. |
| <br>Num Lock    | Activates and deactivates numeric keypad. Functions as a toggle switch.              | Light on key comes on when numeric keypad is active.  |
| <br>Home        | Returns cursor to top left of screen   | 7 key is activated when number lock is toggled.   |
| <br>Cursor Left | Moves cursor one character to the left with each stroke; does not delete characters. | 4 key is activated when number lock is toggled.   |

| Key/Name  | Function  | Notes   |
|---|---|---|
| <br>End            | Moves cursor to last character in the line                      | 1 key is activated when number lock is toggled.                                 |
| <br>Cursor Up      | Moves cursor up one line each stroke                            | 8 key is activated when number lock is toggled.                                 |
| <br>Cursor Down    | Moves cursor down one line each stroke (Inactive in NCR-DOS)    | 2 key is activated when number lock is toggled.                                 |
| <br>Insert         | Activates and deactivates "Insert Mode".                        | 0 key is activated when number lock is toggled.                                 |
| <br>Page Up        | Displays previous page of text or program (Inactive in NCR-DOS) | 9 key is activated when number lock is toggled                                  |
| <br>Cursor Right   | Moves cursor one character to the right with each stroke.       | Deletes characters it passes<br>6 key is activated when number lock is toggled. |
| <br>Page Down      | Displays next page of text or program.                          | 3 key is activated when number lock is toggled.                                 |
| <br>Delete         | Used to delete portions of text                                 | Decimal point is activated when number lock is toggled.                         |
| <br>Scroll Lock    | Freezes scrolling information on CRT                            | When pressed with Ctrl, is Break key.   |
| <br>Minus        | Used to indicate negative values of numbers.                    |   |
| <br>Plus         | Used to indicate positive values of numbers.                    |   |
| <br>Print Screen | Prints asterisk.  | When pressed with shift + information on screen is sent to printer.             |



## Technical Data

| NCR PC Model 4i — Technical Specifications |  |                           |              |
|--|--|---------------------------|--------------|
| <b>SIZE</b>                                | <b>Height</b>  | <b>Width</b>              | <b>Depth</b> |
| Computer:                                  | 14 1/2"  | 18"                       | 16"          |
| Keyboard:                                  | 1.75 inches  | 20.88 inches              | 7.88 inches  |
| <b>WEIGHT</b>                              |  |                           |              |
| Computer:                                  | 50 lbs.  |                           |              |
| Keyboard:                                  | 4 1/2 lbs.   |                           |              |
| <b>Nominal Voltage:</b>                    | 120 volts AC   | Range 104 to 127 volts AC |              |
| <b>Frequency:</b>                          | 59/60.6 Hz   |                           |              |
| <b>Power</b>                               | 116 watts (maximum)<br>2.5 amp (maximum)   |                           |              |
| <b>Cable Length</b>                        | Power 3 m.<br>Keyboard 1 m. coiled cord (extendable)<br>Parallel Printer 2 m.<br>RS 232 Serial Printer 2 m.<br>RS 232 Communication Cable 2 m. |                           |              |
| <b>ENVIRONMENT</b>                         | <b>Operating</b>   | <b>Power Off</b>          |              |
| Temperature                                | 15.6° to 32° C   | 10° to 43° C              |              |
|  | 60° to 90° F   | 50° to 110° F             |              |
| Humidity                                   | 8% to 80%  | 8% to 80%                 |              |
| <b>Product Safety</b>                      | UL 478 UL listing mark used  |                           |              |
| <b>Electromagnetic Compatibility:</b>      | FCC Class B Certified<br>VDE Certified   |                           |              |

| <b>Main Processor Board</b> |   |
|-----------------------------|---|
| Central Processing Unit     | 8088-2 Microprocessor   |
| RAM/Expansion RAM           | 256 KB (standard); up to 640 KB total optional                                  |
| EPROM                       | 16 K byte BIOS included   |
| Ports                       | 1 parallel printer port (Centronics)<br>1 RS232C serial port<br>1 keyboard port |
| Expansion Slots             | 8 slots, third party compatible   |

| <b>Keyboard</b>       |                               |
|-----------------------|-------------------------------|
| Data Transfer Mode    | bidirectional, serial         |
| Number of Conductors  | 4-wire shielded, coiled cable |
| KEY ARRANGEMENT       |                               |
| Number of Keys        | 95                            |
| Special Function Keys | 10 program function keys      |
| Numeric Keypad Area   | 16 keys                       |
| Cursor Control        | 5 cursor positioning keys     |

| Expansion Slot Connections |               |    |             |
|----------------------------|---------------|----|-------------|
| A                          | Function      | B  | Function    |
| 1                          | -I/O CHECK    | 1  | Ground      |
| 2                          | +DATA 7       | 2  | +RESET I/O  |
| 3                          | +DATA 6       | 3  | +5V         |
| 4                          | +DATA 5       | 4  | +IRQ2       |
| 5                          | +DATA 4       | 5  | -5V         |
| 6                          | +DATA 3       | 6  | +DRQ2       |
| 7                          | +DATA 2       | 7  | -12V        |
| 8                          | +DATA 1       | 8  | -HRQ I/O CH |
| 9                          | +DATA 0       | 9  | +12V        |
| 10                         | +I/O CHAN RDY | 10 | Ground      |
| 11                         | +BAEN         | 11 | -MEMW       |
| 12                         | +ADDRESS 19   | 12 | -MEMR       |
| 13                         | +ADDRESS 18   | 13 | -IOW        |
| 14                         | +ADDRESS 17   | 14 | -IOR        |
| 15                         | +ADDRESS 16   | 15 | -DACK3      |
| 16                         | +ADDRESS 15   | 16 | +DRQ3       |
| 17                         | +ADDRESS 14   | 17 | -DACK1      |
| 18                         | +ADDRESS 13   | 18 | +DRQ1       |
| 19                         | +ADDRESS 12   | 19 | -BDACK0     |
| 20                         | +ADDRESS 11   | 20 | +BCLK       |
| 21                         | +ADDRESS 10   | 21 | +IRQ7       |
| 22                         | +ADDRESS 9    | 22 | +IRQ6       |
| 23                         | +ADDRESS 8    | 23 | +IRQ5       |
| 24                         | +ADDRESS 7    | 24 | +IRQ4       |
| 25                         | +ADDRESS 6    | 25 | +IRQ3       |
| 26                         | +ADDRESS 5    | 26 | -DACK2      |
| 27                         | +ADDRESS 4    | 27 | +T/C        |
| 28                         | +ADDRESS 3    | 28 | +ALE        |
| 29                         | +ADDRESS 2    | 29 | +5V         |
| 30                         | +ADDRESS 1    | 30 | +OSC        |
| 31                         | +ADDRESS 0    | 31 | Ground      |

| <b>BIOS Connection</b> |                                  |
|------------------------|----------------------------------|
| <b>Interrupt</b>       | <b>Function</b>                  |
| 0                      | Divide by zero                   |
| 1                      | Single step                      |
| 2                      | Non-maskable interrupt           |
| 3                      | Break point instruction          |
| 4                      | Overflow                         |
| 5                      | Print screen                     |
| 6                      | Reserved                         |
| 7                      | Reserved                         |
| 8                      | Timer, 18.2 ticks per second     |
| 9                      | Keyboard                         |
| A                      | Reserved                         |
| B                      | Reserved for communications      |
| C                      | Reserved for communications      |
| D                      | Fixed disk (XT)                  |
| E                      | Diskette                         |
| F                      | Reserved for printer             |
| 10                     | Video I/O                        |
| 11                     | Equipment check (configuration)  |
| 12                     | Memory check (configuration)     |
| 13                     | Diskette I/O                     |
| 14                     | RS-232 I/O                       |
| 15                     | Cassette I/O                     |
| 16                     | Keyboard I/O                     |
| 17                     | Printer I/O                      |
| 18                     | ROM BASIC                        |
| 19                     | Bootstrap                        |
| 1A                     | Time of day                      |
| 1B                     | Crtl-Break control               |
| 1C                     | Timer control                    |
| 1D                     | Video initialization             |
| 1E                     | Disk parameter table pointer     |
| 1F                     | Graphics character table pointer |

| <b>Hardware Interrupt Levels</b> |   |
|----------------------------------|---|
| 0                                | Timer Channel 0                         |
| 1                                | Keyboard                                |
| 2                                | Expansion Slots                         |
| 3                                | Expansion Slots                         |
| 4                                | Serial Asynchronous Communications Port |
| 5                                | Expansion Slots (Fixed Disk)            |
| 6                                | Flexible Diskette Drive Controller      |
| 7                                | Parallel (Printer) Port                 |

| Keyboard |           |  |
|----------|-----------|--|
| Pin      | Signal    | Direction                                |
| 1        | + Clock   | Bidirectional<br>Bidirectional<br>Output |
| 2        | + Data    |  |
| 3        | - Reset   |  |
| 4        | Ground    |  |
| 5        | + 5 Volts |  |

| Serial Interface RS232C |                     |
|-------------------------|---------------------|
| Pin<br>D-SUB,J2,J5      | Signal              |
| 2,19,3                  | Transmit Data       |
| 3,20,5                  | Receive Data        |
| 4,21,7                  | Request To Send     |
| 5,22,9                  | Clear To Send       |
| 6,26,14                 | Data Set Ready      |
| 7,25,13                 | Logic Ground        |
| 8,27,15                 | Signal Detector     |
| 20,26,14                | Data Terminal Ready |
| 22,29,18                | Ring Indicator      |

| Flexible Diskette Connector |                  |
|-----------------------------|------------------|
| Pin                         | Signal           |
| 1                           | Ground           |
| 2                           | —                |
| 3                           | Ground           |
| 4                           | In Use           |
| 5                           | Ground           |
| 6                           | Drive Select 3   |
| 7                           | Ground           |
| 8                           | Index/Selector   |
| 9                           | Ground           |
| 10                          | Drive Select 0   |
| 11                          | Ground           |
| 12                          | Drive Select 1   |
| 13                          | Ground           |
| 14                          | Drive Select 2   |
| 15                          | Ground           |
| 16                          | Motor On         |
| 17                          | Ground           |
| 18                          | Direction Select |
| 19                          | Ground           |
| 20                          | Step             |
| 21                          | Ground           |
| 22                          | Write Data       |
| 23                          | Ground           |
| 24                          | Write Gate       |
| 25                          | Ground           |
| 26                          | Track 00         |
| 27                          | Ground           |
| 28                          | Write Protect    |
| 29                          | Ground           |
| 30                          | Read Data        |
| 31                          | Ground           |
| 32                          | Side One Select  |
| 33                          | Ground           |
| 34                          | Ready            |

| Parallel Interface |              |           |
|--------------------|--------------|-----------|
| Pin<br>D-SUB,J2,J6 | Signal       | Direction |
| 1, 18, 1           | - STROBE     | Output    |
| 2, 16, 3           | + DATA0      | Output    |
| 3, 14, 5           | + DATA1      | Output    |
| 4, 12, 7           | + DATA2      | Output    |
| 5, 10, 9           | + DATA3      | Output    |
| 6, 9, 11           | + DATA4      | Output    |
| 7, 8, 13           | + DATA5      | Output    |
| 8, 7, 15           | + DATA6      | Output    |
| 9, 6, 17           | + DATA7      | Output    |
| 10, 5, 19          | - ACK        | Input     |
| 11, 4, 21          | + BUSY       | Input     |
| 12, 3, 23          | + PE         | Input     |
| 13, 1, 25          | + SLCT       | Input     |
| 14, 17, 2          | + AUTO FDXT  | Output    |
| 15, 15, 4          | - ERROR      | Input     |
| 16, 13, 6          | - INIT       | Output    |
| 17, 11, 8          | - SLCT IN    | Output    |
| 18-25              | Ground D-SUB |           |
| 2                  | Ground J2    |           |
| 10, 12, 14, }      |              |           |
| 16, 18, 20, }      | Ground J6    |           |
| 22, 24 }           |              |           |

# System Switch Settings

## System Switch Settings

| SW1  |                        |                        |           |           |                  |                  |
|--|------------------------|------------------------|-----------|-----------|------------------|------------------|
| Function   | 1                      | 2                      | 3         | 4         | 5                | 6                |
| MPB Memory<br>256 K to 640 K   |                        |                        | OFF       | OFF       |                  |                  |
| Monochrome<br>Graphics (40x25)<br>Graphics (80x25)   |                        |                        |           |           | OFF<br>OFF<br>ON | OFF<br>ON<br>OFF |
| Numeric Coprocessor Installed<br>Numeric Coprocessor Not Installed   |                        | OFF<br>ON              |           |           |                  |                  |
| SWA  |                        |                        |           |           |                  |                  |
| Function   | 1                      | 2                      | 3         | 4         | 5                | 6                |
| System Board Memory<br>64Kx1 64Kx1 64Kx1 64Kx1<br>256Kx1 0 0 0<br>64Kx1 64Kx1 256Kx1 256Kx1<br>256Kx1 256Kx1 64Kx1 64Kx1 | OFF<br>OFF<br>ON<br>ON | OFF<br>ON<br>OFF<br>ON |           |           |                  |                  |
| Serial Port Enabled<br>Serial Port Disabled  |                        |                        | ON<br>OFF |           |                  |                  |
| Parallel Port Enabled<br>Parallel Port Disabled  |                        |                        |           | ON<br>OFF |                  |                  |

| Switch No. |     |     |    | Memory Size | Explanation            |
|------------|-----|-----|----|-------------|------------------------|
| 1          | 2   | 3   | 4  |             |                        |
| ON         | ON  | ON  | ON | 64 KB       | Setting as delivered   |
| OFF        | ON  | ON  | ON | 128 KB      | First 64 KB expansion  |
| ON         | OFF | ON  | ON | 192 KB      | Second 64 KB expansion |
| OFF        | OFF | ON  | ON | 256 KB      | Third 64 KB expansion  |
| ON         | ON  | OFF | ON | 320 KB      | Fourth 64 KB expansion |
| OFF        | ON  | OFF | ON | 384 KB      | Fifth 64 KB expansion  |

Expansion Memory Board Switch Settings

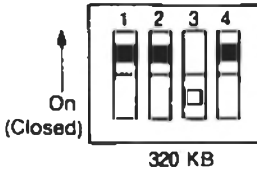
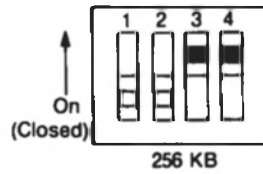
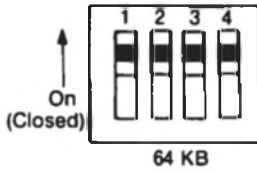

Fixed Disk Controller Board





SW1

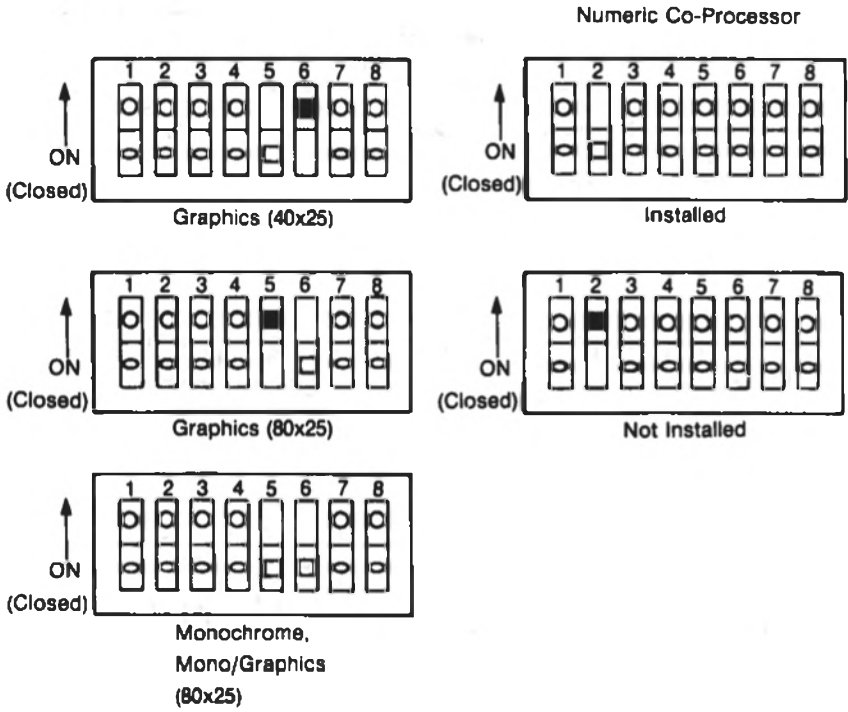

SWB

| MPB Memory |        |        |        |        |       |       |
|------------|--------|--------|--------|--------|-------|-------|
|            | Bank 0 | Bank 1 | Bank 2 | Bank 3 | No. 1 | No. 2 |
| A          | 64 K   | 64 K   | 64 K   | 64 K   | OFF   | OFF   |
| B          | 256 K  | 0      | 0      | 0      | OFF   | ON    |
| C          | 256 K  | 256 K  | 64 K   | 64 K   | ON    | ON    |
| D          | 64 K   | 64 K   | 256 K  | 256 K  | ON    | OFF   |

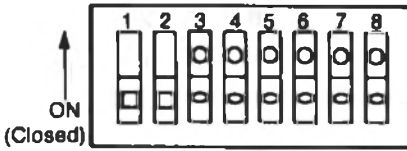

A

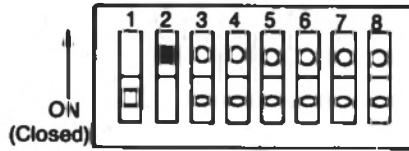

B

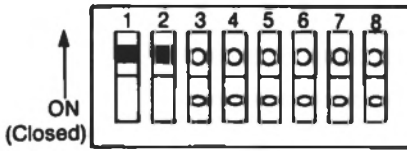

C

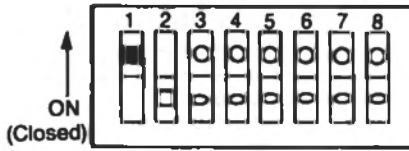

D

Serial Port

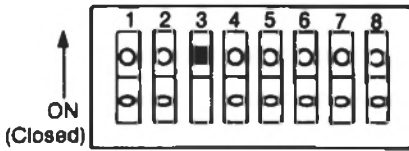

Enabled

Parallel Port

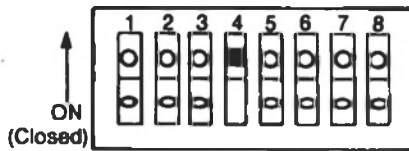

Enabled

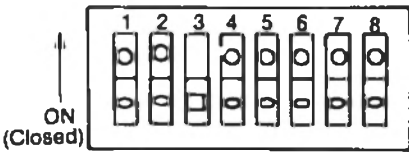

Disabled

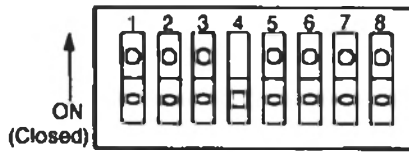

Disabled

# Glossary

## A

### **ABORTED**

Ended abnormally before completion, such as a function that is interrupted before completion.

### **ACOUSTIC COUPLER**

A modem that converts the data to be transmitted into a sequence of different tones; sent via a conventional telephone handset to a receiving modem; converts them back to a stream of binary digits.

### **ACRONYM**

A word formed from the first letter or letters of the words in a name, term, or phrase.

### **ADAPTER**

A connector that has a plug for one type of cable or device and a socket for another type. An adapter allows parts of a computer which ordinarily don't fit together to be connected.

### **ADDRESS**

Data is contained in the devices which make up your computer's internal and external memory and the registers in its CPU. Each accessible location within a device is assigned a number, which is known as an "address". In internal memory, the address is a specific byte number. In external memory, the address is a unit number (for example, drive A) and, for disk or diskette drives, the address may include a track number and a sector number. Your computer is able to locate data using these addresses.

### **APPLICATION PROGRAM**

A program that you use on your computer to perform a specific job, such as budgeting or word processing.

## **ASCII**

American National Standard Code for Information Interchange. The standard code, using a coded character set consisting of 7-bit coded characters (8 bits including parity check), used for information interchange among data processing systems, data communication systems, and associated equipment. The ASCII set consists of control characters and graphic characters.

## **ASSEMBLE**

To prepare an object language program from a symbolic language program by substituting machine operation codes for symbolic operation codes and absolute addresses for symbolic addresses.

## **ASSEMBLER**

A computer program that operates on symbolic input data to produce machine instructions. An assembler generally translates input symbolic codes into machine instructions, item for item, and produces, as an output, the same number of instructions or constants that were defined in the input symbolic codes.

## **ASYNCHRONOUS**

Characterizing different time intervals between events or occurrences.

## **ASYNCHRONOUS DATA TRANSMISSION**

A format for data transmitted across telephone lines in which each character is "framed" by a start bit and a stop bit. Thus, when transmitted asynchronously, each character is 10 bits in length: seven information bits, one parity bit, one start bit, and one stop bit.

## **B**

### **BACK UP, verb**

The process of duplicating data from one location to another (i.e., diskette to diskette, or fixed disk to diskette) to prevent total information loss should the original record be lost or damaged.

### **BACKUP, noun**

A copy of a file or disk/diskette.

### **BACK-UP, adjective**

A system that performs the process of backing up data or files.

**BASIC**

1. Acronym for the programming language Beginner's All-purpose Symbolic Instruction Code. BASIC uses common English words and is relatively easy to use.
2. The computer program which translates statements made in BASIC programming language into instructions to the computer.

**BINARY CODE**

A system of numbering which uses only two values, zero and one. For example, the ASCII letter D is represented as 01000100.

**BINARY DIGIT (bit)**

Either of the characters 0 or 1, abbreviated as bit.

**BLOCK**

A physical unit of data that can be conveniently stored by a computer on an input or output device. The term is synonymous with physical record. The block is normally composed of one or more logical records or a portion of a logical record.

**BPI**

Abbreviation for bits per inch. The standard measure for the density of data recording on disks/diskettes/tapes.

**BPS**

An abbreviation for bits per second. In serial transmission, the instantaneous bit speed with which a device or channel transmits a character.

**BYTE**

A sequence of adjacent bits operated upon as a unit. The smallest addressable memory element; usually represents one character. In your computer, each byte consists of eight bits plus one parity bit.

**C****CARTRIDGE**

A container with a reel of magnetic tape for the storage of data and a takeup reel for transfer of the tape within the cartridge by means of a capstan drive system.

### **CATHODE RAY TUBE (CRT)**

An electronic vacuum tube with a screen, such as a television picture tube, upon which information may be displayed.

### **CENTRAL PROCESSING UNIT (CPU)**

The central processor or the computer system contains the internal memory unit (memory), the arithmetic logic unit (ALU), and the input/output control unit (I/O Control).

### **COBOL**

An acronym for Common Business Oriented Language — a higher level language developed for business data-processing applications.

### **CODING**

(1) The writing of a list of instructions which will cause a computer to perform specified operations. (2) An ordered list or lists of the successive instructions which will cause a computer to perform a particular process.

### **COMMAND**

An instruction which tells the operating system what you want to do.

### **COMMUNICATION ADAPTER**

A hardware component that is hardwired into the telephone line which prepares data for transmission through a telephone line.

### **COMPILER**

A computer program that operates on symbolic input data to produce machine instructions. A compiler is more powerful than an assembler. It is able to replace certain input items with a series of instructions. The program which results from compiling is a translated and expanded version of the original program.

### **COMPONENT**

A functional part of an operating system, i.e., your keyboard.

### **COMPRESSION**

The elimination of blank spaces on the magnetic tape or disk by placing data files immediately adjacent to each other.

**COMPUTER**

A device capable of accepting data in the form of facts and figures, applying prescribed processes to the data and supplying the results of these processes as meaningful information. This device usually consists of input and output devices, storage, arithmetic and logic units, and a control unit. Usually, an automatic, stored-program machine is implied.

**COMPUTER-ASSISTED INSTRUCTION (CAI)**

A data processing application in which a computing system assists in the instruction of students. The application usually involves a dialog between the student and a computer program which informs the student of mistakes as they are made.

**COMPUTER SYSTEM**

The physical equipment and instructions; i.e., hardware and software, used as a unit to process data. It includes the central processing unit (CPU), its operating system, and peripheral equipment and programs under its control.

**CONVERSATIONAL MODE**

A mode of operation of a data processing system in which a sequence of alternating entries and responses between a user and the system takes place in a manner similar to a dialog between two persons.

**CPS**

Abbreviation for characters per second. It is a standard way of measuring the printing speed of a printer.

**CPU**

See central processing unit.

**CRT**

See cathode ray tube.

**CURSOR**

A moving, sliding, or blinking symbol on a CRT which indicates where the next character will appear.

**CYLINDER**

The tracks of a disk storage device that can be accessed without repositioning the access mechanism.

**D****DATA**

Any information — letters, numbers, symbols — which is input to, or output from, the computer for storage or manipulation.

**DATA BASE**

A collection of data fundamental to an enterprise.

**DEBUG**

To detect, to trace, and to eliminate mistakes in computer programs or in other software.

**DEFAULT**

An alternative value, attribute, or option that is automatically selected by the computer program when none has been specified.

**DESTINATION FILE**

A file designated to receive the information which is output from a computer run.

**DIAGNOSTICS**

Procedures used to identify and isolate problems within the computer or its peripherals.

**DIRECTORY**

A list of file names kept on each disk or diskette.

**DISKETTE**

A thin, flat piece of flexible plastic which looks like a phonograph record. It is coated with magnetic material and is encased in a protective paper jacket. Data is recorded and stored on a diskette. Flexible Disk, Floppy Disk, Disk, Flexible Diskette, Floppy Diskette, Floppy, Mini Disk are all common names used to refer to a removable diskette.

**DISKETTE ENVELOPE**

A heavy paper envelope in which diskettes are stored except when in use.

**E****EBCDIC**

An acronym for Extended Binary Coded Decimal Interchange Code. A coded character set consisting of 8-bit coded characters.



**EDIT**

To prepare data for a later operation. Editing may include the rearrangement or the addition of data, the deletion of unwanted data, format control, code conversion, and the application of standard processes such as zero suppression.

**ELECTRONICS**

Pertaining to the application of that branch of science which deals with the motion, emission and behavior of currents of free electrons, especially in vacuum, gas or phototubes and special conductors or semiconductors. Contrasted with "electric" which pertains to the flow of large currents in wires only.

**EPROM**

An acronym for Erasable PROM. One of the latest types of monolithic memory. It can be programmed in the field by the user, and it can also be erased and reprogrammed with different information. Once it has been programmed the EPROM memory acts just the same as ROM.

**ERASE**

To remove data from a data medium, leaving the medium available for recording new data.

**EXTENSION**

A one-, two-, or three-letter addition to a filename generally used to identify what type of data file it is.

**F****FIELD**

A unit of data within a record or area. A logical grouping of contiguous characters.

**FILE**

A set of related records grouped and identified together; the records in a file may be sequenced according to a key contained in each record.

**FILENAME**

The name applied to a data file to identify it so that the computer can locate it and recall it from a storage device.

**FILE-SELECTABLE**

The ability of a computer to select data from a storage device by the filename or to transfer data to storage by single filename.

**FIXED DISK**

A thin, flat, circular piece of rigid plastic or aluminum on which data and information is stored. Hard disks are able to store much more data than flexible diskettes.

**FORMATTED DISKETTE**

A diskette on which track and sector control information has been written by a particular computer system, i.e., NCR-DOS, but which contains no data.

**FORTRAN**

An acronym for FORMula TRANslator. A high level programming language used to perform mathematical, scientific, and engineering computations.

**FUNCTION**

Any activity of the computer directed by the software, such as loading a file into memory, saving a file onto a disk, or performing a series of calculations.

**G**

**GLITCH**

A sudden, often unexplained, electronic occurrence which causes problems in an electronic device.

**GRAPHICS**

Facilities to provide computer output in the form of displays, drawings, and pictures.

**H**

**HARD COPY**

A printed copy of machine output in readable form, i.e., reports, listings, documents, summaries.

**HARD DISK**

See fixed disk.

**HARDWARE**

Physical equipment used in data processing. Contrast with software.

**HEAD**

A device that reads, records, or erases data on a storage medium, e.g., a small electromagnet used to read, write, or erase data on a magnetic disk.

**HEXADECIMAL DIGIT**

A whole number in the hexadecimal numeral system (based on a radix of 16). A hexadecimal digit can be expressed in any one of sixteen different characters: 0,1,2,3,4,5,6,7,8,9,a,b,c,d,e,f.

**HOUSEKEEPING**

Computer operations that do not directly contribute toward the desired results; in general, initialization, set-up, diagnostics.

|

**ILLEGAL CHARACTER**

A character or combination of bits which is not accepted as a valid or known representation by the computer.

**INDICATOR**

A device which registers a condition in the computer.

**INITIALIZE**

To set counters, switches, and addresses to zero or other starting values at the beginning of, or at prescribed points in, a computer routine.

**I/O**

Abbreviation for "input and output". Input is the data received by the CPU from devices connected to it. Output is that which is sent from the CPU to those devices.

**INPUT**

The introduction of data from an external storage medium into a computer's internal storage unit.

**INSTRUCTION**

A group of characters, bytes, or bits that defines an operation to be performed by the computer.

## **INTERFACE**

A common boundary between two or more electronic devices or software programs which enables them to transfer information.

## **INTERRUPT**

A suspension of a process, such as the execution of a computer program, caused by an event external to that process, and performed in such a way that the process can be resumed.

## **K**

### **KEY**

(1) The field or fields which identify a record. (2) The field which determines the position of a record in a sorted sequence. (3) A lever on a manually operated machine, such as a typewriter.

### **KILOBYTE**

A kilobyte is 1024 bytes. It is commonly abbreviated as K, and used as a suffix when describing memory size in computers. Thus, 24K really means a  $24 \times 1024 = 24,576$  byte memory system.

## **L**

### **LANGUAGE**

A set of characters, conventions, and rules, that is used for conveying information. The three aspects of language are pragmatics, semantics, and syntax.

### **LED**

An acronym for Light Emitting Diode, a commonly used alphanumeric display unit which glows when supplied with a specified voltage.

### **LOAD**

To enter data into storage or working registers of the computer.

### **LOG**

A record of the operations of data processing equipment, listing each job or run, the time it required, operator actions, and other pertinent data.

**LOGGING-ON**

Giving the computer (particularly if it is a part of a larger system) information such as your name and a password in order to be able to use the system.

**LOOP**

A sequence of instructions in a program that can be executed repetitively until certain specified conditions are satisfied.

**M****MACHINE INSTRUCTION**

An instruction that a computer can directly recognize and execute.

**MACHINE LANGUAGE**

The basic language of a computer.

**MACRO INSTRUCTION**

(1) A source language instruction that is equivalent to a specified number of machine language instructions. (2) A machine language instruction that is composed of several micro instructions.

**MEMORY**

The storage facilities of the computer, capable of storing vast amounts of data.

**MENU**

Options listed in a display image that can be selected by the user of the display device.

**MICRO INSTRUCTION**

A low level instruction used to obtain a macro, or machine language instruction.

**MIRROR-IMAGE**

Exact copy of a data storage system such as a hard disk with files arranged in exactly the same sequence, including any blank spaces.

**MODEM**

Modulator-Demodulator. A device which converts (modulates) serialized digital signals (usually output from a communications

adapter) to acoustic signals for transmission over a telephone line and converts (demodulates) incoming acoustic signals to serialized digital signals.

## O

### **OPERATING SYSTEM**

An organized collection of software that controls the overall operations of a computer. The operating system does many basic operations which were performed by hardware in older machines, or which are common to many programs. It is available to the computer at all times either being held in internal storage or on an auxiliary storage device.

### **OPERATION**

A defined action. The action specified by a single computer instruction or high level language statement.

### **OPERATION CODE**

The instruction code used to specify the operations a computer is to perform.

### **OUTPUT**

(1) Data transferred from a computer's internal storage unit to some storage or output device. (2) The final result of data processing; data that has been processed by the computer.

## P

### **PARALLEL TRANSMISSION**

In data communications, a method of data transfer in which all bits of a character are sent simultaneously.

### **PARAMETER**

An arbitrary constant. A variable in an algebraic expression that temporarily assumes the properties of a constant.

### **PARITY**

A method used by most of the computer industry to determine if hardware has correctly sent and received data characters. If hardware checks for even parity, it considers valid all characters moved between units, memory registers, or memories whose total number of ON bits is even. If hardware checks for odd parity, it

considers valid all characters moved between units, memory registers, or memories whose total number of ON bits is odd.

**PARITY BIT**

The extra bit that computer hardware adds to a character or group of characters prior to moving the character between units, memory registers, or memories. Hardware sets the bit either OFF or ON to develop either an odd or even number of ON bits in the character. When this character is received, hardware checks the parity to determine if the data was correctly received or if a parity error exists.

**PARITY CHECKING**

Automatic error detection by using checking bits along with the numerical bits.

**PASCAL, BLAISE**

(1623-1662) A French mathematician who built the first desk-calculator type of adding machine in 1642. This device represented the numbers from 0 to 9 with teeth on gears. The machine could perform addition and subtraction.

**PASCAL**

A high-level, procedure-oriented programming language named for Blaise Pascal.

**PASSWORD**

A unique string of characters that a program, computer operator, or user must supply to meet security requirements before gaining access to data.

**PERIPHERAL**

A device which is separate from the computer but which works in conjunction with it, such as a printer, a keyboard, a disk drive, etc.

**PHYSICAL RECORD**

The unit of data for input or output; e.g., a punched card, a tape block, a record on a disk.

**PIXEL**

A picture element.

## **PL/1**

A high level programming language designed to process both scientific and business applications. The PL/1 language contains many of the best features of FORTRAN, COBOL, ALGOL and other languages as well as a number of facilities not available in previous languages.

## **PROCESSOR**

A device or system capable of performing operations upon data; e.g., CPU (hardware) or compiler (software). A compiler is sometimes referred to as a language processor.

## **PROGRAM**

(1) A set of sequenced instructions to cause a computer to perform particular operations. (2) A plan to achieve a problem solution. (3) To design, write, and test one or more routines. (4) Loosely, a routine.

## **PROGRAMMING**

The process of translating a problem from its physical environment to a language that a computer can understand and obey. The process of planning the procedure for solving a problem. This may involve among other things the analysis of the problem, preparation of a flowchart, coding of the problem, establishing input/output formats, establishing testing and checkout procedures, allocation of storage, preparation of documentation, and supervision of the running of the program on a computer.

## **PROM**

An acronym for Programmable Read Only Memory. A memory that can be programmed by electrical pulses. Once programmed, it is read only. The PROM chips can be purchased blank and then be programmed by using a special machine. Once programmed, this memory behaves the same as the ROM. That is, it can be read as many times as desired but cannot be written.

## **R**

## **RAM**

Random Access Memory. The type of internal memory of a computer in which data can be written to, read from, erased, or stored in any order. RAM is maintained by electrical current and makes up much of the internal memory.



**RESET**

(1) To return computer components to a specified static state. (2)  
To place a binary cell into the zero state.

**RESPONSE TIME**

The time it takes the computer system to react to a given input. It is the interval between an event and the system's response to the event.

**RESTART**

To reestablish the execution of a routine.

**RESTORE**

To recover data from a storage device such as a tape cartridge and transfer it back to the disk from where it was originally copied.

**RETENSION**

To adjust the tension again on the tape in a cartridge so that it is uniform in tension throughout the reel.

**ROM**

An acronym for Read Only Memory. Nonerasable, permanently programmed memory usually used to store monitors, I/O drivers, interpreters, or special application functions. It is not possible to write into ROM memory.

**ROUTINE**

A set of machine instructions for carrying out a specific processing operation. Sometimes used as a synonym for program.

**RUN TIME**

The time during which the data are fetched by the control unit and the actual processing is performed in the arithmetic unit.

**S****SAVE TO TAPE**

Transfer data from disk or other memory device to tape.

**SCREEN**

The display surface of a CRT device.

## **SCROLL**

To roll lines up or down a CRT screen to review text or information. Most screens display only 25 lines at a time, so scrolling is useful in viewing large files of information.

## **SECTOR**

One of the peripheral elements into which each track of a disk surface is divided. Disks are usually formatted into 8 or 9 sectors.

## **SOFTWARE**

The non-physical portion of your system. Any kind of program within the electrical circuits of a computer is software.

## **SOURCE DOCUMENT**

An original document from which basic data are extracted; e.g., invoice, sales slip, inventory tag.

## **SPECIAL CHARACTER**

A graphic character that is not a letter, a digit, nor a blank; e.g., plus sign, equal sign, asterisk, dollar sign, comma, and period.

## **START/STOP**

A mode of operation of a tape drive in which the data are transferred in blocks during which the tape runs and then stops while the computer reads more data for transfer.

## **STATEMENT**

In programming, an expression or generalized instruction in a source language.

## **STORAGE**

Descriptive of a device or medium that can accept data, hold them, and deliver them on demand at a later time. The term is preferred to memory.

## **STORAGE CAPACITY**

The number of items of data which a storage device is capable of containing. Frequently defined in terms of computer words, bytes, or characters.

## **SYNCHRONOUS DATA TRANSMISSION**

A transmission mode in which regularly timed clock pulses are used to provide synchronization between the transmitting and

receiving devices on a communication line. Synchronous transmission reduces overhead, compared with asynchronous transmission, by eliminating the need to send individual start and stop bits for each character transmitted.

## **SYSTEMS PROGRAMS**

Computer programs that provide a particular service to the user; for example, compilers, assemblers, operating systems, soft-merge programs, linkage editor programs, graphic support programs, etc.

## **T**

### **TERMINAL**

(1) An I/O peripheral device which is on-line to the computer, but which is in a remote location: another room, another city, or another country. (2) A point at which information can enter or leave a communication network.

### **TRACKS**

A series of concentric rings on a disk or diskette. Data can be written to or read from the tracks by the read-write head.

## **U**

### **UPDATE**

To incorporate into a master file the changes required to reflect transactions or other events.

### **USER GROUP**

A group of computer users that share knowledge they have gained and programs they have developed on a computer or class of computers of a specific manufacturer.

### **UTILITY ROUTINES**

Software used to perform some frequently required process in the operation of a computer system.

## **V**

### **VALIDATION**

The examination of data for correctness against certain criteria, such as format, ranges, check digits, equivalent entries on a master file.

**VARIABLE**

A quantity that can assume any of a given set of values.

**VERIFY**

(1) To determine whether a data processing operation has been accomplished accurately; e.g., to check the results of keypunching. (2) To check data validity.

**W**

**WORD**

A group of bits, or bytes considered as an entity and capable of being stored in one storage location.

**WORD LENGTH**

The number of bits, or bytes in a word.

**WRITE**

(1) The process of transferring information from the computer to an output medium. (2) To copy data, usually from internal storage to auxiliary storage devices.

**WRITE-INHIBIT TAB**

Opaque tape used to cover the write-enable notch on diskettes to prevent writing on the disks.

**WRITE ENABLE NOTCH**

A small notch located on an edge of most diskettes. It permits data to be recorded on that diskette.

# Index

## Adding

- alpha controller board 3-12
- color graphics display 3-11, 3-13
- communication devices 3-23
- expansion boards 3-20
- external displays 3-26
- fixed disk drive 3-32
- fixed disk drive controller 3-36
- flexible disk drive 3-28
- graphics controller board 3-13
- main processor board 3-3
- memory expansion chips 3-17
- monochrome display 3-9, 3-12
- numeric coprocessor 3-22
- printer 3-24, 3-25

## Address registers 1-11

ALGOL 1-18

Arithmetic and logic unit (ALU) 1-10

ASCII 1-19, 1-21

Assemblers 1-2, 1-15, 1-17

BASIC 1-1, 1-2, 1-12, 1-16, 1-17, 1-18, 2-8

Binary 1-19, 1-20

BIOS, Connections table B-4

Bit 1-19

Boot routine 1-12, 2-11

Buying disks 1-22

Buying software 2-11

Byte 1-11

## Cable

connection 2-3, 2-4, 2-5

feature cable attachment 3-7



- fixed disk drive 3-35
- flexible disk drive 3-30, 3-31
- option cable attachment 3-8
- shielded 3-1
- terminating resistor pack 3-30
- video display 3-13, 3-15, 3-27

Cabinet disassembly 3-1

Central processing unit (CPU) 1-10, 1-11

COBOL 1-18

## Code

- ASCII 1-19, 1-21
- EBCDIC 1-20

Codes, types 1-15, 1-19

Color graphics adapter board 3-11

Communication devices 1-9, 1-10

Compilers 1-18

Connecting your computer 2-3, 2-4

Controller board data table B-3

Cursor 2-9, 2-16

Cursor keys 2-16, 2-17

Data files 1-14, 1-16

Density, disk 1-24

Diagnostic software 1-1, 4-7

Diagnostics 1-1, 4-7

Disassembly of cabinet 3-1

Diskette (see disk)

Disk

- adding on 3-28, 3-32
- capacity of 1-24
- care of 1-22
- formatting 1-24
- labels 1-23
- sectors 1-24
- tracks 1-23
- types of 1-22

## Disk drive

- fixed 3-32
- flexible 3-28

## Display

- care of 2-20
- hook-up 3-9, 3-11

EBCDIC 1-20  
Editors 1-17  
Expansion boards 3-20  
Expansion slot connections table B-3

Files, data 1-14, 1-16  
Fixed disks 1-21, 3-32  
Flexible disks 1-22, 3-28  
FORTRAN 1-18  
Function keys 2-12  
Function of keys 2-12

GW-BASIC 1-1, 1-2, 1-18, 2-8

## Hardware

- definition 1-10
- interrupts B-4
- keyboard 2-7, 2-11, 2-12
- models 2-5
- options 3-1
- technical data for B-1

High-level languages 1-18

## How to

- connect printer 3-25
- expand memory 3-19
- insert boards 3-5
- install options 3-1
- install your computer 2-3
- power-on 2-9
- select a site 2-1
- set switches C-1
- take care of your computer 2-1, 2-19, 4-1
- test 2-9, 4-7, 4-9
- unpack 2-2
- use keyboard 2-11

Installing options 3-1  
Installing software 2-11  
Installing your computer 2-3  
Interrupt levels table B-4



**Keyboard**

- connection 2-3
- data table A-1
- features 2-11
- function summary A-3
- illustrated 2-13, A-2
- key descriptions 2-12
- using 2-12

Keys, described 2-12

Labeling disks 1-23

Linkers 1-18

Machine language code 1-15

Macro 1-17

**Memory**

- address 1-11
- definition 1-11
- expanded 3-16, 3-17
- external 1-12
- internal 1-11
- loss of 1-13
- recording data in 1-11, 1-13
- size 1-11, 1-21, 1-24, 2-7, 3-17

Microprocessor 1-6, 1-7, 2-7

Model numbers, list of 2-5

Monochrome adapter board 3-9

Monochrome display 2-7

Moving your computer 4-2

NCR-DOS 1-1, 1-2, 2-8

Numeric keys 2-17

Pascal 1-18

Pin assignments, tables B-3, B-6

Pixels 3-11

PL/1 1-18

Preparing for your computer 2-1

Preventing problems 2-1, 2-18

**Problems**

- identifying 4-8
- preventing 2-1, 2-18
- radio interference 4-6

**Programs**

- application 2-11
- definition of 1-18
- start-up 2-11

Random access memory (RAM) 1-11, 2-7

Read only memory (ROM) 1-11, 2-7

Relocating your computer 4-2

Removing cover 3-1

Run all tests 4-23, 4-28

Running application software 2-11

Running diagnostics 4-9

Selecting a site 2-1

Setting switches C-1

**Software**

- application 2-8, 2-11
- buying 2-8, 2-11
- definition of 1-14
- diagnostic 4-3, 4-7
- installing 2-11
- optional 2-11
- program development 2-8
- source language 1-15
- sources 2-11
- system 2-8

Source code 1-15, 1-16, 1-18, 1-20

Specifications, technical B-1

Taking care of your computer 2-1, 2-18

Technical data B-1

**Testing**

- CPU and main processor board 2-9
- communication port 4-22
- controllers 4-11
- diagnostics 4-7
- display, color 4-17
- display, monochrome 4-16
- fixed disk drive and controller 4-15
- flexible disk drive 4-14
- keyboard 4-13
- light pen 4-21
- memory 2-9, 4-10

peripherals 4-21  
power-on 2-9  
printer 4-21  
tape drive 4-22  
Tests, run all 4-28  
Troubleshooting 4-7  
Turning on your computer 2-9  
Typewriter keys 2-15

Unpacking your computer 2-2  
Utility programs 4-3, 4-23

Write-protect notch 1-22



# READER'S COMMENTS

We Welcome Your Critical Evaluations Of Our Manuals. Please Use The Space Provided Below. Then Fold The Form As Indicated . . . Mail To Us . . . No Postage Required.

Do You Have Any General Comments Regarding The Accuracy, Organization, Completeness, And Usability Of This Manual?

Manual Name \_\_\_\_\_

Comments \_\_\_\_\_

\_\_\_\_\_

\_\_\_\_\_

Please Indicate Your Opinion Of This Manual.

|                                       | CLARITY | ACCURACY | ORGANIZA-<br>TION | COMPLETE-<br>NESS | USABILITY |
|---------------------------------------|---------|----------|-------------------|-------------------|-----------|
| Excellent (Needs No Improvement)      | _____   | _____    | _____             | _____             | _____     |
| Good (Could Use Minor Improvement)    | _____   | _____    | _____             | _____             | _____     |
| Fair (Should Have Major Improvements) | _____   | _____    | _____             | _____             | _____     |
| Poor (Should Be Completely Changed)   | _____   | _____    | _____             | _____             | _____     |

Did You Find Any Errors In The Manual? (Please Include All Of The Indicated Information)

Tab Name: \_\_\_\_\_

Chapter Number: \_\_\_\_\_ Page No: \_\_\_\_\_

Description: \_\_\_\_\_

\_\_\_\_\_

\_\_\_\_\_

\_\_\_\_\_

Do You Have Any Recommendations For Ways In Which This Manual Can Be Improved?

\_\_\_\_\_

\_\_\_\_\_

\_\_\_\_\_

\_\_\_\_\_

Your Name \_\_\_\_\_

Company \_\_\_\_\_

Address: \_\_\_\_\_

\_\_\_\_\_

\_\_\_\_\_

Date: \_\_\_\_\_ Tele. No. \_\_\_\_\_

Position \_\_\_\_\_

NOTE: This Is Not An Order Form. Orders For Additional Publications Must Be Placed Through Your NCR Office.  
Thanks

cut

fold



NO POSTAGE  
NECESSARY  
IF MAILED  
IN THE  
UNITED STATES

**BUSINESS REPLY CARD**  
FIRST CLASS PERMIT NO. 2 LIBERTY, SC

POSTAGE WILL BE PAID BY ADDRESSEE

**NCR CORPORATION**  
**Personal Computer Division**  
**Quality Assurance Manager**  
**1150 Anderson Drive**  
**Liberty, SC 29657**





NCR Corporation  
Dayton, Ohio 45479

150-0000952